

NO

CS007-UM

CSD3 Series

Servo Drive

Manual





1 :

1.1	2
1.2	3
1.2.1	3
1.2.2	3
1.2.3	4
1.2.4	4
1.3	5
1.3.1	5
1.3.2	6
1.3.3	()	7
1.3.4	()	7
1.3.5	8
1.3.6	8
1.3.7	10
1.4	()	11
1.4.1 SERCOS	13
1.4.2 DeviceNet	14
1.4.3 RS485	15
1.4.4	16

2 :

2.1	18
2.1.1	18
2.1.2	20

3 :

3.1	24
3.2	25
3.2.1	25
3.2.2	27
3.2.3	28
3.3	(CN1)	29
3.3.1	29
3.3.2 (CN1)	30
3.4	(CN1)	32

3.4.1	()	32
3.4.2	()	33
3.5	(CN1)	34
3.5.1	()	34
3.5.2	()	35
3.6	(CN1)	36
3.6.1		36
3.6.2		37
3.6.3		37
3.6.4		38
3.7	(CN1)	39
3.8	(CN2)	41
3.8.1	(CN2)	41
3.8.2	(CN2)	42
3.8.3		43
3.9	(CN5)	46
3.10		47
3.10.1		47
3.10.2		48
3.10.3		49
3.10.4		52
3.10.5		53

4 : ,

4.1		56
4.1.1	-ON	56
4.1.2		58
4.2		59
4.2.1		59
4.2.2		60
4.2.3		60
4.2.4		61
4.2.5		62
4.2.6		63
4.2.7		64
4.3		65
4.3.1		65
4.3.2		66
4.3.3		69
4.3.4		72

4.4	74
4.4.1	74
4.4.2	74
4.4.3	76
5	:	
5.1	78
5.1.1	?	78
5.1.2	79
5.1.3	80
5.1.4	81
5.1.5	82
5.1.6	83
5.2	84
5.2.1	84
5.2.2	85
5.2.3	86
5.2.4	88
5.2.5	89
5.2.6	90
5.2.7	(PCLR)	96
5.2.8	</INHIB>	97
5.2.9	</P-COM>, </NEAR>	98
5.2.10	100
5.2.11	Timing diagram	100
5.3	101
5.3.1	101
5.3.2	102
5.3.3	103
5.3.4	</Z-CLP>	104
5.3.5	</V-COM>	105
5.3.6	</TG-ON>	106
5.3.7	</V-LMT>	107
5.4	108
5.4.1	108
5.4.2	109
5.4.3	110
5.4.4	<T-LMT>	112
5.5	115
5.5.1	115

5.5.2	116
5.5.3	117
5.6	</C-SEL>	119

6	:
----------	----------

6.1	122
6.1.1	122
6.1.2	(Gain)	123
6.1.3	124
6.2	125
6.3	127
6.3.1	127
6.3.2	-	127
6.3.3	-	128
6.4	129
6.4.1	129
6.4.2	130
6.5	(, ,)	132
6.5.1	132
6.5.2	134
6.5.3	136
6.6	Tip	138
6.6.1	(Feedforward)	138
6.6.2	(Bias)	139
6.6.3	P/PI	140
6.6.4	144
6.6.5	</G-SEL>	146

7	:
----------	----------

7.1	149
7.1.1	149
7.1.2	(8.2.2)	149
7.1.3	<P-OT>, <N-OT>	149
7.1.4	(Dynamic Brake)	151
7.2	152
7.3	156
7.4	157
7.4.1	157
7.4.2	158
7.4.3	159

7.5	165
7.6	167
7.7	169
7.7.1	169
7.7.2	170
7.8	172
7.9	174
7.9.1	?	174
7.9.2	175
7.9.3	175
7.9.4	177
7.9.5	178
7.10	181
7.10.1	181
7.10.2	(run-00)	182
7.10.3	- (run-01)	183
7.10.4	(run-02)	184
7.10.5	(run-03)	185
7.10.6	(run-04)	186
7.10.7	(run-05)	187
7.10.8	(run-06)	188
7.10.9	(run-07)	189
7.10.10	(run-08)	190
7.10.11	(run-09)	191
7.10.12	(run-10)	192
7.10.13	(run-11)	192

8	:	
----------	----------	--

8.1	198
8.1.1	198
8.1.2	198
8.1.3	199
8.1.4	(7.9.3)	199
8.2	200
8.2.1	200
8.2.2	202
8.2.3	A/S	209



A 1	214
A 1.1	0	214
A 1.2	1	220
A 1.3	2	225
A 1.4	3	230
A 1.5	4	234
A 1.6	5	237
A 1.7	244
A 1.8	245
A2	249
A.2. 1	249
A.2. 2	250
A3	253
A.3. 1 CSM	253
A.3. 2 CSMT	(17bi t)257	
A.3. 3 CSME	(17bi t)	260
A.3. 4 CSMV	(17bi t)	262
A.3. 5 CSMQ	264
A.3. 6 CSMZ	266
A.3. 7 CSMD	268
A.3. 8 CSMF	271
A.3. 9 CSMH	274
A.3. 10 CSMS	277
A.3. 11 CSMK	280
A4	283
A.4. 1 CSM	284
A.4. 2 CSM286	
A.4. 3 CSMT	(17bi t)	289
A.4. 4 CSMZ	291
A.4. 5 CSME	(17bi t)	292
A.4. 6 CSMQ	293
A.4. 7 CSMV	(17bi t)	294
A.4. 8 CSMD/F/HW/S	295
A5	300
A.5. 1	3	300
A.5. 2	303
A.5. 3 I/O	308
A.5. 4	309

	A.5. 5	309
	A.5. 6	310
A.6	313
	A.6. 1 ROLL	313
	A.6. 2 TIMING BELT3	16
	A.6. 3 BALL SCREW	318
	A.6. 4 BALL SCREW	320
	A.6. 5 RACK & PINION	322
	A.6. 6	324
A.7	312
A.8	331

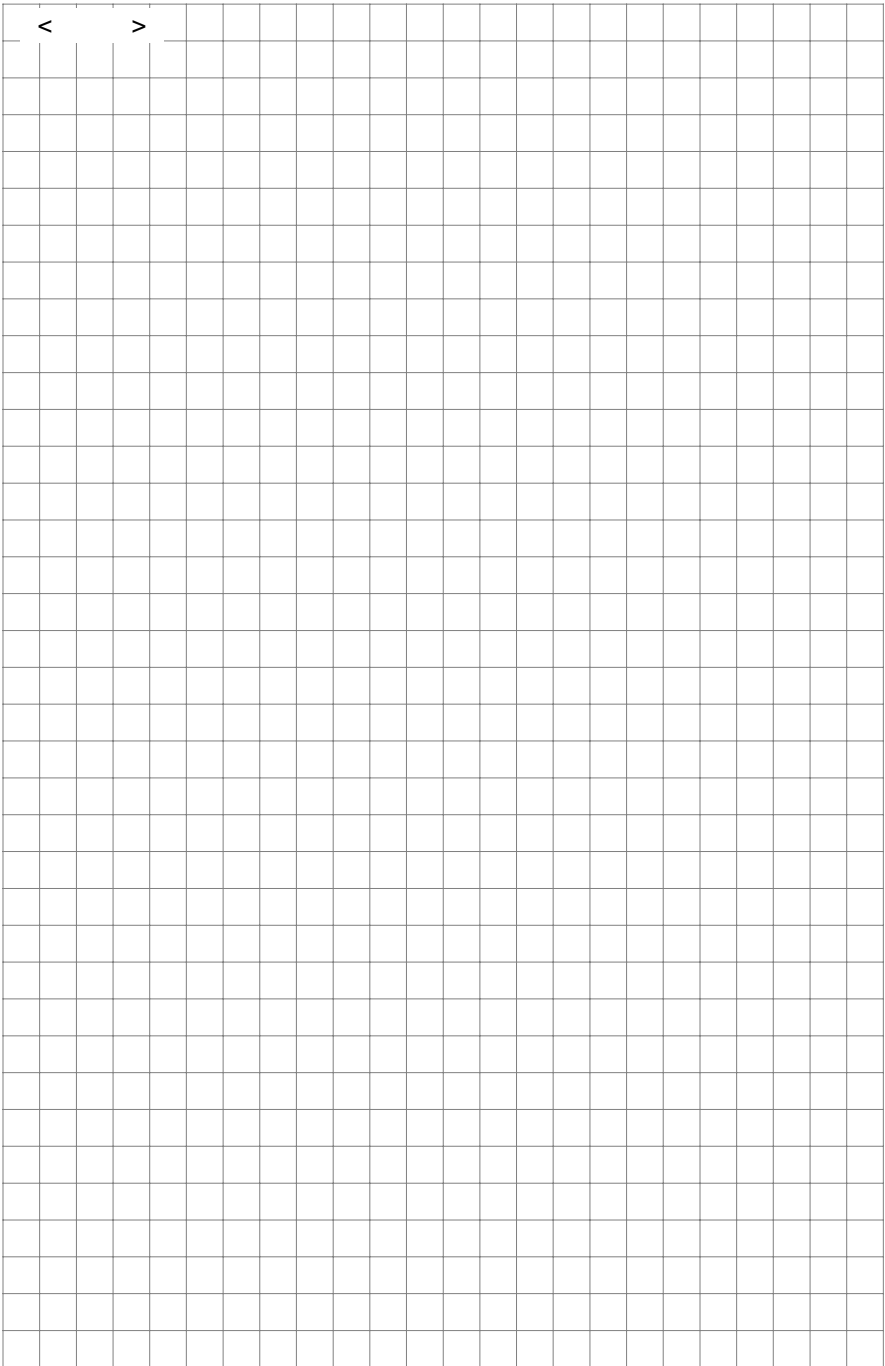

FARA CSD3 SERVO DRIVE

1.1	2
1.2	3
1.2.1	3
1.2.2	3
1.2.3	4
1.2.4	4
1.3	5
1.3.1	5
1.3.2	6
1.3.3	()	7
1.3.4	()	7
1.3.5	8
1.3.6	8
1.3.7	10
1.4	()	11
1.4.1 SERCOS	13
1.4.2 DeviceNet	14
1.4.3 RS485	15
1.4.4	16

1.



가 가

2.



가

3.



가

4.



가



가



1.2

1.2.1

▶ : CSD3 SERVO DRIVE
 ▶ :
 ▶ :
 ▶ :
 ▶ :
 ▶ : 가

1.2.2

1. Active Low ' / '



2. 가

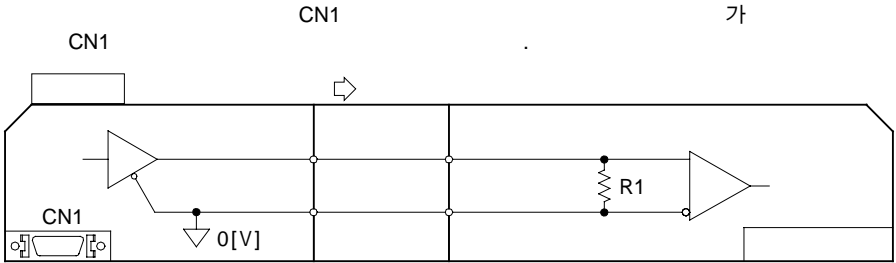

3. 가

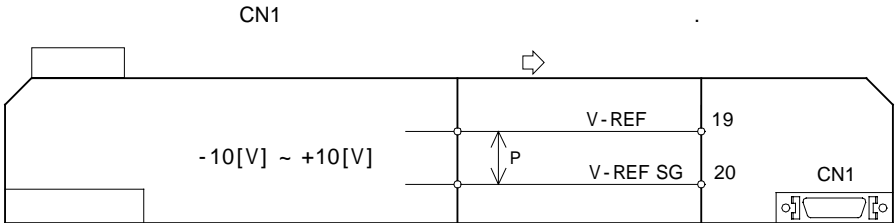

4.

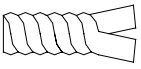

	<p>▶ 가</p> <p>▶ A B</p>

5.

		▶ 가

6.

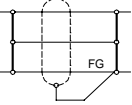
(Shield)

		▶ 가

1.2.3

1			2
		↓	
3			4
		↓	
5			6
		↓	
7	가		8
		↓	
9			10
		↓	
11			12
		↓	

1.2.4

가

1.3

1.3.1

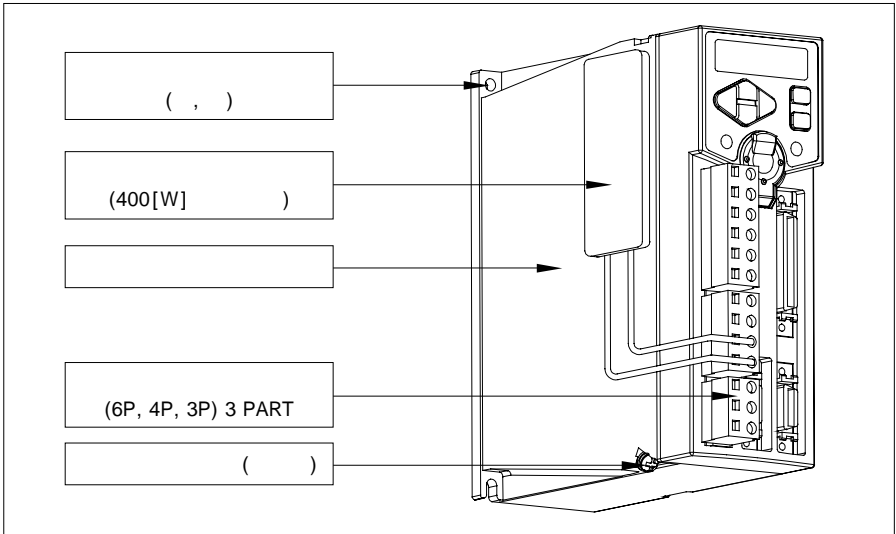
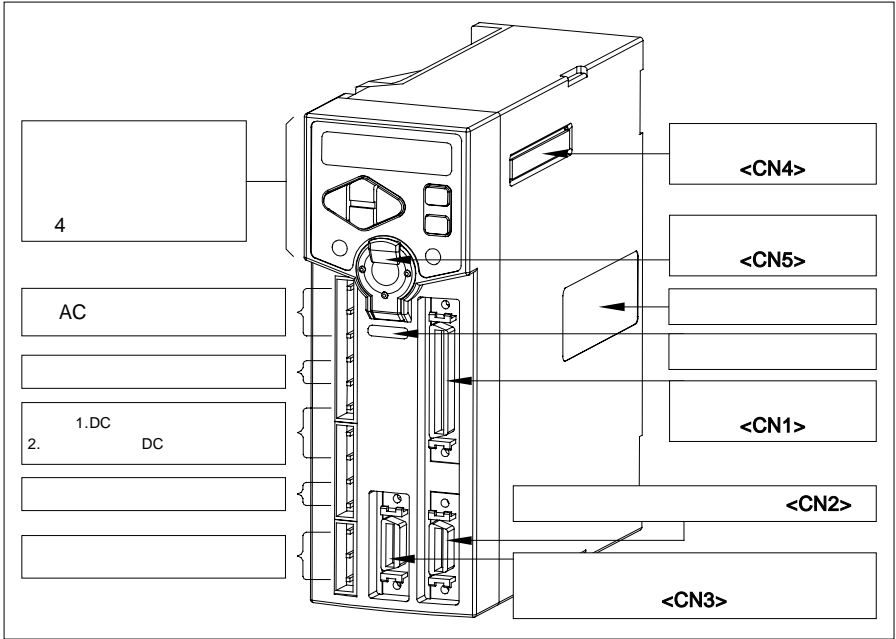

1.3.2



FARA SERVO DRIVE DS3-Series

가

가

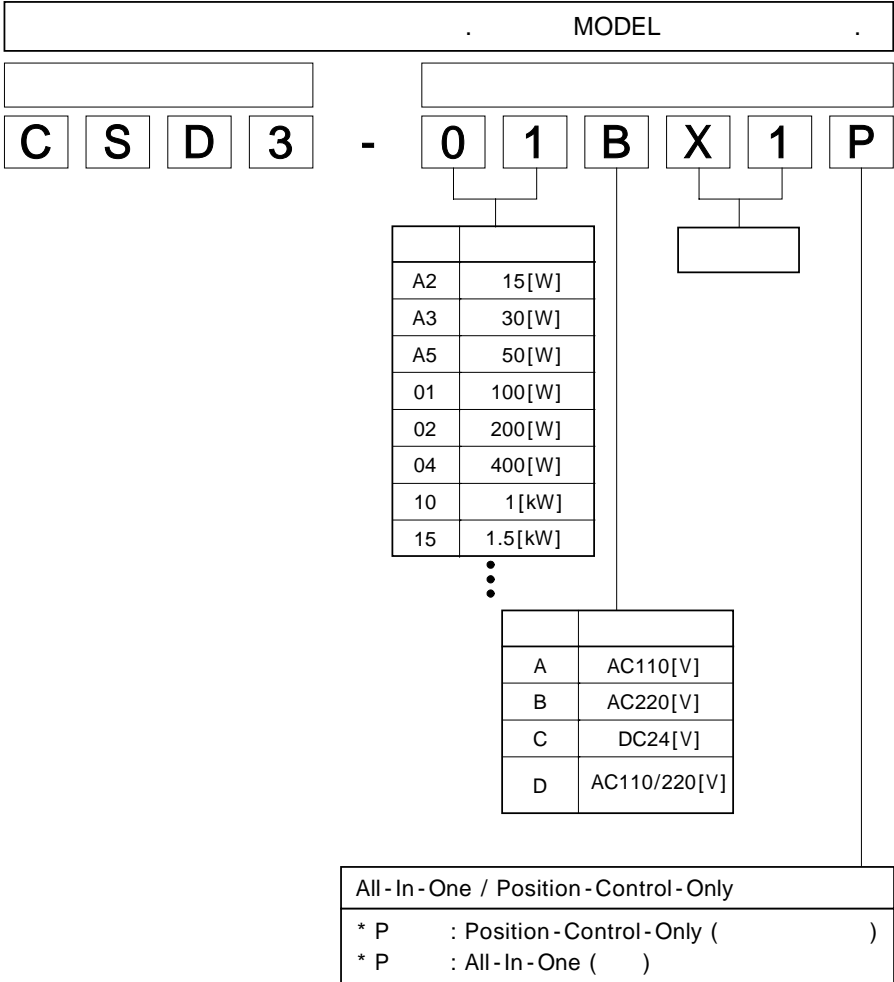

1.3.3 ()

2

1. All-In-One Type : ()



2. Position-Control-Only Type :



'Position-Only'

()					
All-In-One Type			Position-Control-Only Type		
RED	7-	LED	GREEN	7-	LED
All-In-One			Position-Only		

3.



DS3-Series

2가

1.3.4 ()

()

1	CSD3-A3BX1(P)	30[W]	15[W] ~ 30[W]
2	CSD3-A5BX1(P)	50[W]	50[W]
3	CSD3-01BX1(P)	100[W]	100[W]
4	CSD3-02BX1(P)	200[W]	200[W]
5	CSD3-04BX1(P)	400[W]	300[W] ~ 400[W]
6	CSD3-10BX1(P)	1[kW]	500[W] ~ 1[kW]
7	CSD3-15BX1(P)	1.5[kW]	1.2[kW] ~ 1.5[kW]

1.3.5

▶ 가
▶

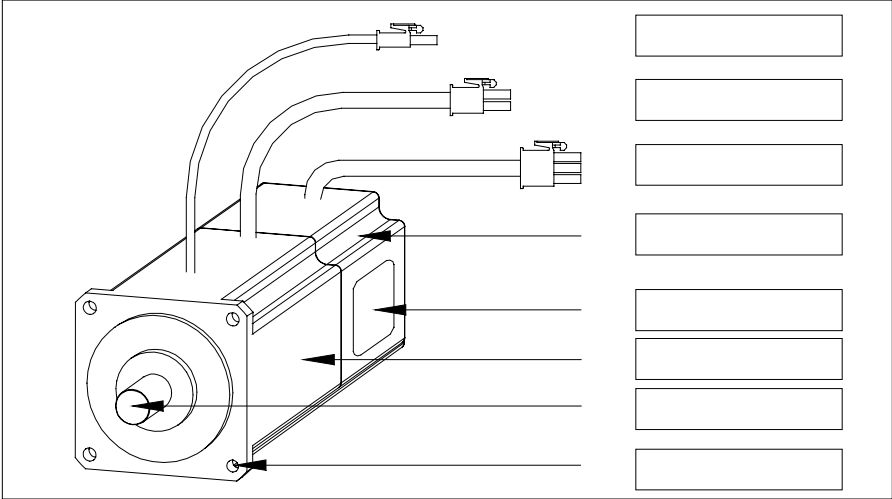

1.3.6

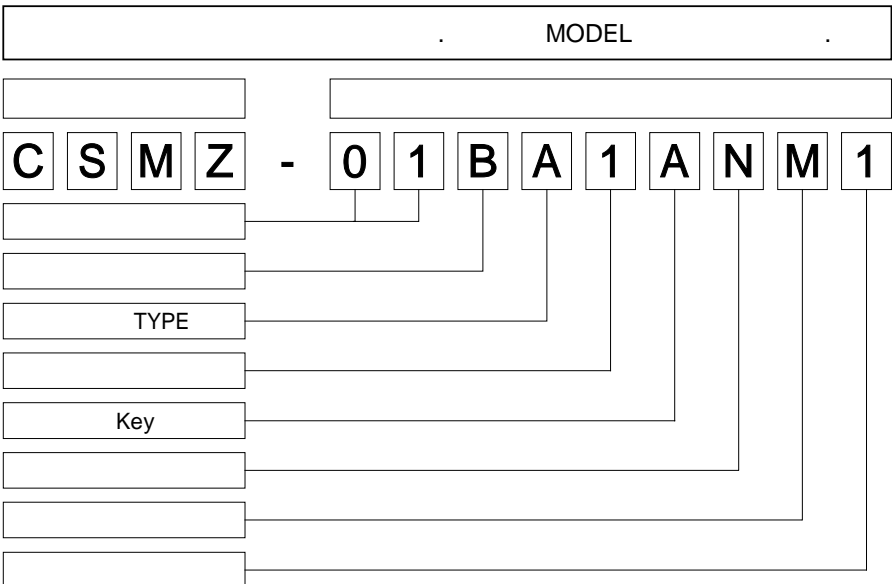

MODEL

CSM	CSMP	CSMQ	CSMZ	CSMS	CSMD	CSMH	CSMF	CSMK	CSMT	CSMR	CSME	CSMW

A2	A3	A5	01	02	04	~	10	~	50	
15[W]	30[W]	50[[W]	100[W]	200[W]	400[W]	~	1[kW]	~	5[kW]	

A		B		C		D	
AC 110[V]		AC 220[V]		DC 24[V]		AC 110/220[V]	

Type							
: CSMT, CSMR, CSME, CSMW							
	/1	TYPE			/1	TYPE	
Q	131072			R	131072	Inc.	

: CSM, CSMP			
	/1	TYPE	
S	2048	15	Inc.
B	2048	9	Inc.
A	2048		
D	2500	15	Inc.
C	2000	15	Inc.
K	5000	15	Inc.

: CSMQ/Z/S/D/H/F/K			
	/1	TYPE	
A	2500	11	Inc.
B	2500	15	Inc.
D	1000	15	Inc.
H	2048	Compact	
J	2048	Full	
M	10000	15	Inc.

Key	
A	B
Key	Key

N	B	S	T
		Oil Seal	Oil seal &

1	2	3	4	5	6
(Coupling)	2 Slice (Set screw)	Key	Tapper		Harmonic Drive



1.3.7

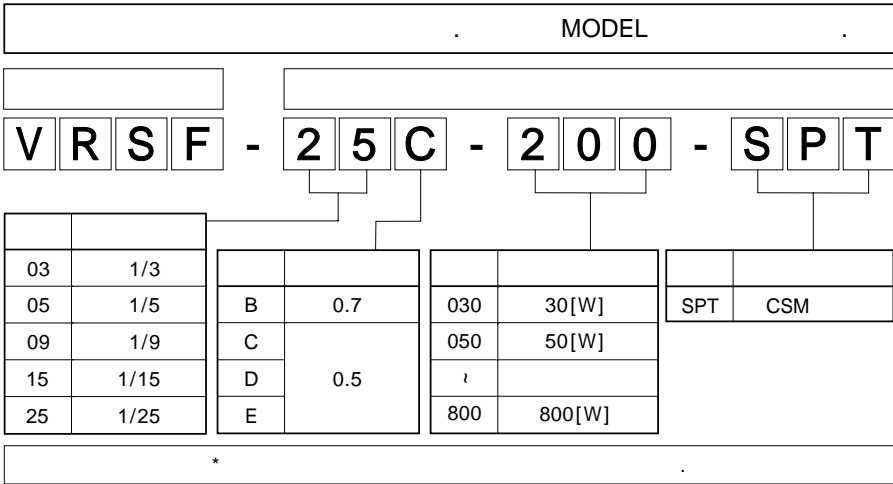

■ CSM

VRSF-					
	1/3	1/5	1/9	1/15	1/25
	03B - 50 - SPT	05B - 50 - SPT	9B - 50 - SPT	15B - 50 - SPT	25B - 50 - SPT
	03B - 100 - SPT	05B - 100 - SPT	9B - 100 - SPT	15B - 100 - SPT	25C - 100 - SPT
	03B - 200 - SPT	05B - 200 - SPT	9C - 200 - SPT	15C - 200 - SPT	25C - 200 - SPT
	03B - 400 - SPT	05C - 400 - SPT	9C - 400 - SPT	15C - 400 - SPT	25D - 400 - SPT
	03C - 600 - SPT	05C - 600 - SPT	9B - 600 - SPT	15D - 600 - SPT	25E - 600 - SPT
	03C - 800 - SPT	05C - 800 - SPT	9B - 800 - SPT	15D - 800 - SPT	25E - 800 - SPT

► CSM

1.4 ()

(Network)

가 FA (Factory Automation)

가

- ▶ 가 (Option) CN4
- ▶ 가 SERCOS DeviceNet
- ▶ 2 가 RS485 가
- ▶ SERCOS , DeviceNet
- ▶ 5
- ▶

	SERCOS	DeviceNet
Command	(32Bit) (32Bit) (16Bit)	(16Bit) (16Bit) (16Bit)
Feedback	(32Bit) (32Bit) (16Bit)	(16Bit) (16Bit) (16Bit)
Baud rate [bps]	Dip 2M, 4M, 8M, 16M	Auto baud rate 125k, 250k, 500k
No. of slaves	8 Slaves/1 Master Total 256 Slaves	64 Slaves
Standard Mode	Standard Mode (0~6)	Standard Explicit Message (20, 22, 24, 70, 72, 74)
Physical layer	Fiber optic cable	5 Wire cable
Status	Send (O) / Receive (O)	Send (O) / Receive (O)
Error check	O	O



SERCOS

DS3

가

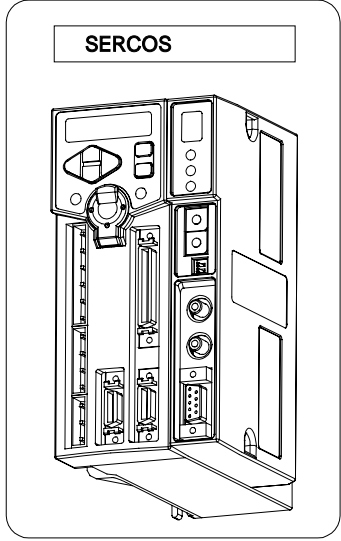
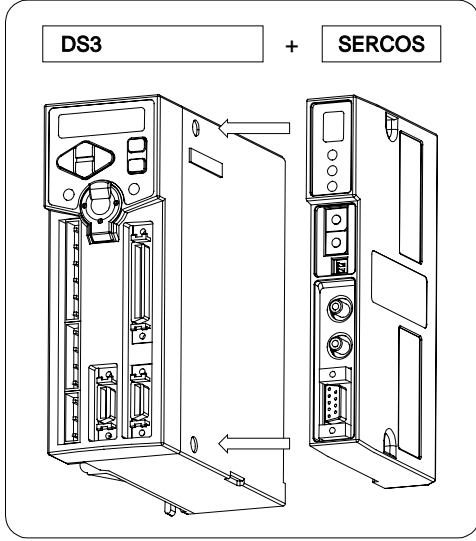

DeviceNet

DS3

가

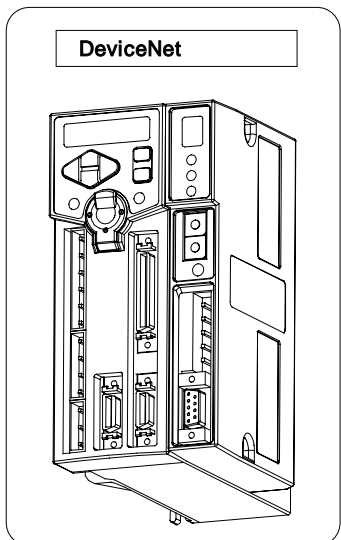
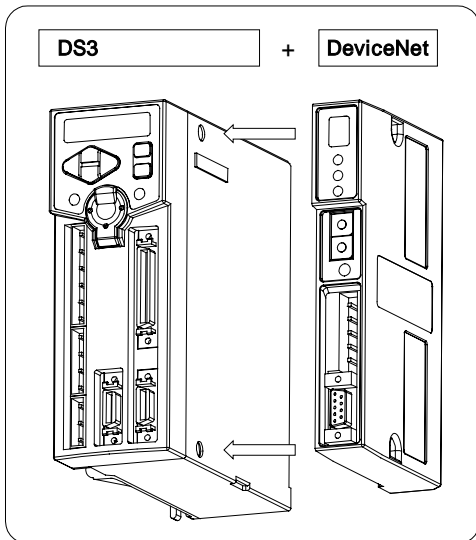

1.4.1 SERCOS

SERCOS

▶ SERCOS

▶ SERCOS

32

(Master) 1

8

256

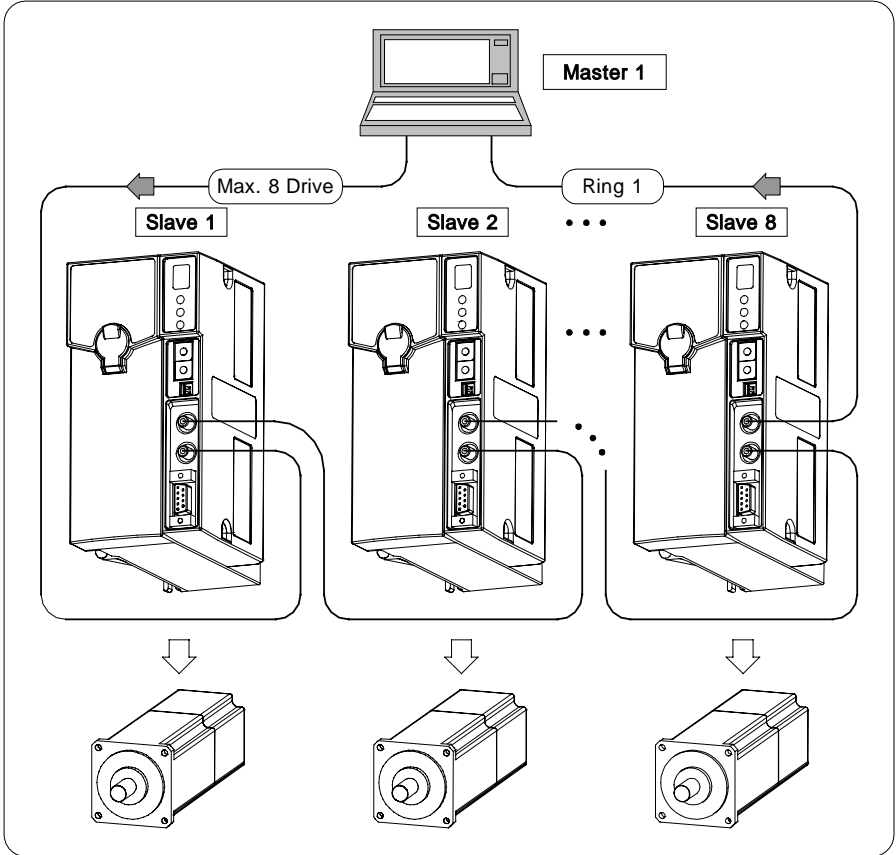

1.4.2 DeviceNet

DeviceNet

5

▶ DeviceNet

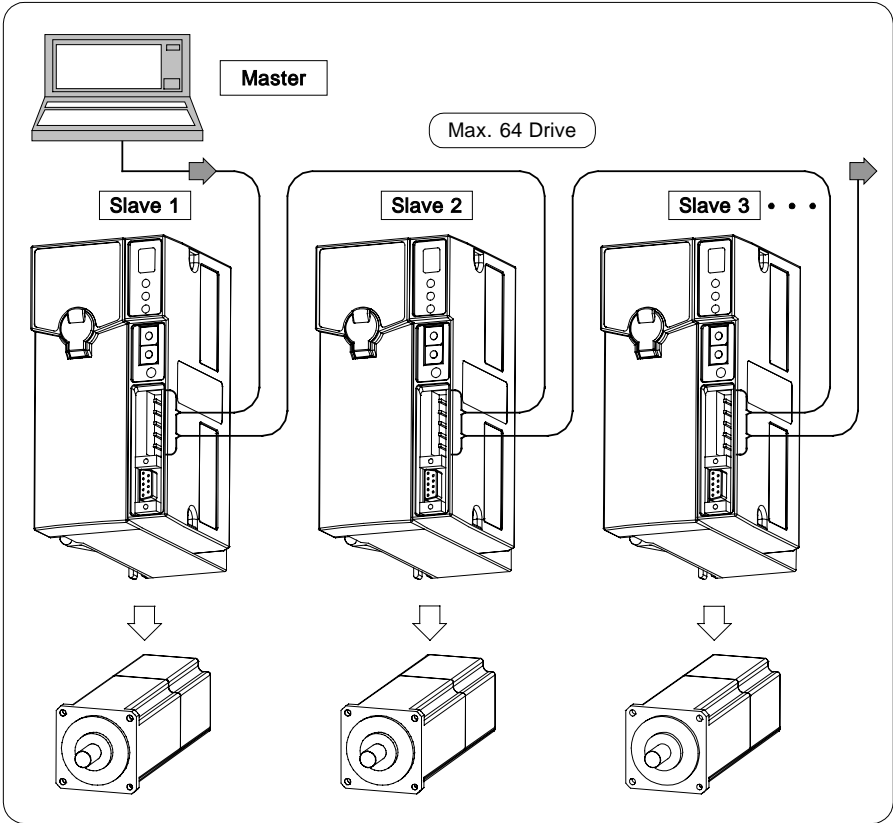

1.4.3 RS485

SERCOS, DeviceNet

RS485

▶ RS485

▶ RS485

CN3

▶ RS485

RS485

	RS485
Baud rate	57600[bps]
No. of slaves	32

▶ RS485

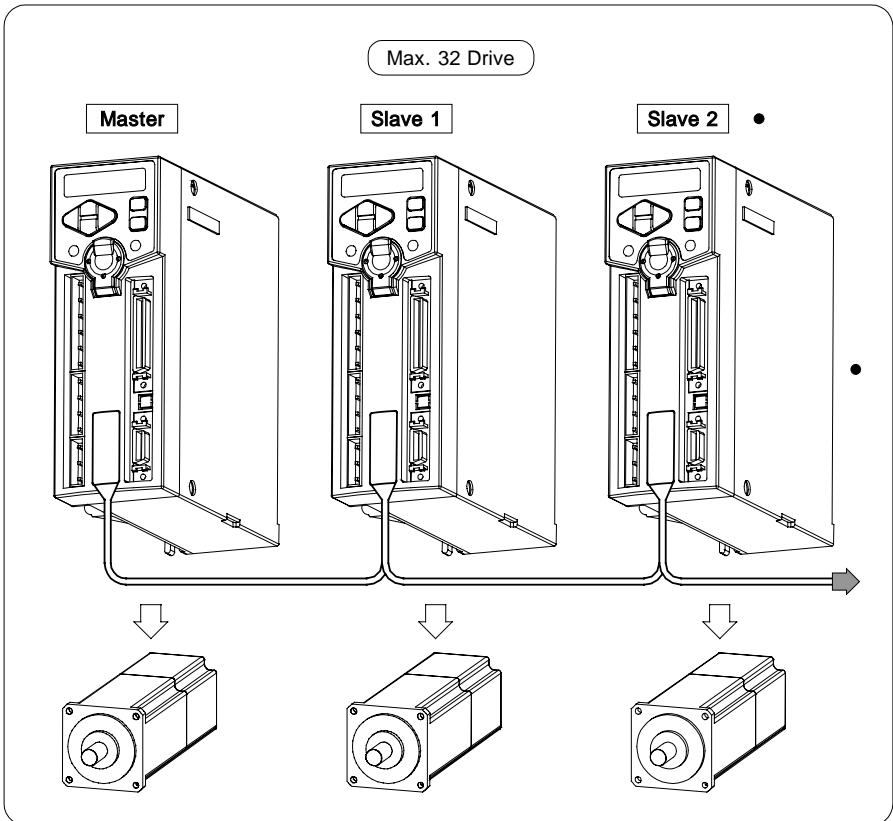

1.4.4

가

- ▶ Serial type Win CE 3.0 PDA
Graphic user interface program
- ▶ Graphic user interface
- ▶ Upload / Download
- ▶ (Oscilloscope)

가

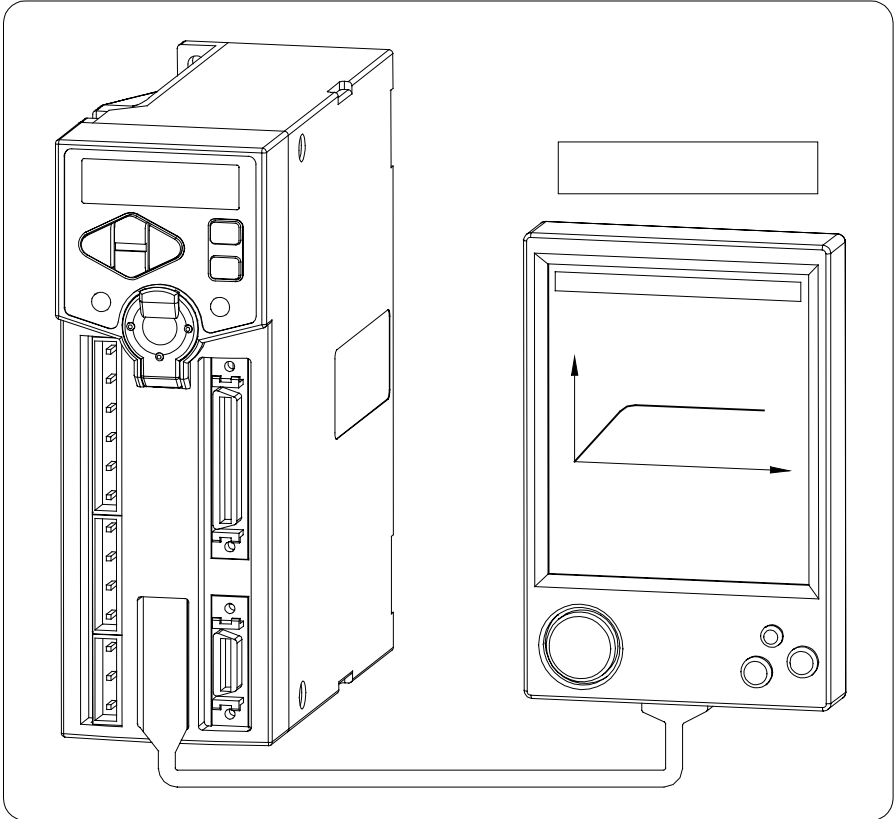

2 :

2.1	18
2.1.1	18
2.1.2	20

2.1

2.1.1

1.

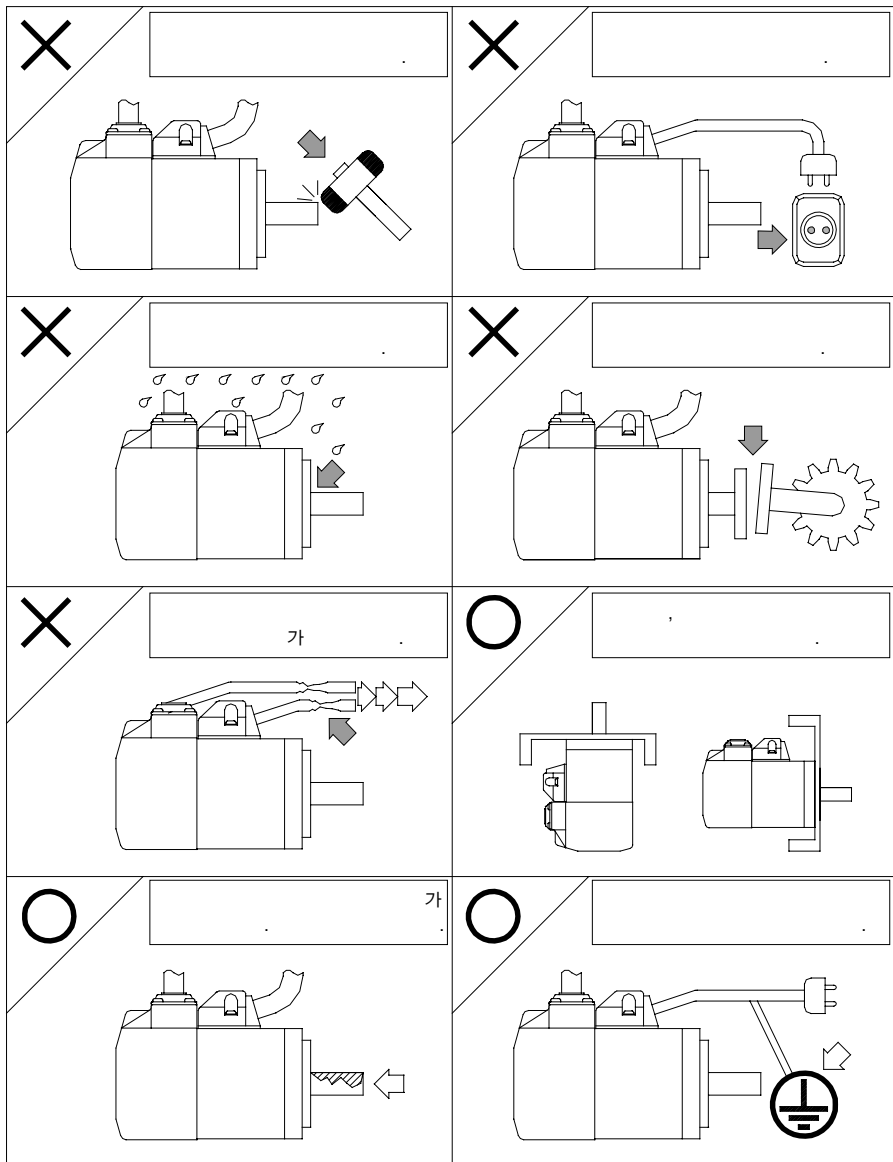

2.

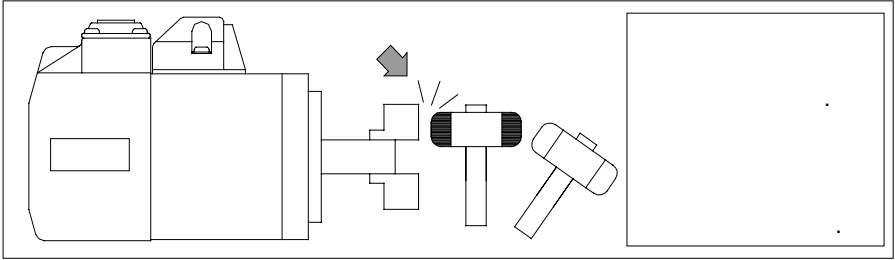

3.

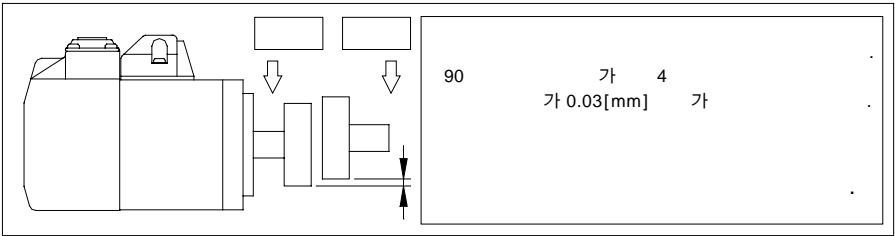

4.



가

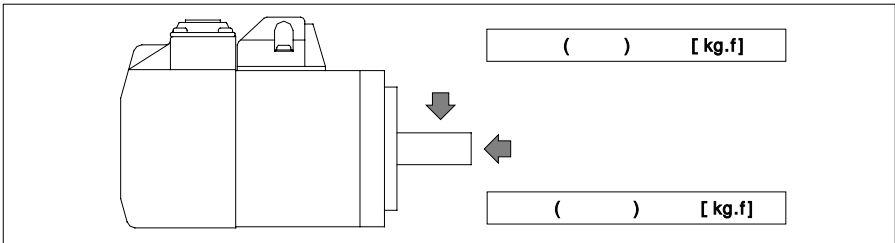

5.

	-20 ~ 60[°C]
	0 ~ 55[°C]
	90[%] RH ,
	, 가 , 가 가

2.1.2

1.



가

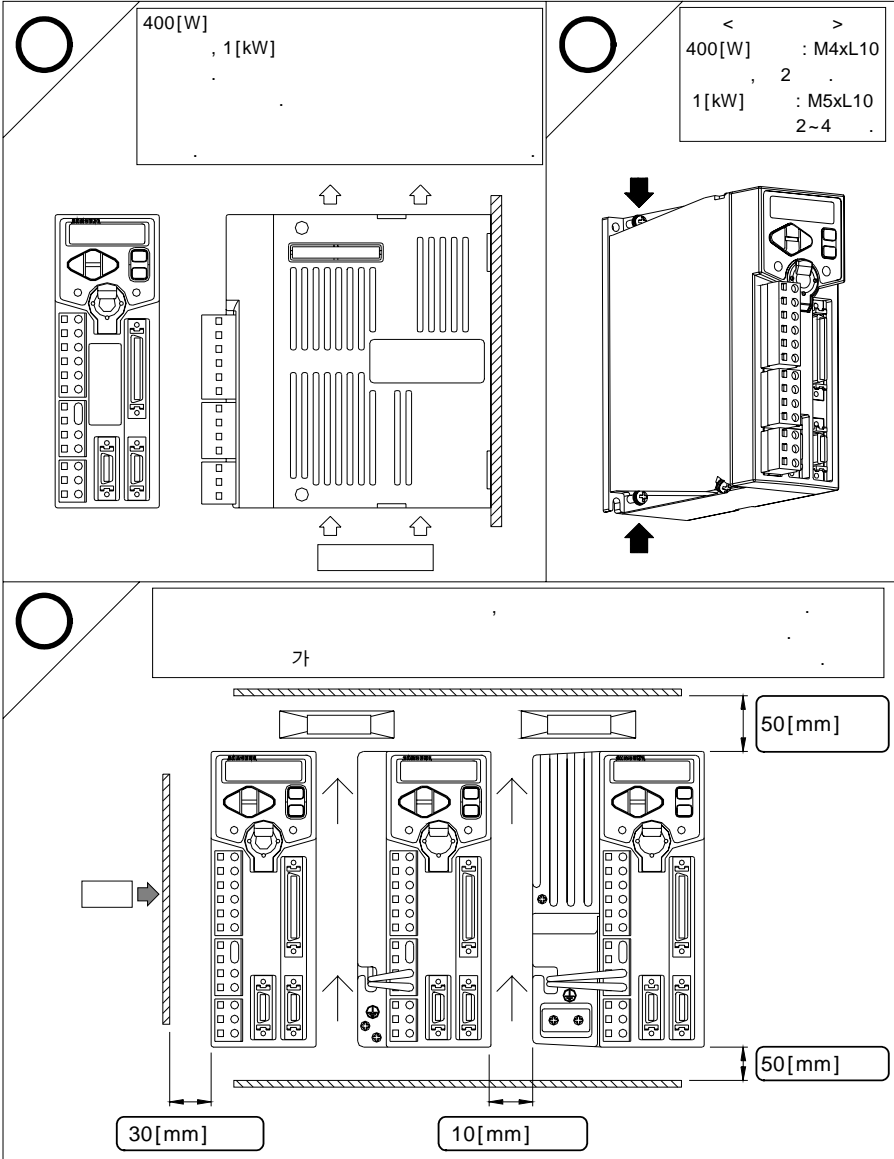

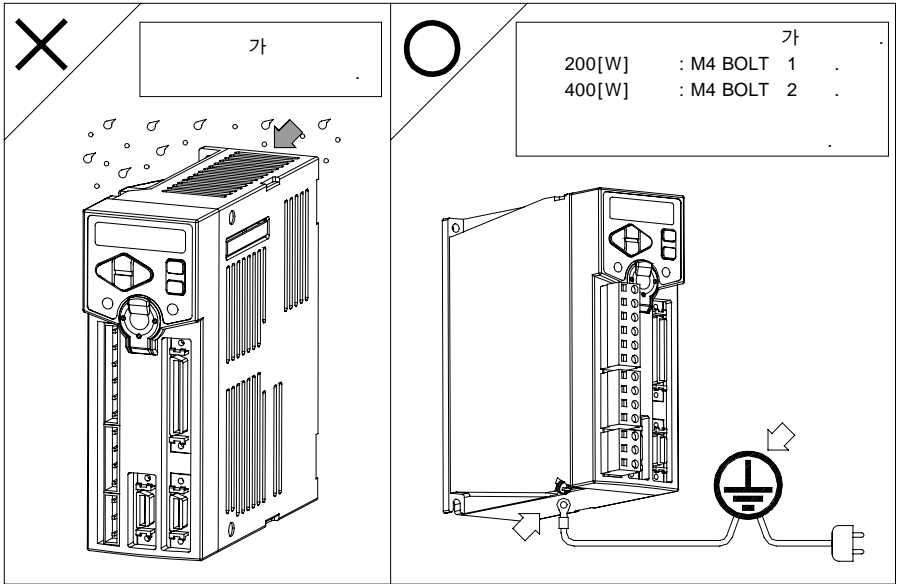

2.

	-20 ~ 80[°C]
	0 ~ 55[°C]
	90[%] RH
	0.5[g] (4.9[m/s ²])
	가
	: 0 ~ 45[°C]
	, , , 가 가

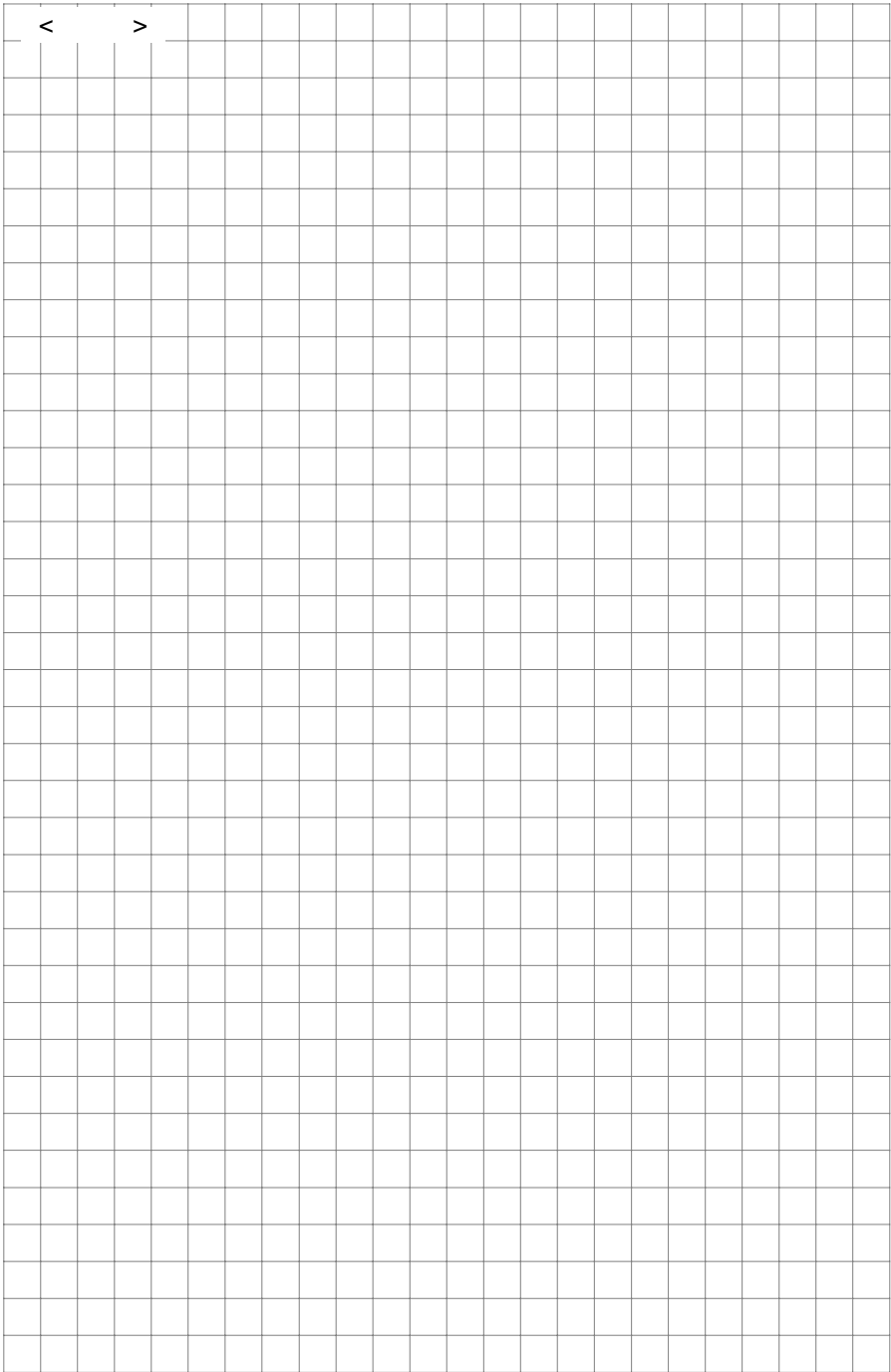

3.1	24
3.2	25
3.2.1	25
3.2.2	27
3.2.3	28
3.3	(CN1)	29
3.3.1	29
3.3.2 (CN1)	30
3.4 (CN1)	32
3.4.1	().....	32
3.4.2	().....	33
3.5 (CN1)	34
3.5.1	().....	34
3.5.2	().....	35
3.6 (CN1)	36
3.6.1	36
3.6.2	37
3.6.3	37
3.6.4	38
3.7 (CN1)	39
3.8	(CN2)	41
3.8.1 (CN2)	41
3.8.2 (CN2)	42
3.8.3	43
3.9	(CN5)	46
3.10	47
3.10.1	47
3.10.2	48
3.10.3	49
3.10.4	52
3.10.5	53

3.1

1.

	▶ 가 ▶ (Charge Lamp)가 ▶
---	------------------------------

	▶ ▶
---	--------

2.

▶

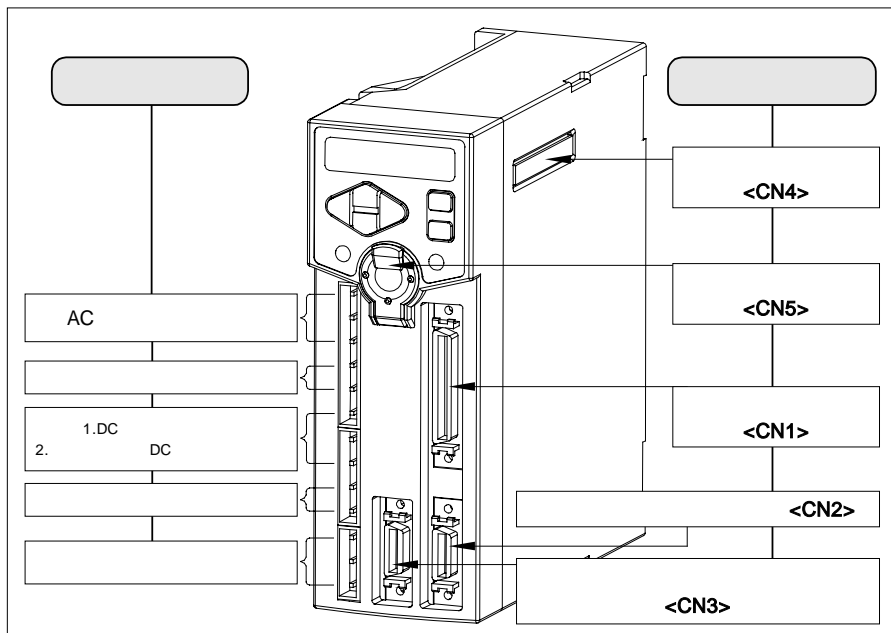

	▶ (CN1), (CN5) ▶ (CN2),
---	-------------------------------

3.2

3.2.1

가

	L1, L2, L3	AC
400[W]	200 ~ 230[V] (50/60 [Hz])	(L3)
400[W]	3	200 ~ 230[V] (50/60 [Hz])

	L1C, L2C	
		200 ~ 230[V] (50/60 [Hz])
▶	가	
▶	가	
▶	3.2.2	

	U, V, W	
▶		

	▶	(U, V, W)
	▶	

		()
▶		

	B1, B2	
200[W]	▶	가
400[W]	▶	
▶	7.4	

	N, P1, P2	DC	DC
▶	(L1, L2, L3) DC	AC	(N, P2)
▶	4.3.4		
▶	(L1, L2, L3)	AC	

▶	(L1, L2, L3) DC	AC	(P1, P2)
---	--------------------	----	----------

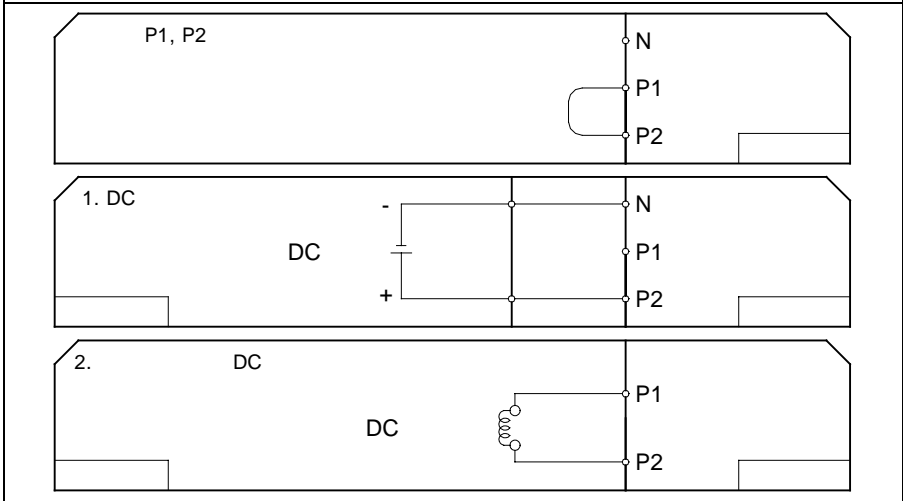

	▶	(L1, L2, L3) DC	AC	(N, P2)
	▶			

	▶	DC	4.2.4
--	---	----	-------

	▶	N, P1, P2	DC	DC (P1, P2)
--	---	-----------	----	----------------

3.2.2

AC

▶ () 400[W]
, L3

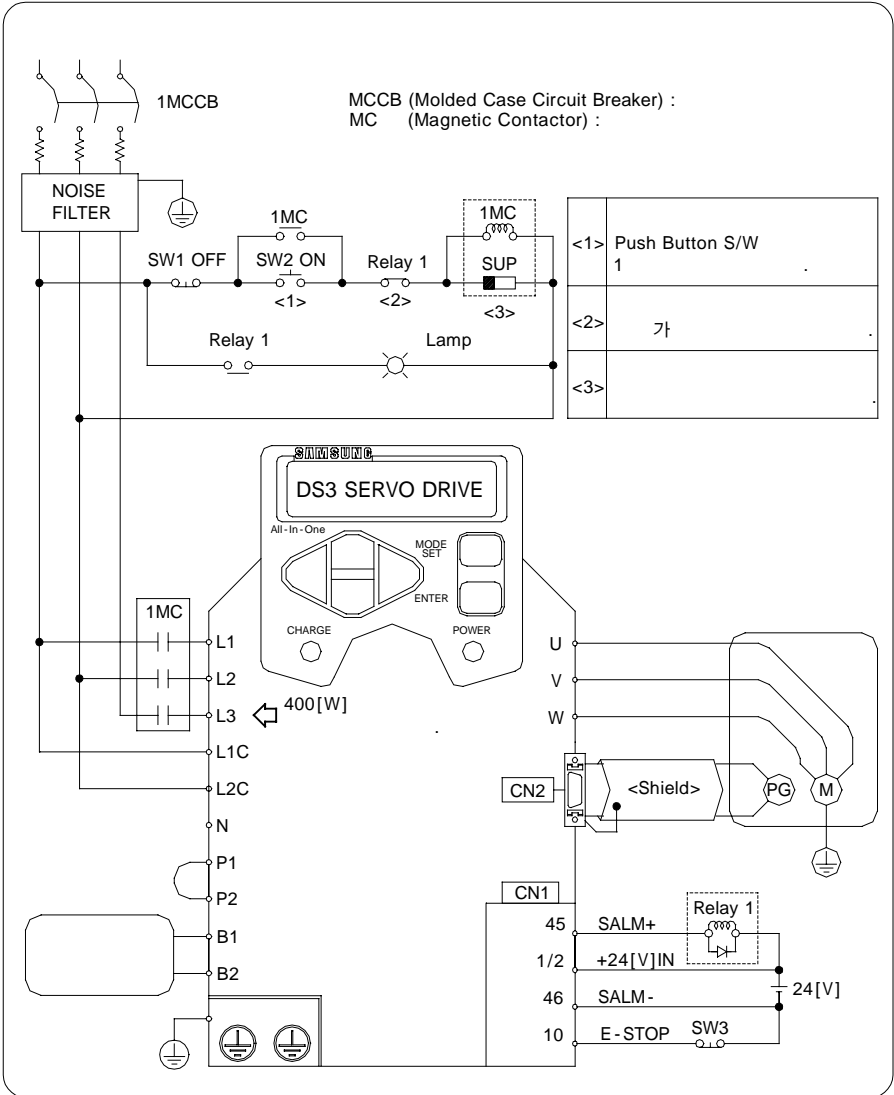

3.2.3



1 가

(8[mm]).

가 가

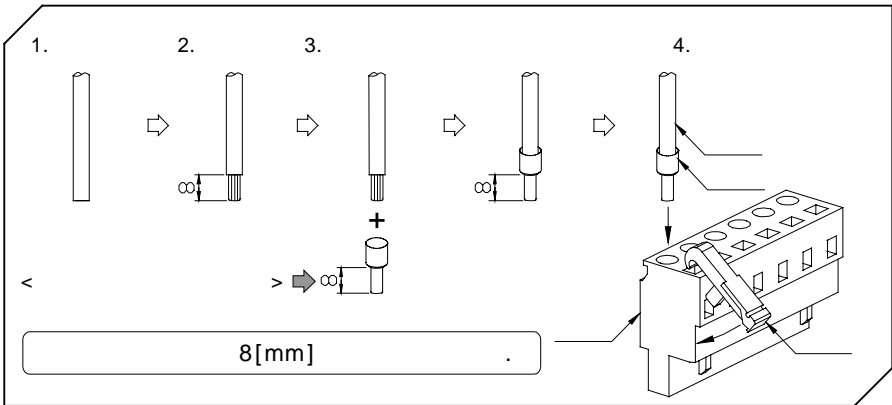

	Ø0.5~Ø0.8[mm]

	AWG28 ~ AWG12

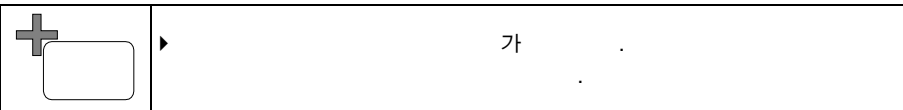
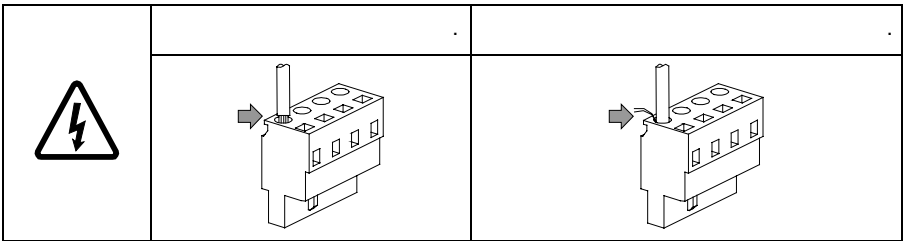

3.3

(CN1)

3.3.1

▶ Back-Up Battery CN5 CN1 49,25

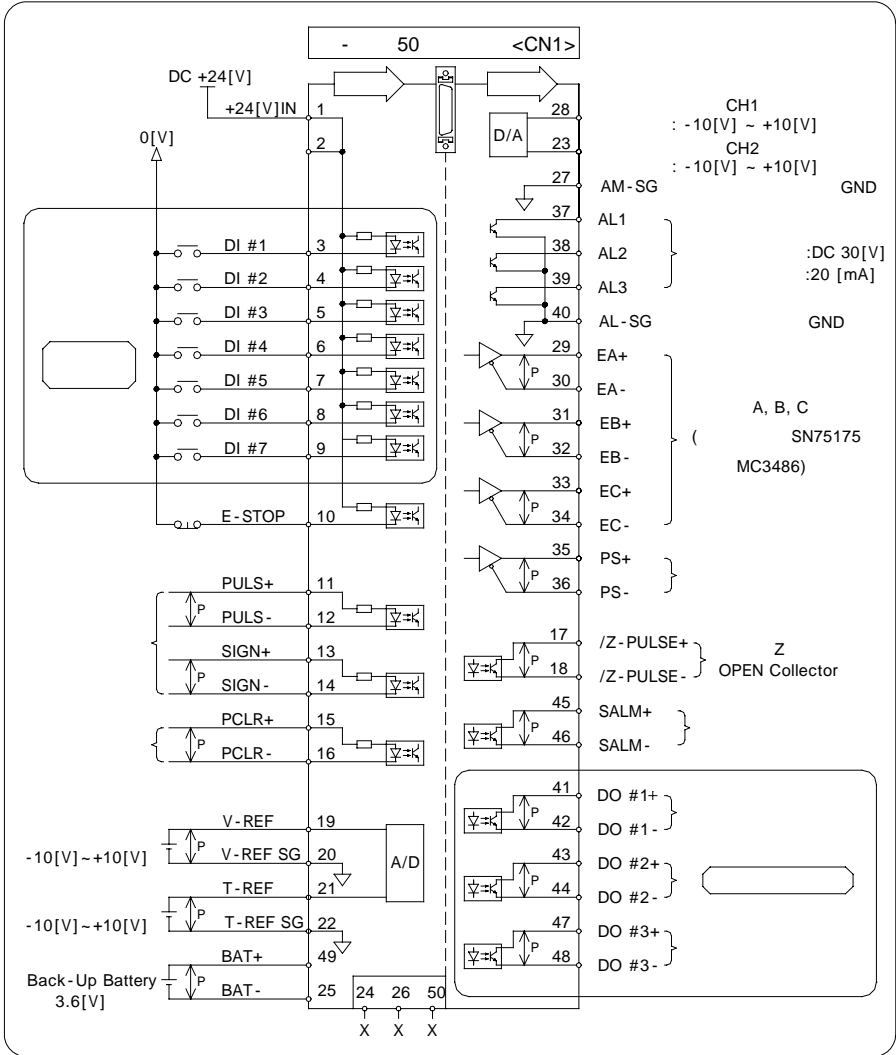

3.3.2 (CN1)

1	+24[V] IN		24[V]
2			
3	DI#1		5.1
4	DI#2		
5	DI#3		
6	DI#4		
7	DI#5		
8	DI#6	1	
9	DI#7	1	
10	E - STOP	1	

11	PULS+	1	()
12	PULS-	1	
13	SIGN+	1	
14	SIGN-	1	
15	PCLR+	2	
16	PCLR-	2	
17	Z-PULSE+	2	Z-PULSE
18	Z-PULSE-	2	()
19	V-REF	2	-10[V] ~ +10[V].
20	V-REF SG	2	

21	T-REF	2	-10[V] ~ +10[V].
22	T-REF SG	3	
23	AM-CH2	3	CH2. -10[V] ~ +10[V].
24	-	3	-
25	BAT-	3	GND.
26	-	3	-
27	AM-SG	3	GND.
28	AM-CH1	3	CH1. -10[V] ~ +10[V]
29	EA+	4	()
30	EA-	4	

31	EB+	4	()
32	EB-	4	
33	EC+	4	
34	EC-	4	
35	PS+	4	
36	PS-	/	
37	AL1	/	()
38	AL2	/	
39	AL3	/	
40	AL-SG	/	GND.

41	D0#1+	/	5.1 ()
42	D0#1-	/	
43	D0#2+	/1	
44	D0#2-	/1	
45	SALM+	/1	()
46	SALM-	/1	
47	D0#3+	/1	5.1 ()
48	D0#3-	/1	
49	BAT+	/1	3.6[V]
50	-	(Shield)	-

3.4 (CN1)

3.4.1 ()

5.1

</SV-ON> -ON	ON OFF	가	All	4.1.1
</A-RST>			All	7.10.10
</G-SEL>	ON OFF 2가	2	All	6.6.5
</P-TL>	가 ON	[Pr-4.03]	All	5.4.4
</N-TL>	가 ON	[Pr-4.04]	All	
</P-OT>	가	가	P S C	7.1.3
</N-OT>	가	가	P S C	
</P-CON> P	PI	P	P S C	6.6.3
</C-SEL>				5.6
</C-DIR> </C-SP1> </C-SP2> </C-SP3>	</C-SP1 ~ /C-SP3> 가	</C-DIR> 가 [Pr-2.05 ~ Pr-2.11]	C	5.5
</Z-CLP>		[Pr-5.04]	S	5.3.4
</INHIB>	가 ON		P	5.2.8
</ABS-DT>	가 ON	EA, EB	P	7.9.5

3.4.2 ()

1.

	+24[V]IN	가	+24[V]	ALL

2.

	E - STOP			ALL 3.6.4

3.

	PULS+		P	5.2
	PULS-			
	SIGN+			
	SIGN-			
	PCLR+		P	
	PCLR-			

	V - REF	(-10[V] ~ +10[V])	S	5.3
	V - REF SG			
	T - REF	(-10[V] ~ +10[V])	t	5.4
	T - REF SG			

4. (Battery)

	BAT+		ALL	7.9.3
	BAT-			

3.5 (CN1)

3.5.1 ()

5.1

/P-COM (+, -) ()	가 ON [Pr-5.00]	P	5.2.9
/NEAR (+, -) ()	가 ON [Pr-5.01]	P	
/V-COM (+, -) ()	[Pr-5.02] 가 ON	P S C	5.3.5
/TG-ON (+, -) ()	가 [Pr-5.03] ON	All	5.3.6
/T-LMT (+, -) ()	가 ON	All	5.4.4
/V-LMT (+, -) ()	가 ON	All	5.3.7
BK (+, -) ()		All	7.2
/WARN (+, -) ()	가 ON	All	8.2.1

	<p>▶ <></p> <p>▶ ex) </SV-ON>, </P-COM></p>
---	---

3.5.2 ()

1.

	AL1	3 bit . : DC 30[V], 20[mA]	ALL	8.2
	AL2			
	AL3			
	AL-SG			

2.

	AM-CH1	, . : -10[V] ~ +10[V].	ALL	7.8
	AM-CH2			
	AM-SG			

3.

	EA+	A, B, C . A, B .	ALL	7.7
	EA-			
	EB+			
	EB-			
	EC+			
	EC-			
S	PS+	.		
	PS-			

4.

	SALM+	.	ALL	7.8
	SALM-			

5. Z (Z-PULSE)

Z	Z-PULSE +	Z .	ALL	
	Z-PULSE -			

3.6 (CN1)

3.6.1

- ▶ 가 가
- ▶ 가 가

5.2

CN1		
PULS +, PULS- (11, 12)	SIGN +, SIGN- (13, 14)	PCLR +, PCLR- (15, 16)

1. - 900[kpps]

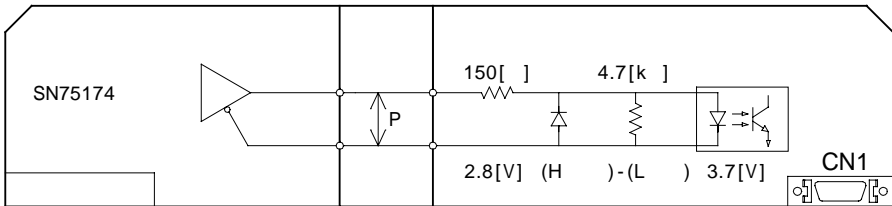

2. - 300[kpps]

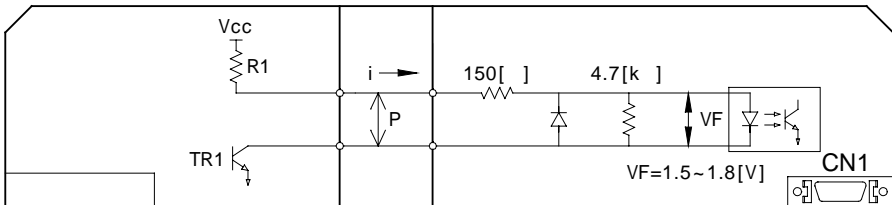

- ▶ (Pull Up) R1 이가 7[mA]~15[mA] 가

Vcc	24[V] ± 5[%]	12[V] ± 5[%]	5[V] ± 5[%]
R1	2.2[kΩ]	1[kΩ]	180[Ω]

+	<ul style="list-style-type: none"> ▶ 900[kpps]. ▶ 300[kpps] <p style="text-align: right;">“E.OvPUL”</p>
---	---

3.6.2

- ▶ 5[MΩ]
- ▶ -10[V] ~ +10[V]

CN1	
V-REF, V-REF SG (19, 20)	T-REF, T-REF SG (21, 22)

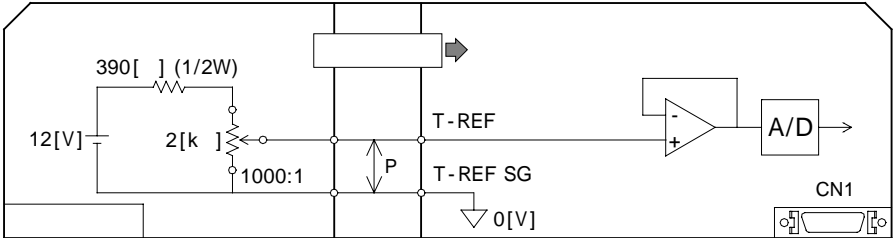
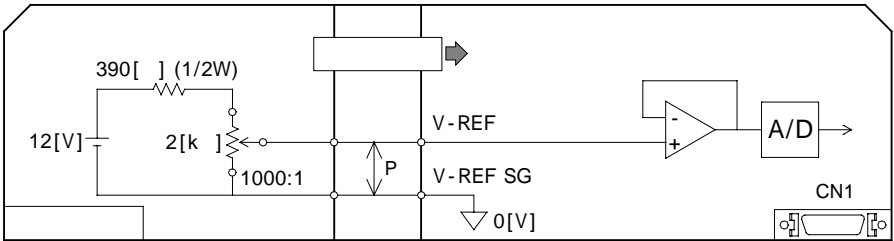

3.6.3

- ▶ 이가 7[mA]~15[mA] 가

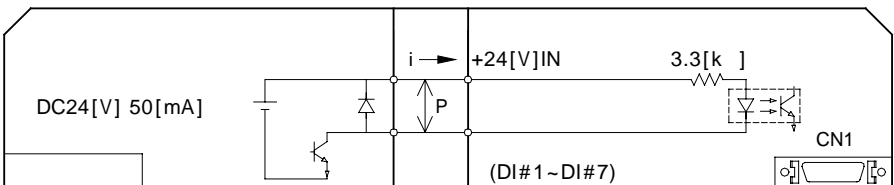
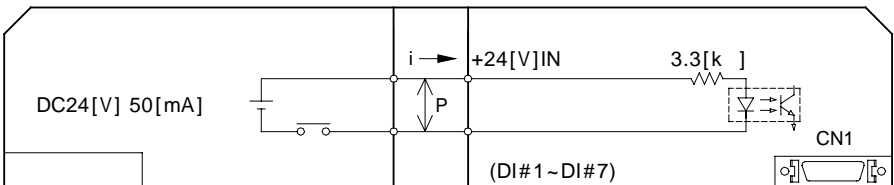

3.6.4

가



CN1 10



CN1 10

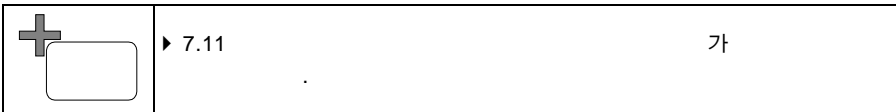
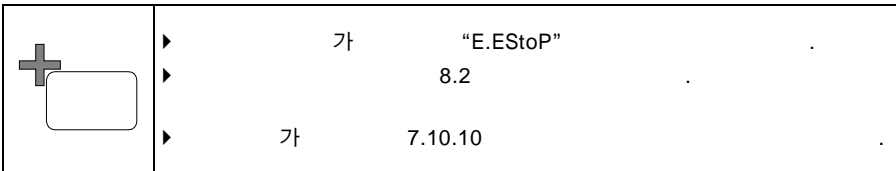
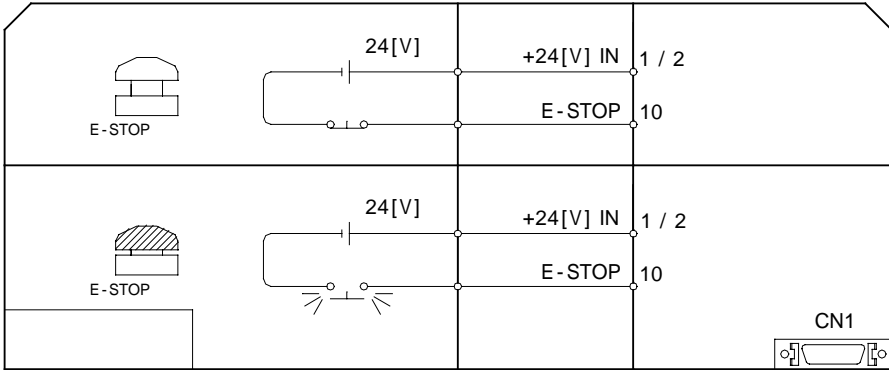

3.7 (CN1)

3 가

1.

EB-) 2 (A, B) (EA+, EA-, EB+, (EC+, EC-) S (PS+, PS-)가

▶ R1 330[Ω]

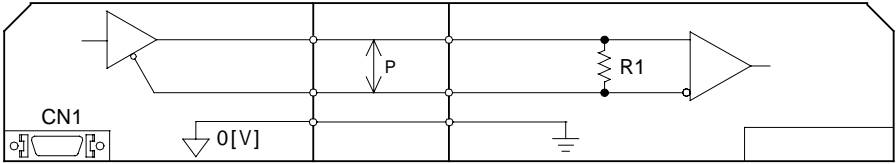

2.

▶ DC 30[V] 20[mA]

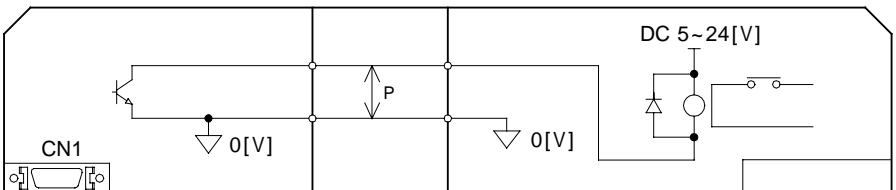
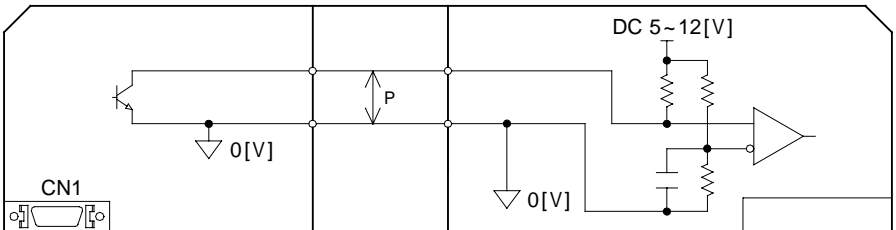
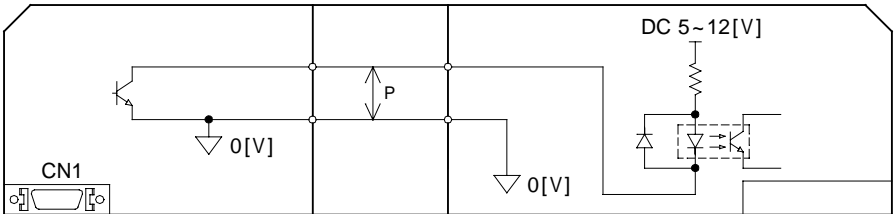

3.

Z

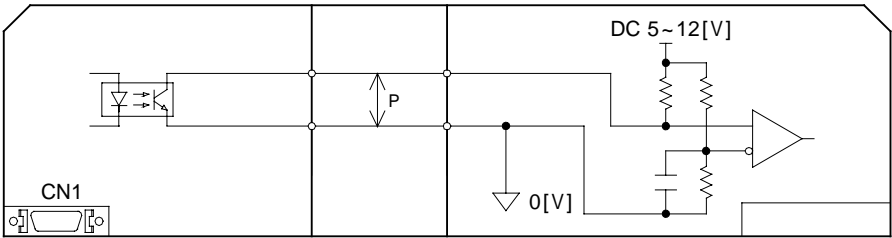
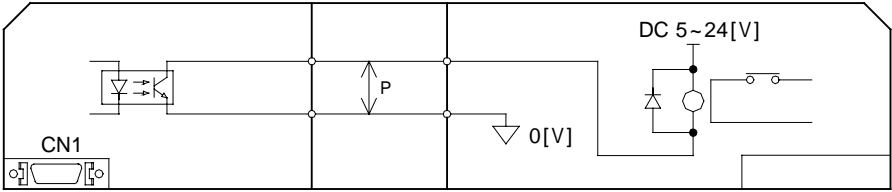

3.8

(CN2)

3.8.1 (CN2)

DRIVE		MOTOR										
PIN NO.		CSM, CSMG, CSMP			CSMD CSMF CSMS CSMQ	CSMZ CSMQ	CSMD, CSMF CSMS		CSMZ CSMQ	CSMK	CSMT,CSMR CSME,CSMW	
		9 Inc.	15 Inc.		800[W]	400[W]	15 Inc.	Compact	Full	15 Inc.	800[W]	800[W]
					11 Inc.	11 Inc.						
1	E0[V]	8	14	14	G	11	G	G	14	G	8	G
2												
3	A	1	1	1	A	1	A	A	1	A		
4	/A	2	2	2	B	2	B	B	2	B		
5	B	3	3	3	C	3	C	C	3	C		
6	/B	4	4	4	D	4	D	D	4	D		
7	C	5	5	5	E	5	E	E	5	E		
8	/C	6	6	6	F	6	F	F	6	F		
9												
10	U		7	7	P	8	K	K	11	K	4	K
11	RST			9				R	9			
12												
13	/U		8	8	R	9	L	L	12	L	5	L
14	V		9				M			M		
15	/V		10				N			N		
16	W		11				P			P		
17	/W		12				R			R		
18	BAT+			11				T	7		1	T
19	BAT-			12				S	8		2	S
20	E5[V]	7	13	13	H	10	H	H	13	H	7	H
	Frame FG	9	15	10 15	J	12	J	J	10 15	J		J

3.8.2 (CN2)

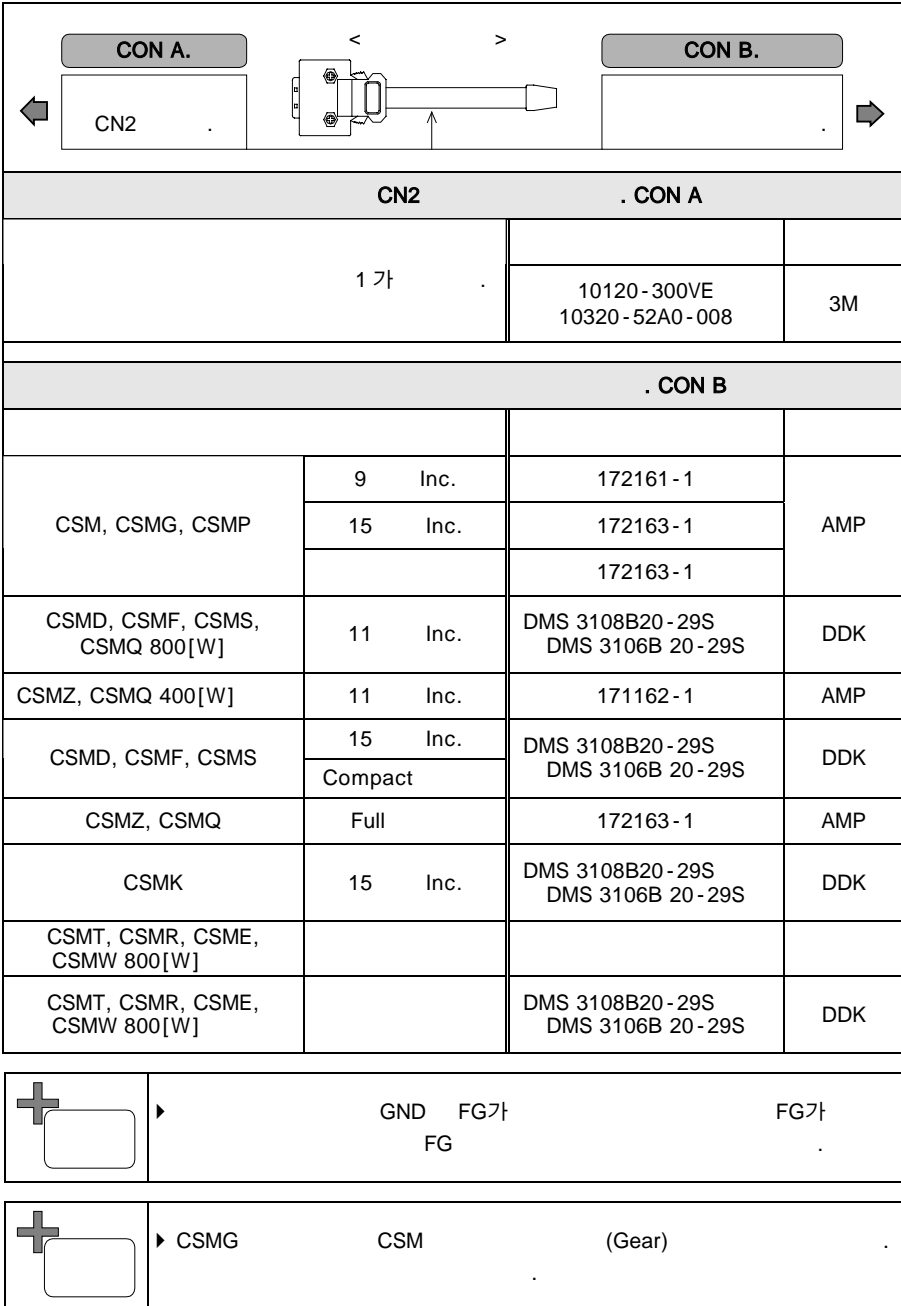

3.8.3

1. CSM, CSMG, CSMP

(9 Inc.)

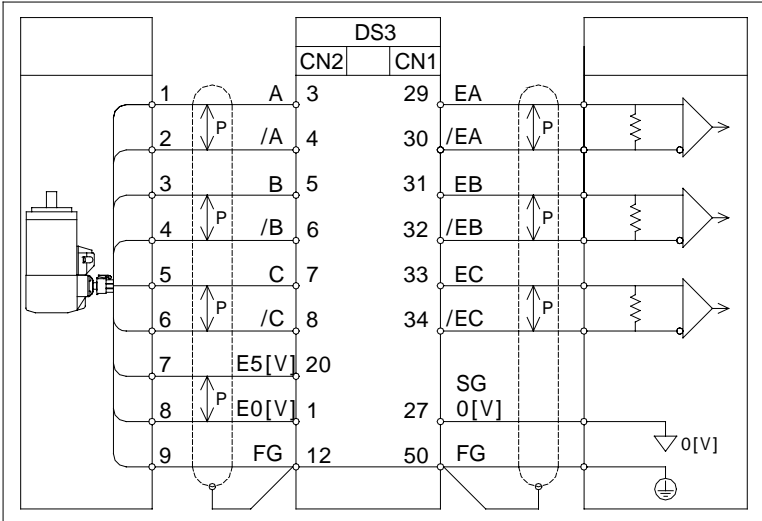

2. CSM, CSMG, CSMP

()

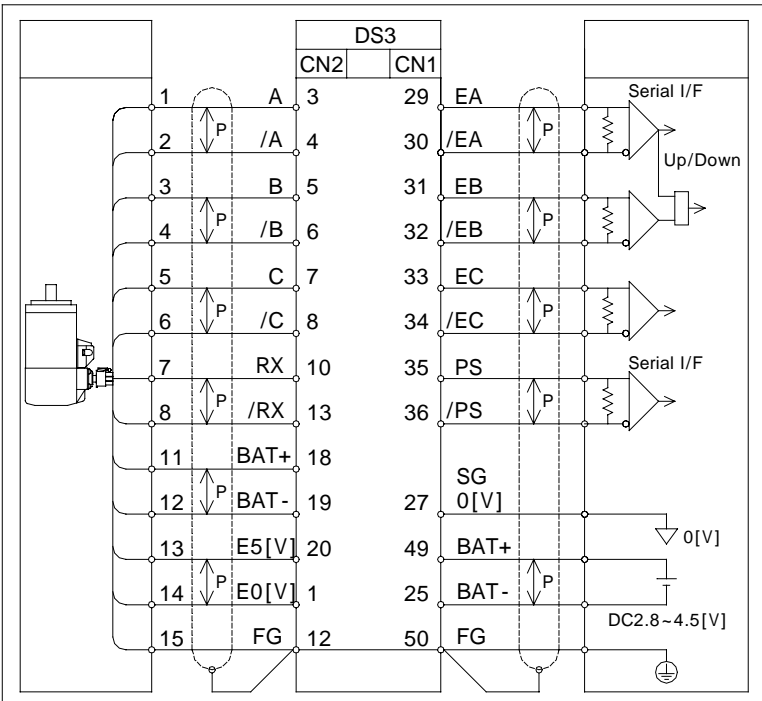

3. CSMD /F/H/S

(11 Inc.)

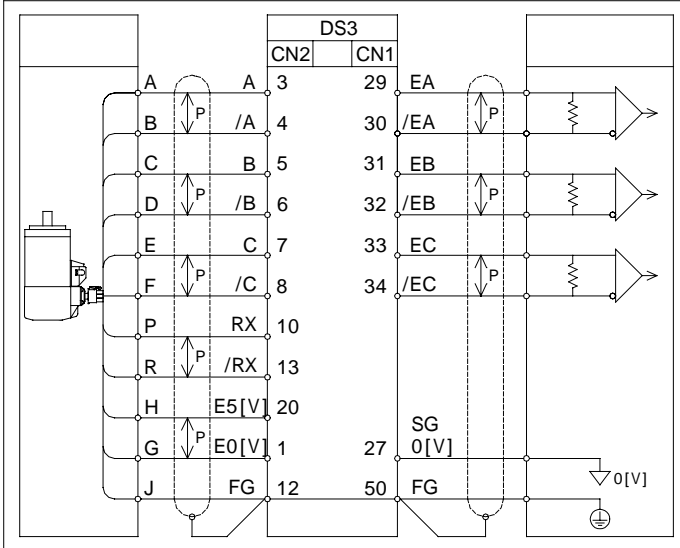

4. CSMD /F/S/H/N/X/K

(15 Inc.)

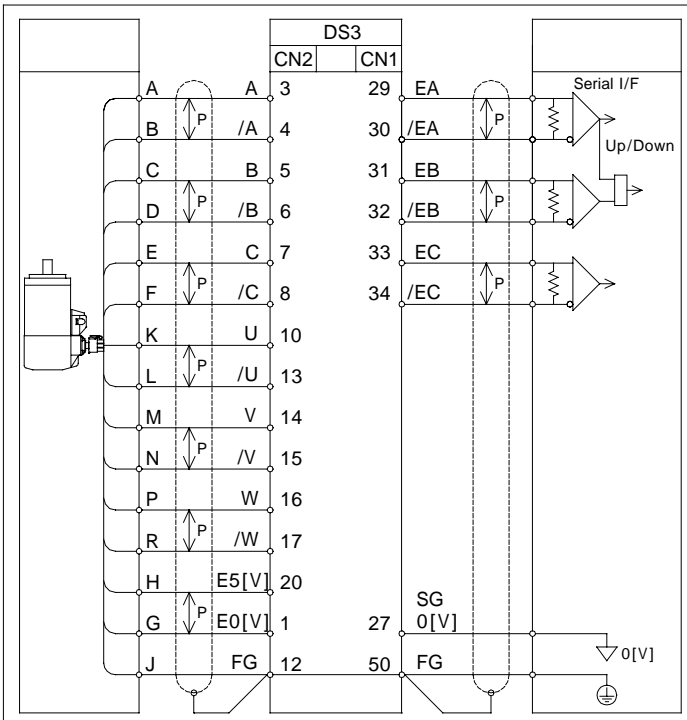

5. CSMQ /Z

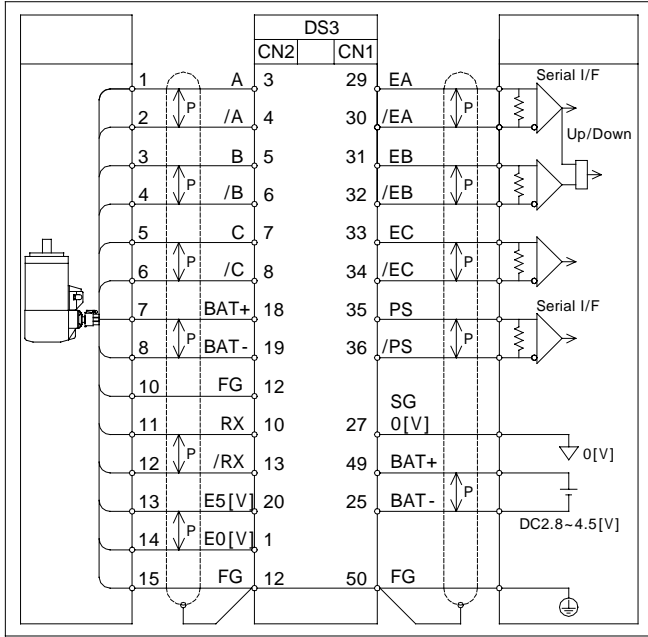

6.

(CSMT /R/E/W)

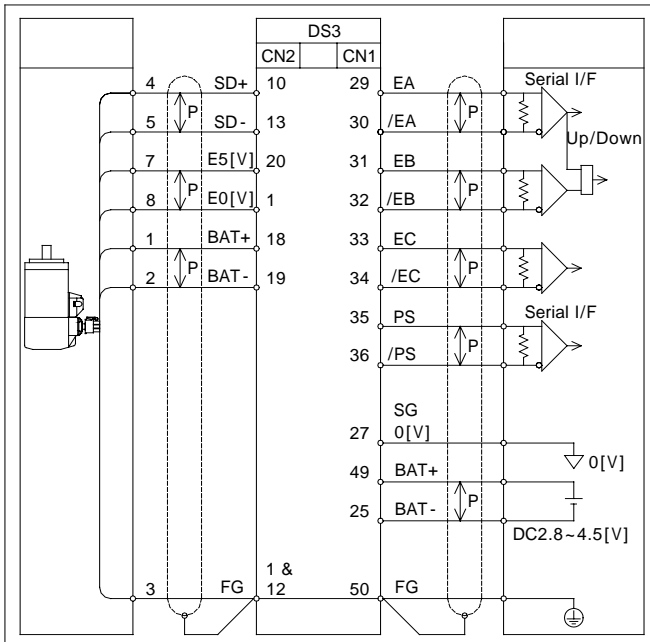

3.9

(CN5)

1.



CN5

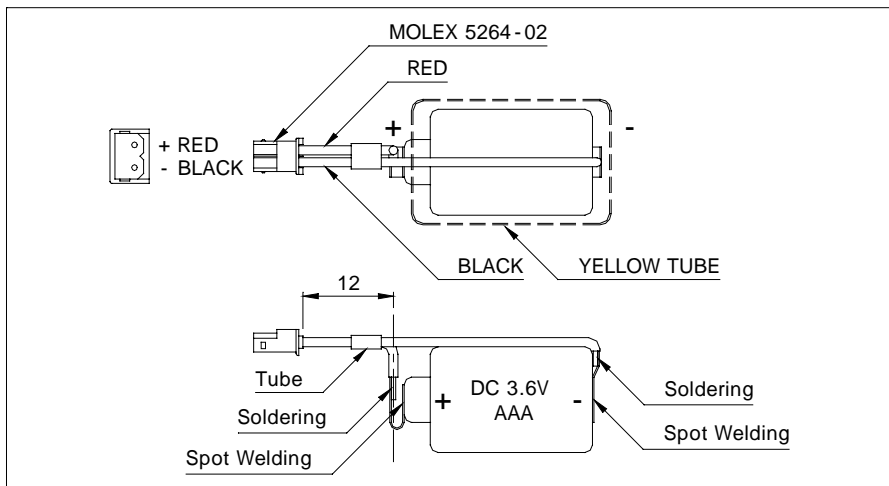

2. CN5



CN5

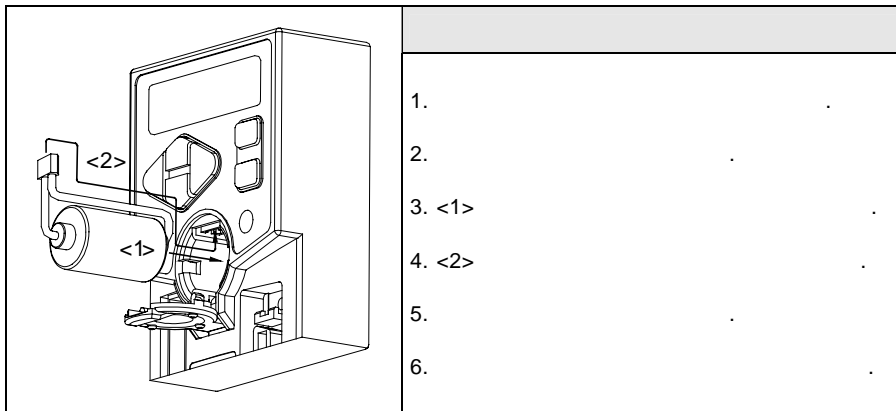

3.10

3.10.1

1.

- ▶ 가
- ▶ 3 (: 100[])
- ▶ 1
- ▶ AC, L1, L2, L3 L2 가
- ▶ 가 (30[cm])
- ▶ 가
- ▶ 가 1

2.

- ▶ 가 가
- ▶ (CN1) (CN2) (twist pair) (shield) . (
- ▶ 가
- ▶ 가 0[V] (SG)

3.

- ▶ 가 가
- ▶ 가 가
- ▶ (surge suppressor)

3.10.2

			1 [kVA]	MCCB [Arms]
		CSD3-		
220V	30[W]	A3BX1(P)	0.20	4
	50[W]	A5BX1(P)	0.25	
	100[W]	01BX1(P)	0.40	
	200[W]	02BX1(P)	0.75	
	400[W]	04BX1(P)	1.2	8
3 220V	1[KW]	10BX1(P)	2.3	8
	1.5[KW]	15BX1(P)	3.2	10
100[%] 가 . MCCB () : 200[%] -2 . 700[%] - 0.01				

 	가
--	---

3.10.3

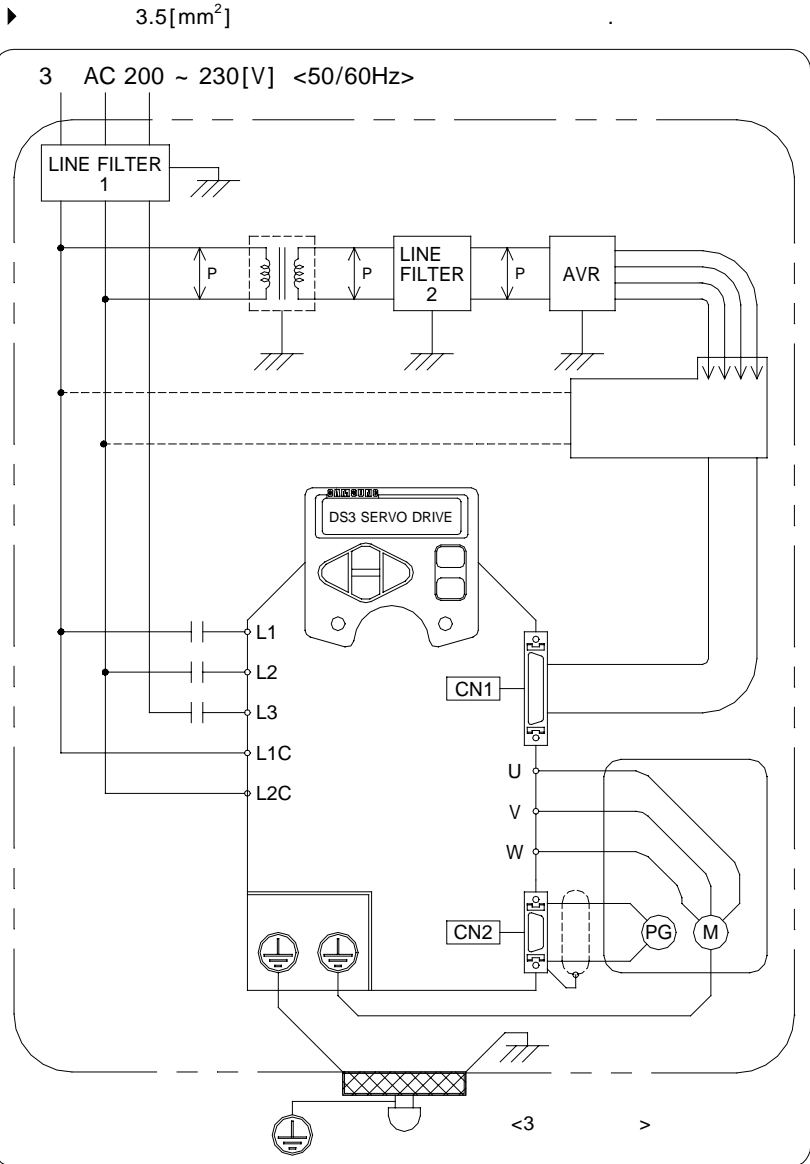

가

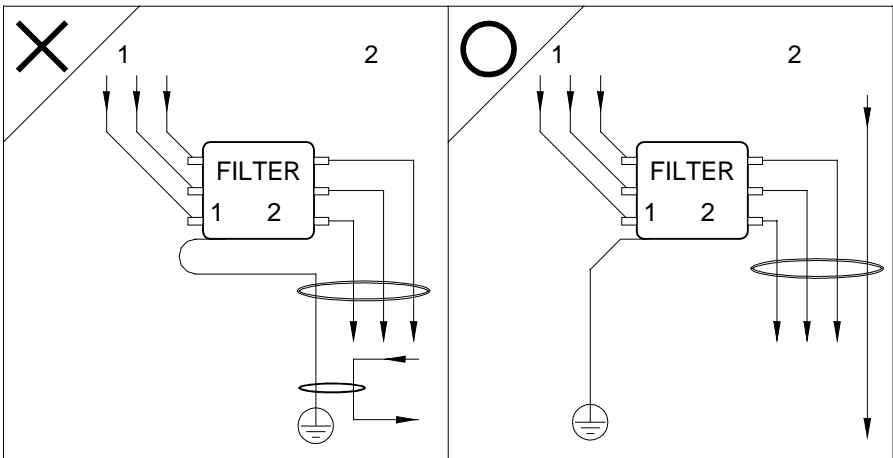
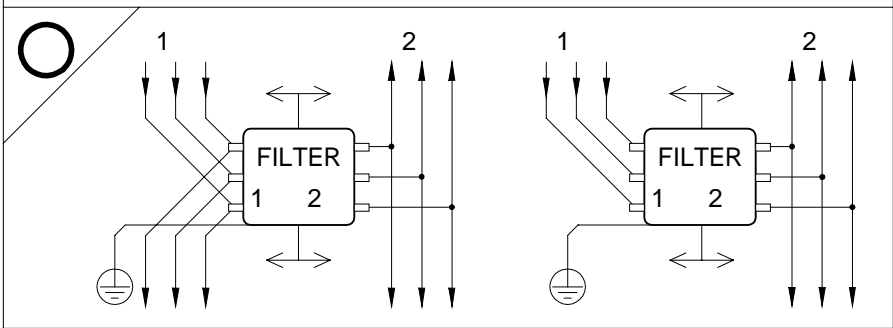
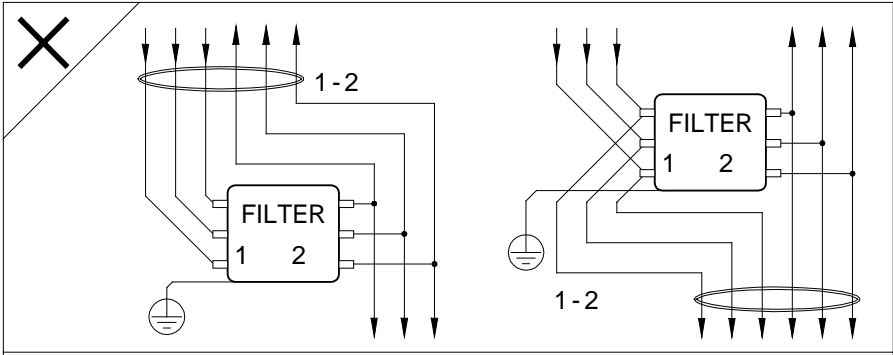

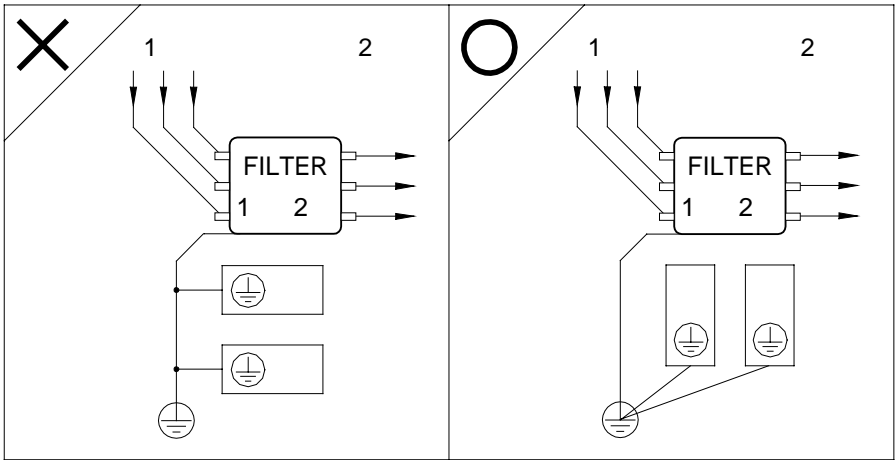

▶ () 가

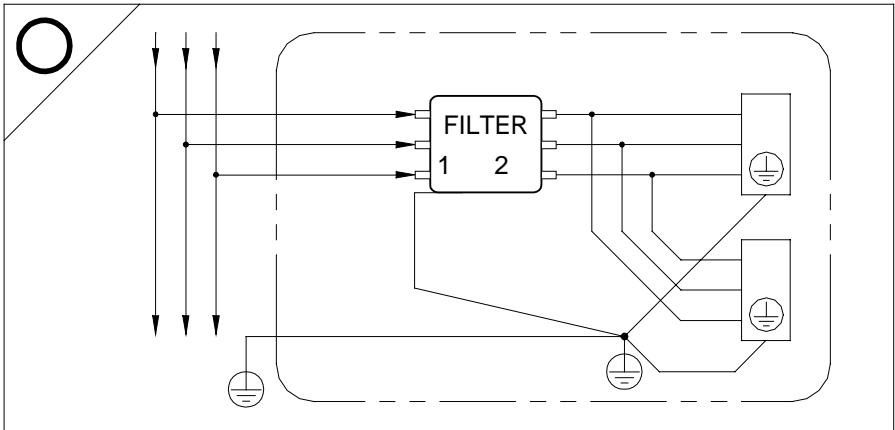

3.10.4

- ▶ (SALM)
- Relay1 SALM+ SALM-
- Relay1 24[V]가
- ▶ Relay1 24[V]가

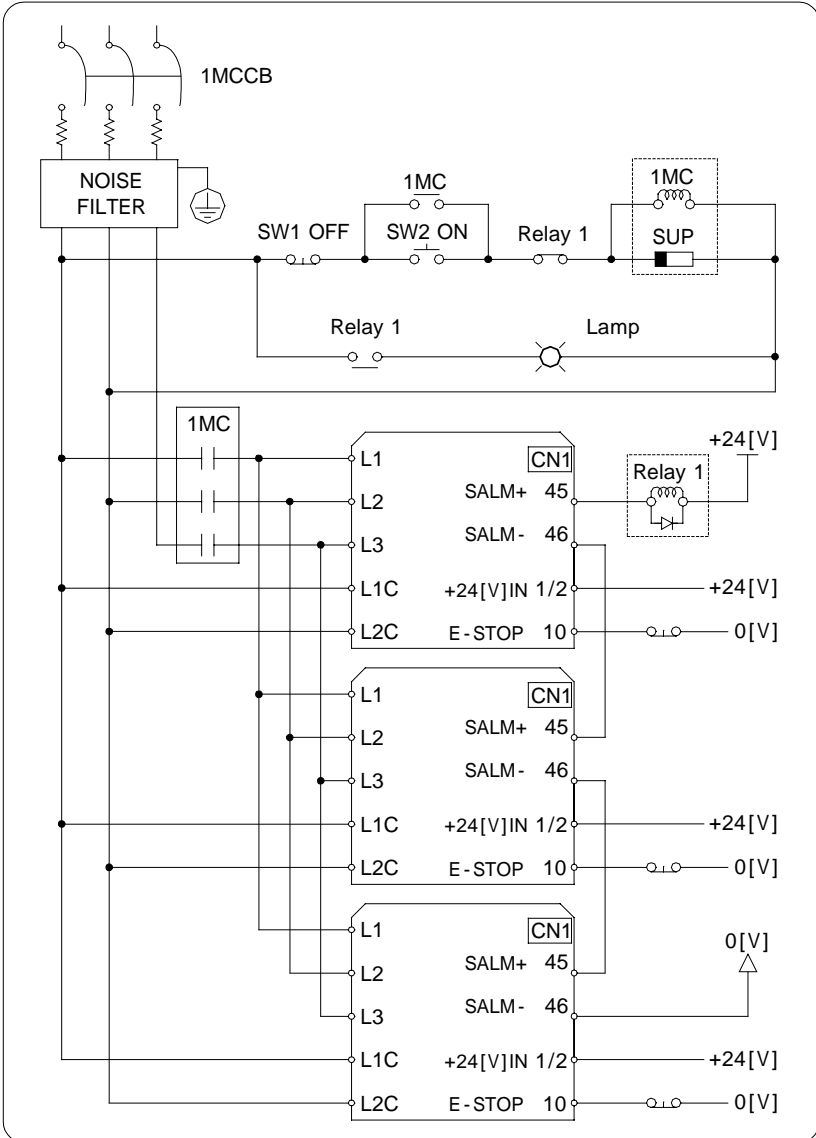

3.10.5

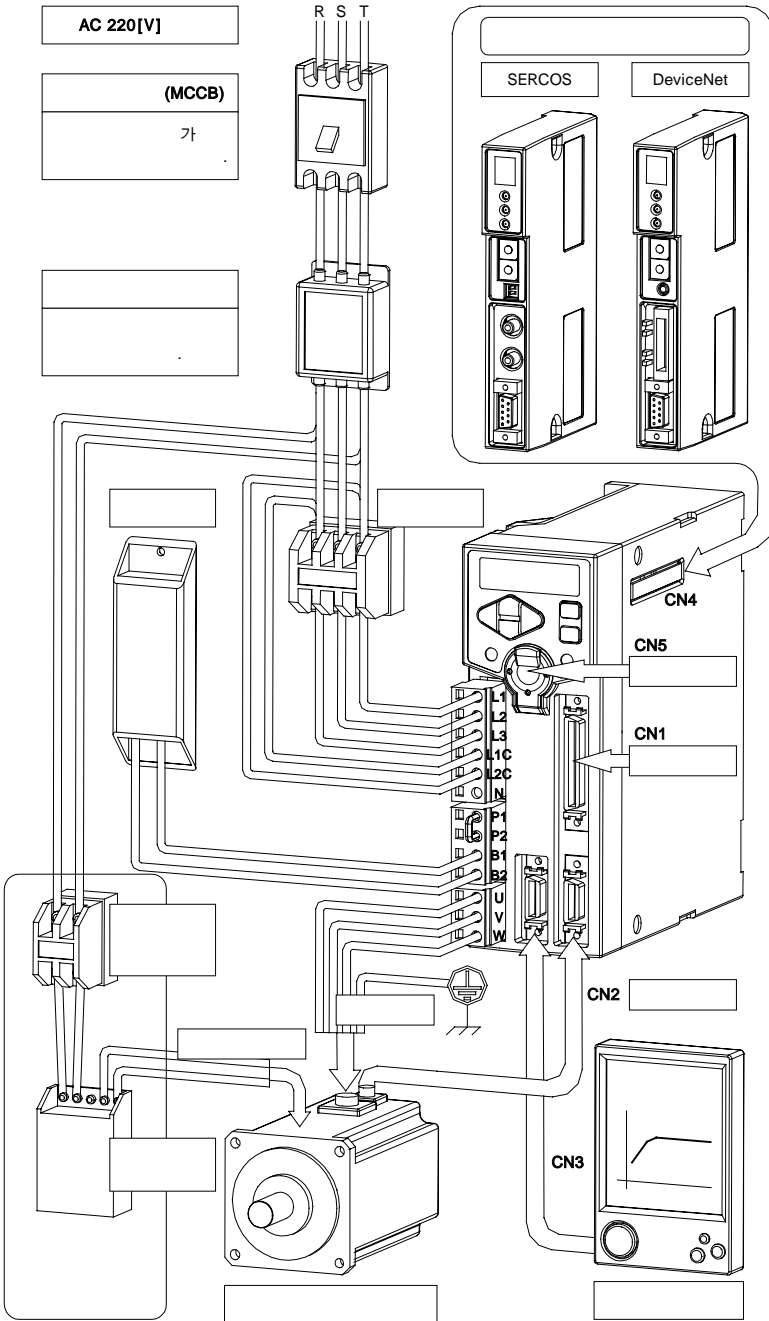

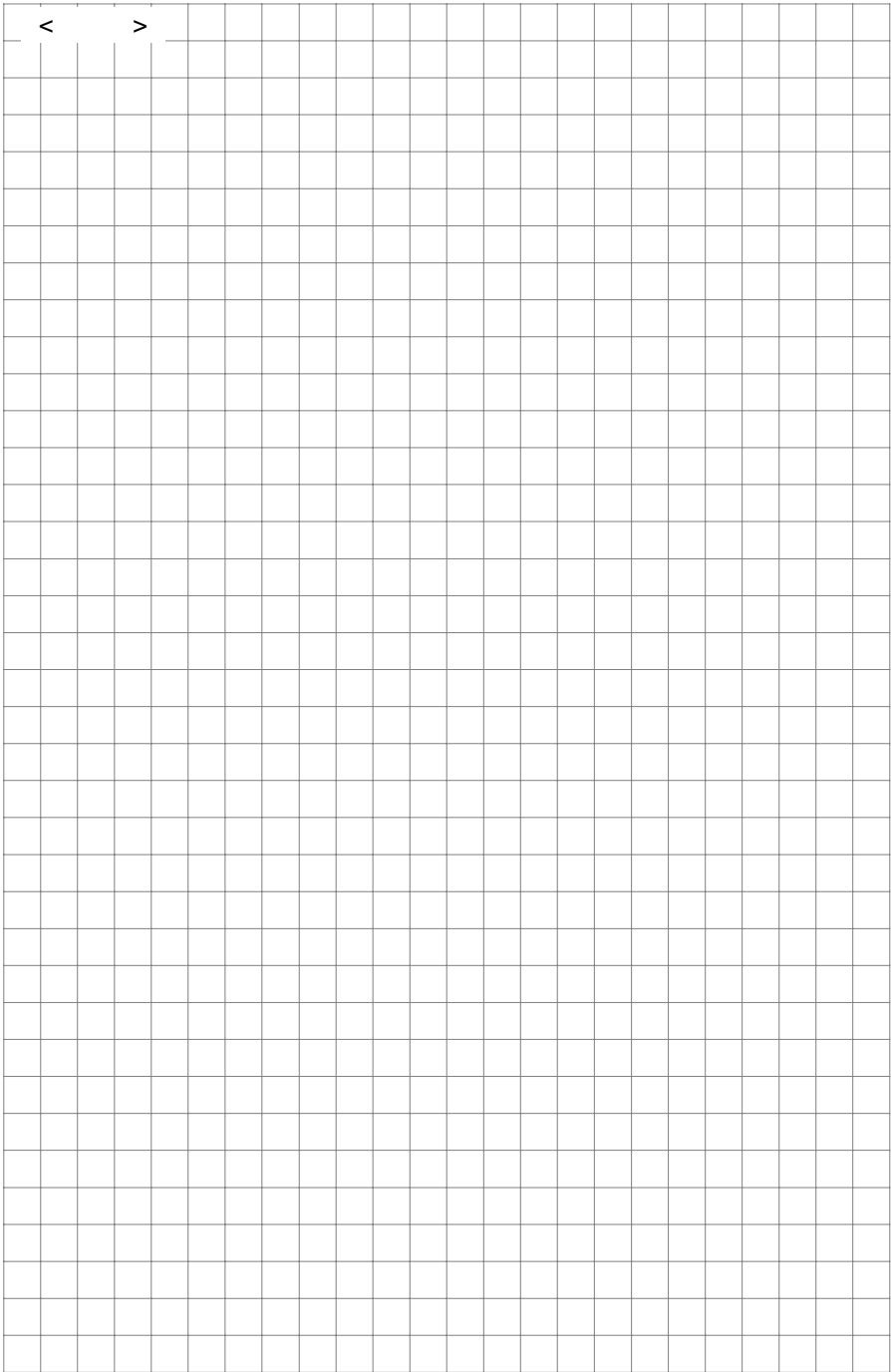

4.1	56
4.1.1	-ON	56
4.1.2	58
4.2	59
4.2.1	59
4.2.2	60
4.2.3	60
4.2.4	61
4.2.5	62
4.2.6	63
4.2.7	64
4.3	65
4.3.1	65
4.3.2	66
4.3.3	69
4.3.4	72
4.4	74
4.4.1	74
4.4.2	74
4.4.3	76

4.1

4.1.1 -ON

-ON

1. -ON

ON

가

가

-ON 가

-ON 가 가

-OFF

2. -OFF

-ON

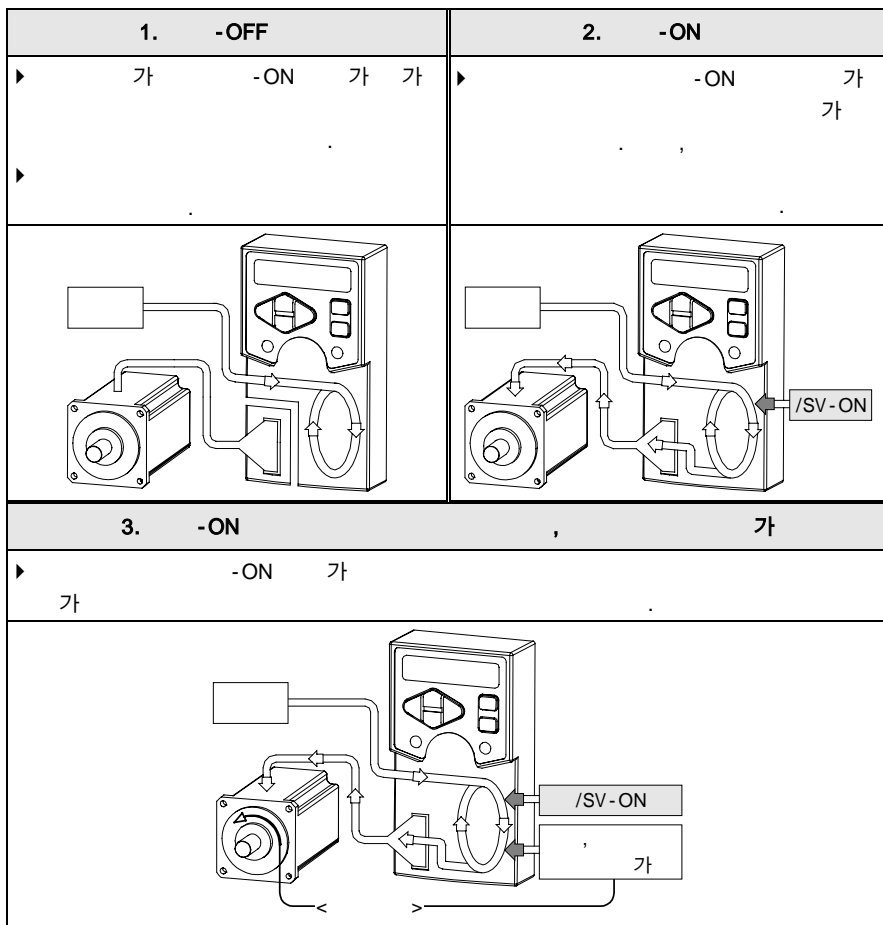

3. -ON

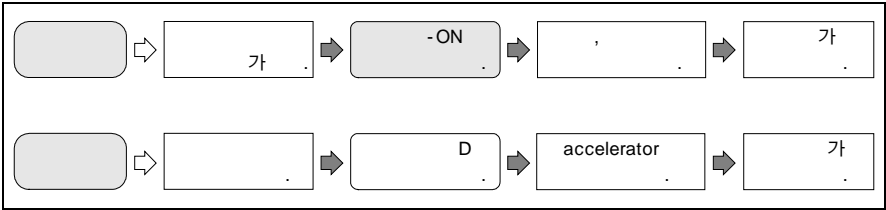

- ▶ 가 'D' -ON 가
- ▶ , -OFF

4. -ON

-ON, </SV-ON>	-OFF
---------------	------

5. -ON

-ON CN1
5.1

6. -ON

(run-00), (run-01) 가
-ON

- ▶ (run-00), (run-01) 7.10
- ▶ , (run-00) 4.4
- ▶ (run-00), (run-01), (run-07), (run-08), (run-10), (run-12) -ON

7. -ON

-ON 가 가 -OFF 가
(7.10.10) -ON
가 -ON 가
▶ 8.2.2

 	▶ 4	-ON -OFF
	▶ ON	-OFF 가 -

4.1.2

1.

Pr - 0.02		88.8888	
↑	↑	↑	
	0		
	1		
	ALL		-OFF> > 가>

2.

▶	
▶	Enter
▶	가 (" ") 가
	2가
	가
▶ <	> 가

▶ <	>	
	(ALL)	
	P	S
	t	C
▶	2가	
▶ ex)	- (SP), - (TS).	

▶ <	> 4.1.1
	-ON -OFF
	>
	-OFF > > -OFF
	-OFF> > 가> -OFF 가

4.2

4.2.1

가

- ▶ 6 7- LED
- ▶
- ▶
- ▶

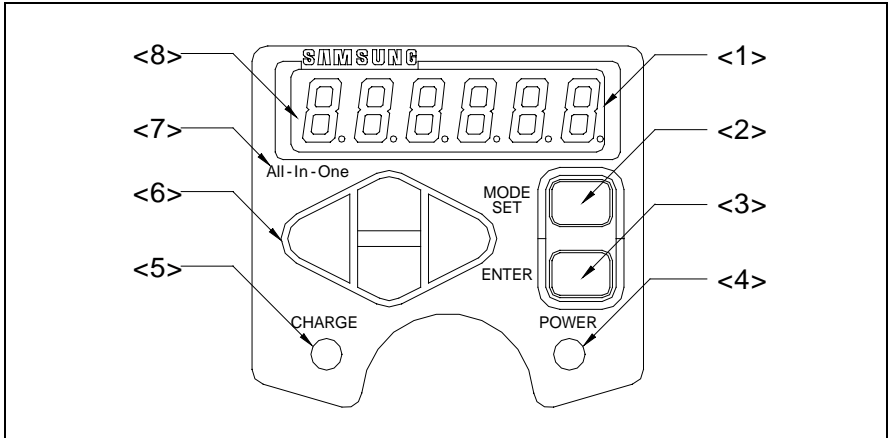

1	7- LED	6 7- LED
2	MODE/SET	
3	ENTER	
4		가
5		가
6		7- LED UP/DOWN
7	Type	All-In-One Position-Control-Only Type
8		All-In-One (RED) Position-Control-Only (GREEN)

4.2.2



		가 가			
				MODE/ SET	
				ENTER	가

4.2.3

4가 가



- ▶ MODE/SET
- ▶ 4가

가

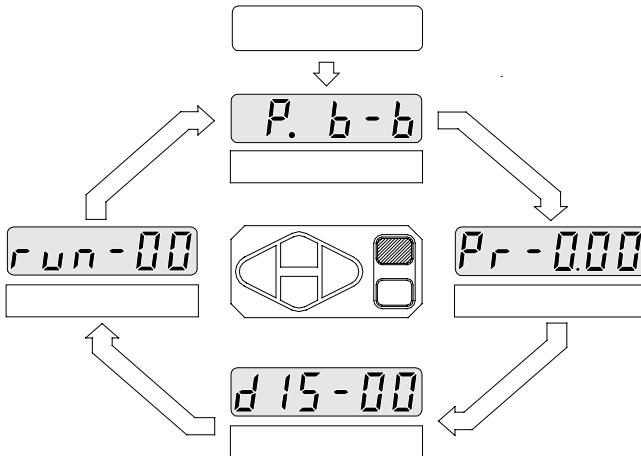

	▶	가 가
	▶	

4.2.4

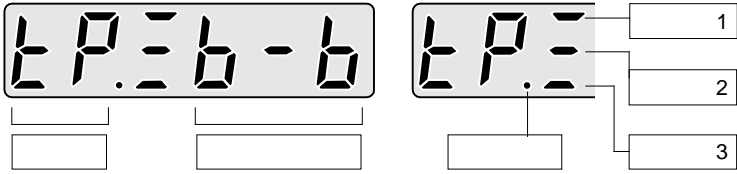

	---	P	--S	P	-
	--S-		-LS-		-
	-L--		-L-P		-
	[---		[--P		-
			[S-		-
			[L--		-
▶	가		-ON ()		
▶			2가		
			가		가

	8885Er	888dnt		
	SERCOS	DeviceNet		1.4
	888b-b	BASE - BLOCK,	-OFF	
	888run			
	888Pot		가	
	888not		가	
▶				
▶	8			

4.2.6

- ▶ 가
- ▶ 가
- ▶
- ▶

d 15-00		d 15-18			
	()		()		()
00	[rpm]	07	[kpps]	14	[mV]
01	[rpm]	08	[°]	15	
02	[rpm]	09	[°]	16	
03	[%]	10	[%]	17	
04	[pulse]	11	DC Link [V]	18	
05	[pulse]	12			
06	[pulse]	13	[mV]		

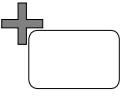
	▶	(5 , 10)
	▶	7.11

4.2.7

- ▶
- ▶
- ▶
- ▶

가 가 가 . 7.10

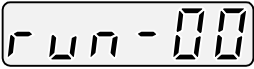
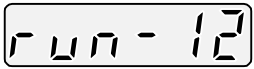
			
00	(Jog)	07	
01	-	08	
02		09	
03		10	
04		11	2
05		12	
06			

 	▶ 7.10
---	--------

4.3

4.3.1

1. 가
2. 가
3. 3가 가
4. [run-12] .()
5. 가
.()
3 3가

1		()
2		<ol style="list-style-type: none"> 1. 2. () 3. Type
3		()

▶ 가
.5

▶ 3가
▶

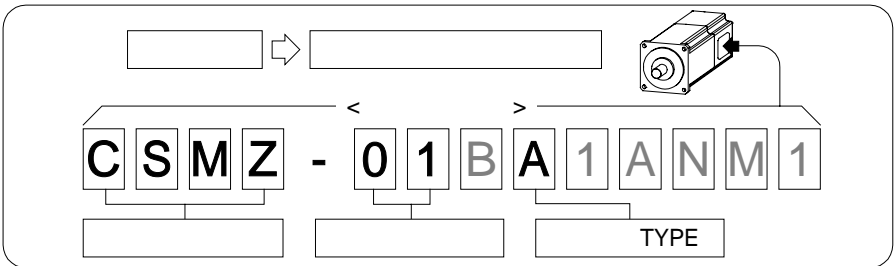

4.3.2

1.

4가

6가

가

▶

가

▶

3가

2가

▶

5

---	P	--S	P
			-
--S-		-tS-	
			-
-t--		-t-P	
			-
[---		[--P	
			-
		[S-	
			-
		t--	
			-

2.

▶ 가

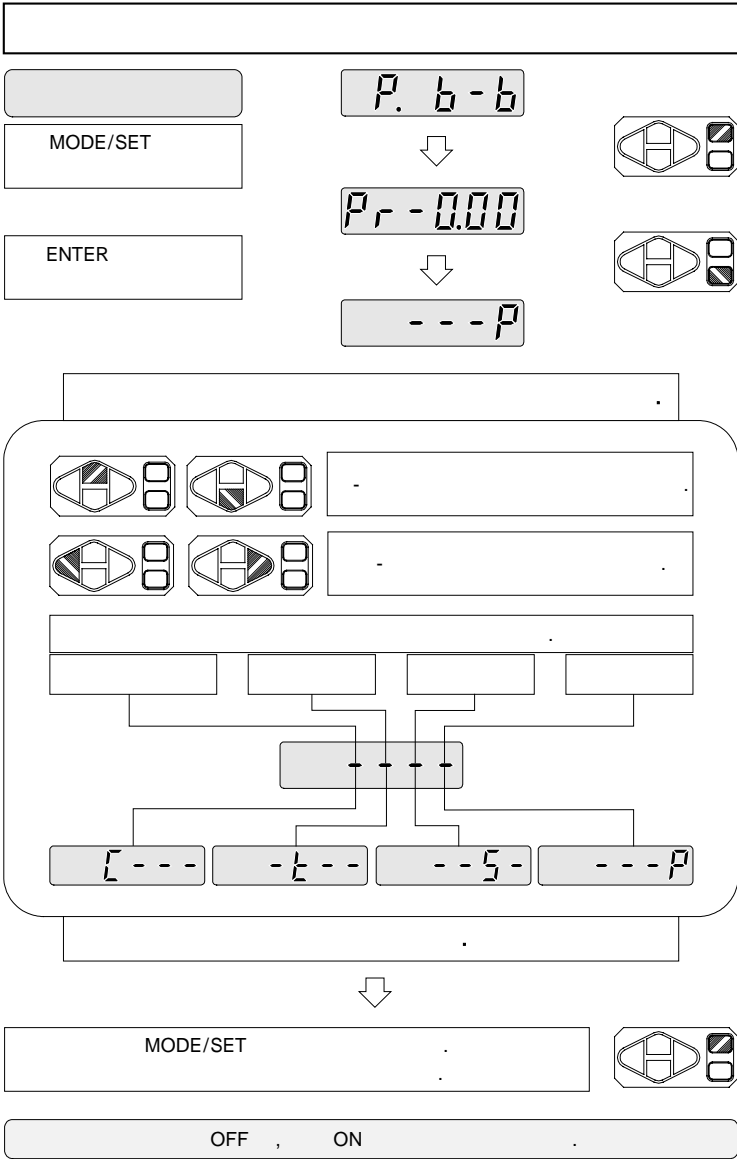

4.3.3

3가

▶ 가

3가

▶ [Pr-0.01] [Pr-0.01]

가

()

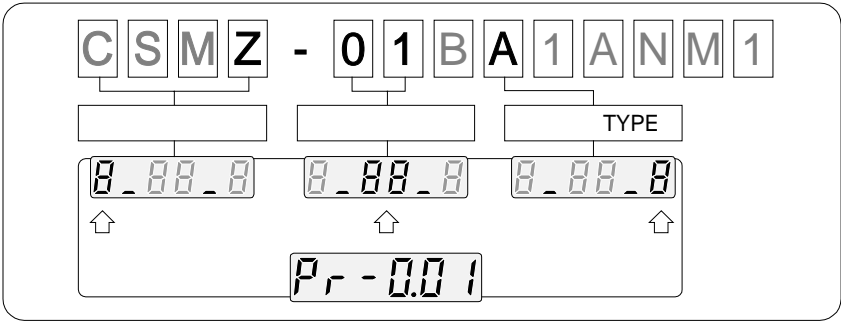

1.

4

CSM

3

CSM

- . 00 . 0	CSM	d . 00 . 0	CSMD	r . 00 . 0	CSMR
P . 00 . 0	CSMP	H . 00 . 0	CSMH	E . 00 . 0	CSME
9 . 00 . 0	CSMQ	F . 00 . 0	CSMF	U . 00 . 0	CSMW
2 . 00 . 0	CSMZ	K . 00 . 0	CSMK		
5 . 00 . 0	CSMS	t . 00 . 0	CSMT		

2.

()

()

0 . A3 . 0	30[W]	0 . 01 . 0	100[W]	0 . 10 . 0	1[kW]
0 . A5 . 0	50[W]	0 . 02 . 0	200[W]	0 . 15 . 0	1.5[kW]
⋮		⋮			

3. Type

Type (Type T, R, E, W)

Type

Type 1			Type 2		
: CSMT, CSMR, CSME, CSMW					
	/1	Type		/1	Type
	131072			131072	Inc.
: CSM, CSMP			: CSMD, CSMF, CSMF, CSMS CSMQ, CSMZ, CSMK		
	/1	Type		/1	Type
	2048	15 Inc.		2500	11 Inc.
	2048	9 Inc.		2500	15 Inc.
	2048			1000	15 Inc.
	2500	15 Inc.		2048	Compact
	2000	15 Inc.		2048	Full
	5000	15 Inc.		10000	15 Inc.

4.

Type (), Type
1 2
가

- ▶ Type (A, B, S, K, C, D)
- ▶ Type 2 Type (A, M, J, H, D, B)
- ▶ Type (Q, R) CSMT/R/E/W

CSM-A3B2ANT3	CSMZ-02BH1ANM3	CSMT-04BQ1ANT3	CSME-10BR1ANM3

5.

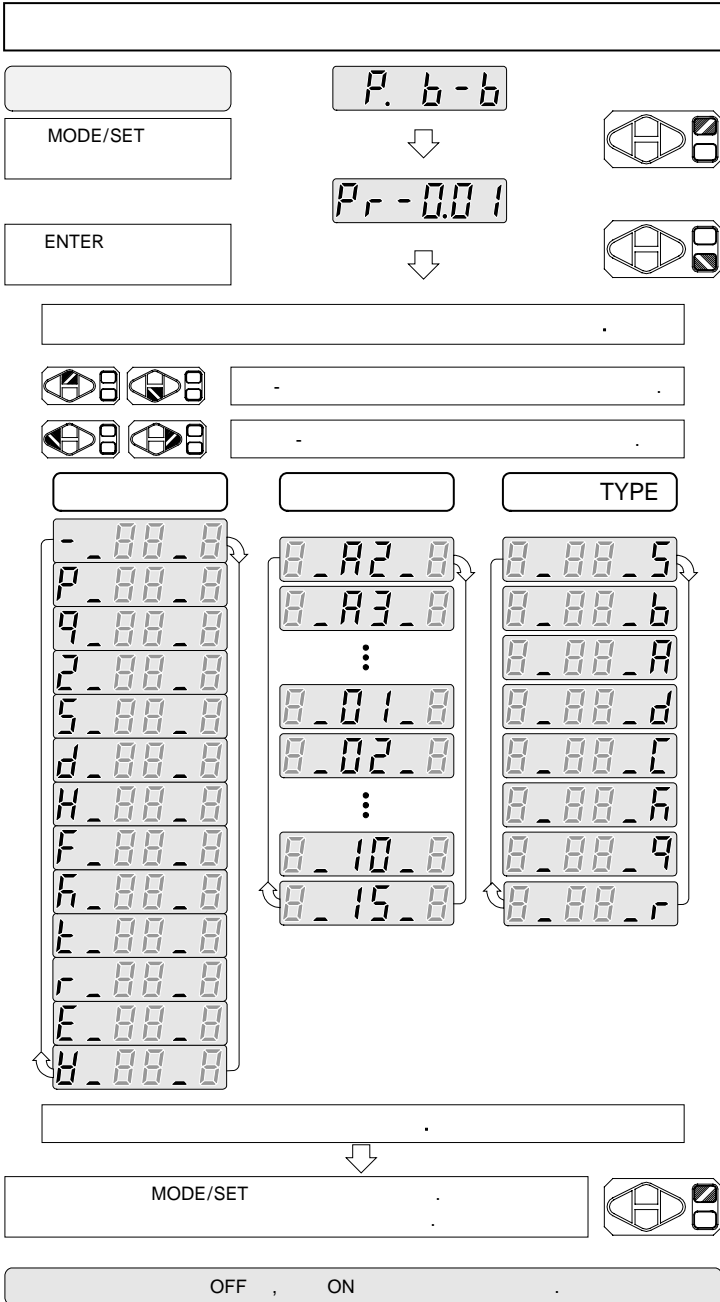

4.3.4

1.

(3.2 3.2 27†).

- ▶ L1,L2,L3 AC
- ▶ DC
- ▶

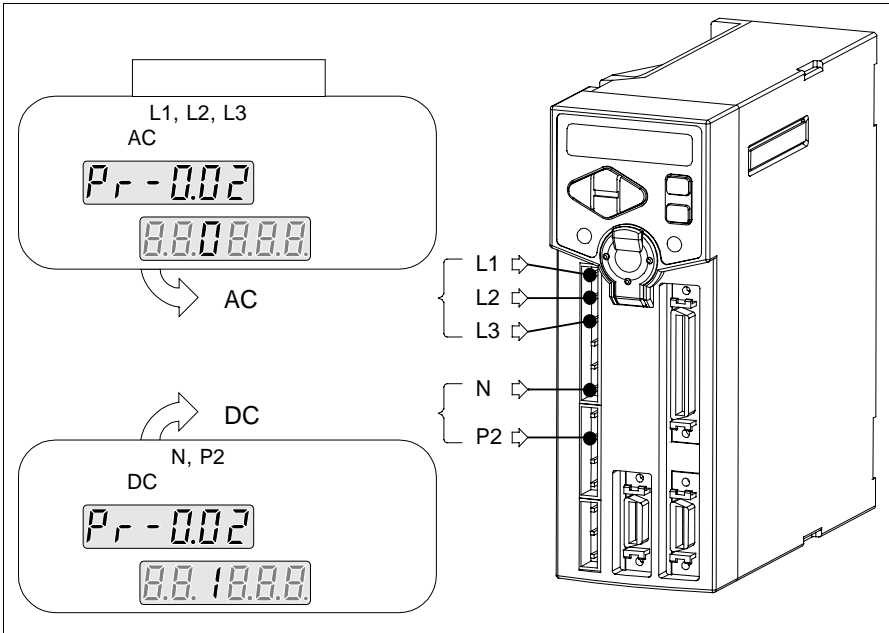

▶

Pr-5.10				
				OFF > >
20~1000	20	[msec]		ALL
▶ (Temporary power down)				
▶				(E.AcoFF)
. 8.2.2				

+	▶	[Pr-0.02]	DC
---	---	-----------	----

2.



가

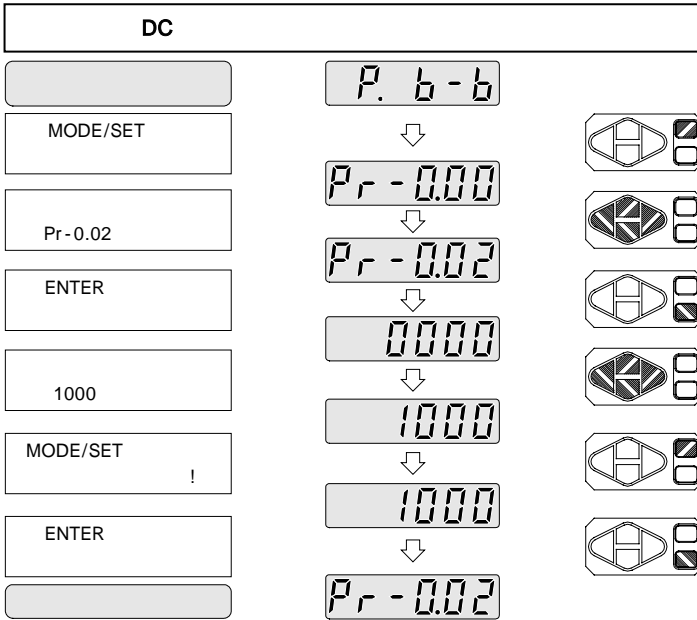

가



가



(7.10.14)

(,)

)



가

5

4.4

4.4.1

1. 3
- 2.
3. 4.2
- 4.

가 가

4.4.2

1. (1)

- ▶ -OFF 가
- ▶ -OFF 가 가
- ▶
- ▶ 500[rpm]
- ▶ 1 500[rpm]
- ▶

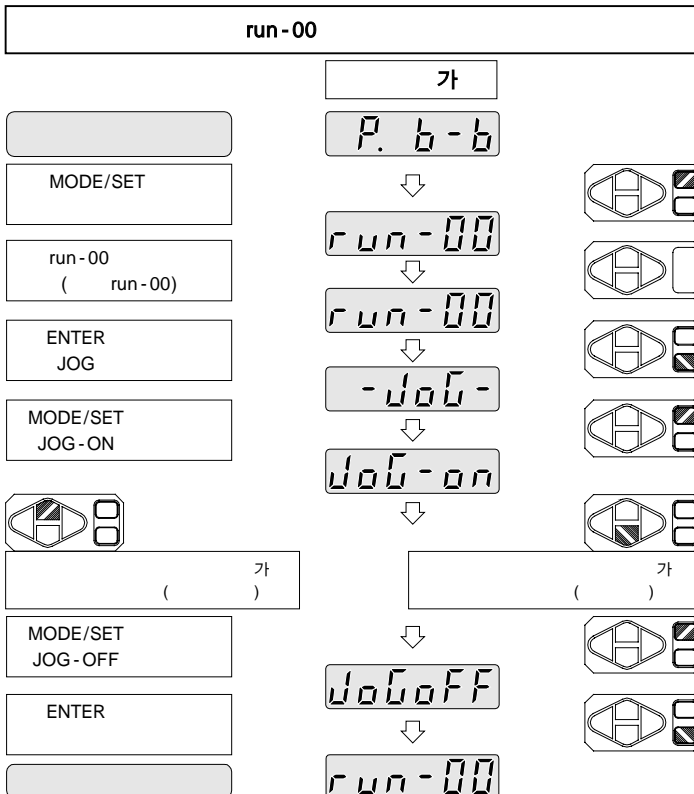

2.

. (2)

- ▶ 500[rpm] 1000[rpm]
- ▶ [Pr-2.01]
- ▶ 0~5000[rpm] 500[rpm]
- ▶

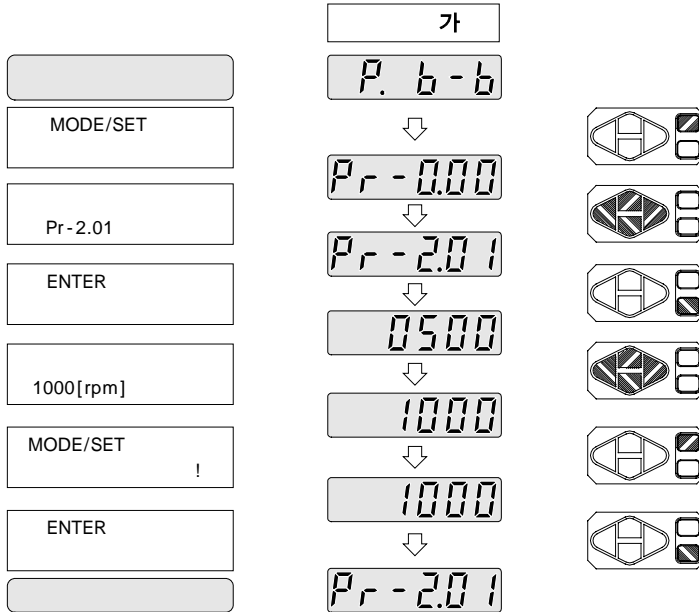

- ▶ MODE/SET
- ▶ [run-00]
- ▶ 500[rpm] 1000[rpm] 가

 <div style="border: 1px solid black; width: 40px; height: 40px; margin: 5px auto;"></div>	▶ 7.10.3
---	----------

	▶
---	---

	▶ (E-STOP) ▶ 3.6
---	---------------------

4.4.3

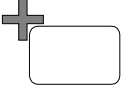
	▶ 7.10.3 -
---	------------

5.1	78
5.1.1	?	78
5.1.2	79
5.1.3 ! 가	.
5.1.4	81
5.1.5	82
5.1.6	83
5.2	84
5.2.1	84
5.2.2	85
5.2.3	86
5.2.4	88
5.2.5	89
5.2.6	90
5.2.7	(PCLR)	96
5.2.8	</INHIB>	97
5.2.9	</P - COM>, </NEAR>	98
5.2.10	100
5.2.11	Timing diagram	100
5.3	101
5.3.1	101
5.3.2	102
5.3.3	103
5.3.4	</Z - CLP>	104
5.3.5	</V - COM>	105
5.3.6	</TG - ON>	106
5.3.7	</V - LMT>	107
5.4	108
5.4.1	108
5.4.2	109
5.4.3	110
5.4.4	</T - LMT>	112
5.5	115
5.5.1	115
5.5.2	116
5.5.3	117
5.6	</C - SEL>	119

5.1

5.1.1

?

CN1 50

가

▶ 17 가 CN1 3~9 7

▶ 8 가 CN1 (41,42), (43,44), (47,48)

3

가

가

CN1

가

CN1 50

▶ (DI#1) ~ (DI#7) (Digital Input)

▶ (DO#1) ~ (DO#3) (Digital Output)

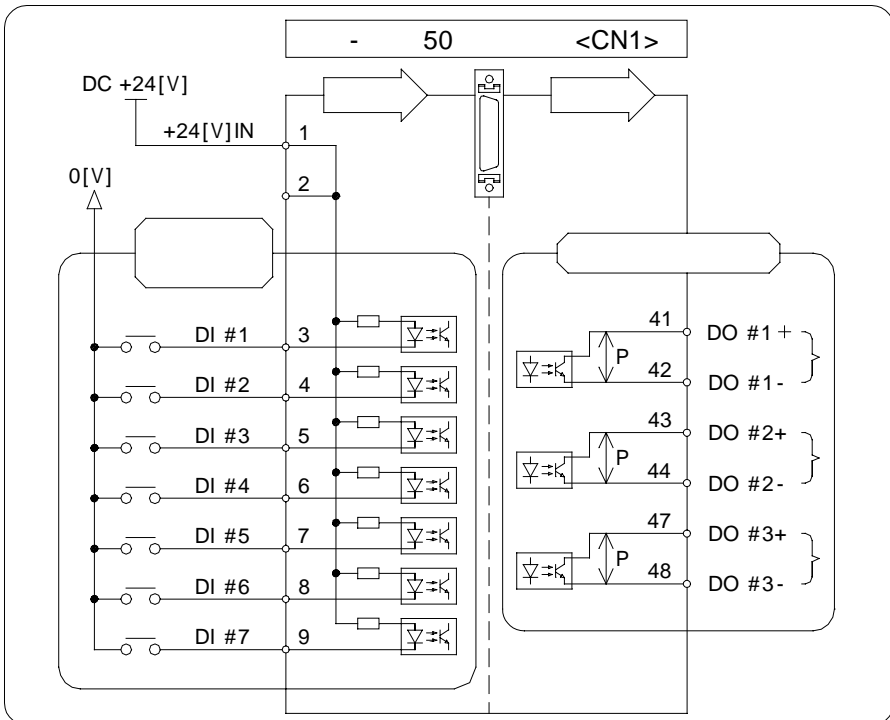

5.1.2

17가

</SV-ON> -ON	ON OFF	가	All 4.1.1
</A-RST>			All 7.10.10
</G-SEL>	ON OFF	2 . 2가	All 6.6.5
</P-TL>	가 ON	[Pr-4.03]	All 5.4.4
</N-TL>	가 ON	[Pr-4.04]	All
<P-OT>	가	가	P, S, C 7.1.3
<N-OT>	가	가	P, S, C
</P-CON> P	PI	P	P, S, C 6.6.3
</C-SEL>			5.6
</C-DIR> </C-SP1> </C-SP2> </C-SP3>		</C-DIR> </C-SP1 ~ /C-SP3> 가 [Pr-2.05 ~ Pr-2.11]	C 5.5
</Z-CLP>		[Pr-5.04]	S 5.3.4
</INHIB>	가 ON		P 5.2.8
</ABS-DT>	가 ON	EA, EB	P 7.9.5

5.1.3

8가

/P-COM (+, -) ()	가 ON [Pr-5.00]	P	5.2.9
/NEAR (+, -) ()	가 ON [Pr-5.01]	P	
/V-COM (+, -) ()	[Pr-5.02] 가 ON	P, S, C	5.3.5
/TG-ON (+, -) ()	가 [Pr-5.03] ON	All	5.3.6
/T-LMT (+, -) ()	가 ON	All	5.4.4
/V-LMT (+, -) ()	가 ON	All	5.3.7
BK (+, -) ()		All	7.2
/WARN (+, -) ()	가 ON	All	8.2.1

 <input data-bbox="134 997 224 1061" type="text"/>	▶ <>
	▶ ex) </SV-ON>, </P-COM>

5.1.4

CN1

	8	7	6	5	4	3	2	1	0
		DI#7	DI#6	DI#5	DI#4	DI#3	DI#2	DI#1	
CN1		9	8	7	6	5	4	3	

- ▶ '0' '1~8'
- ▶ CN1 5 가 '3'
- ▶ '0'
- ▶ 가 ON '8'
- 7- 가

	7-				
		000	<u>0</u>	<u>0</u>	<u>0</u>
1	Pr-0.05	</P-CON> 4	<N-OT> 3	<P-OT> 2	</SV-ON> 1
2	Pr-0.06	</C-SEL>	</P-TL> 7	</N-TL> 6	</A-RST> 5
3	Pr-0.07	</C-SP3>	</C-SP2>	</C-SP1>	</C-DIR>
4	Pr-0.08	Reserved	</G-SEL>	</INHIB>	</Z-CLP>
5	Pr-0.09	Reserved	Reserved	Reserved	</ABS-DT>

Pr-0.05	[Pr-0.05]	'7'
8.8.78.8.8	</P-CON> DI#7	CN1

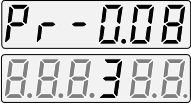
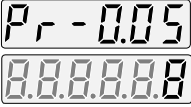





	[Pr-0.08] '3' </G-SEL> CN1 DI#3
	[Pr-0.05] '8' </SV-ON> '8' ON 가 가

5.1.5

CN1

	3	2	1	0
	DO#3	DO#2	DO#1	
CN1	47, 48	43, 44	41, 42	

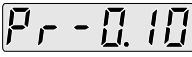
▶ '0'
7-
가

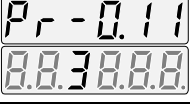

	7-				
					
1		</V-COM>	</BK> 3	</TG-ON> 2	</P-COM> 1
2		</WARN>	</NEAR>	</V-LMT>	</T-LMT>

	[Pr-0.10] '1' </P-COM> CN1 DO#1
	[Pr-0.11] '3' </WARN> CN1 DO#3

	▶
---	---

5.1.6

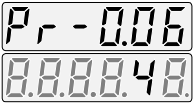
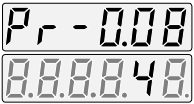
CN1

	<p>[Pr-0.06] '4'</p> <p></N-TL> CN1</p> <p>DI#4</p>
	<p>[Pr-0.08] '4'</p> <p></INHIB> CN1</p> <p>DI#4</p>
<p>2 가 가 가</p>	
	<p>(Pin) 가</p> <p>2 가 가 CN1</p>

	<p>▶ 7.11 가</p>
---	-----------------

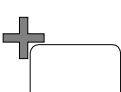
	<p>▶ E-STOP () CN1</p> <p>▶ SALM +, - () CN1</p>
---	--

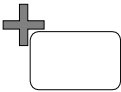
	<p>▶ , 가</p>
---	--------------

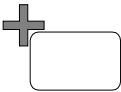
	<p>▶</p> <p>▶ 8</p>
---	---------------------

5.2

5.2.1

가

PULS, SIGN

PCLR

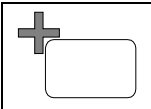
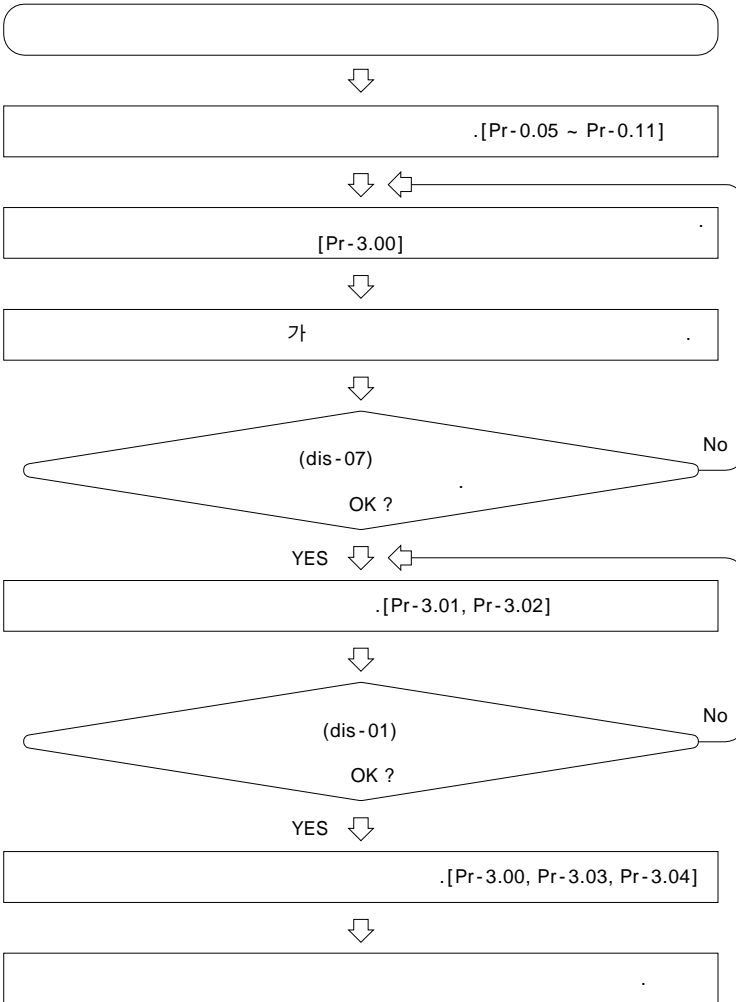

▶ (CSD3- BX P, CSD3- BX)

5.2.2

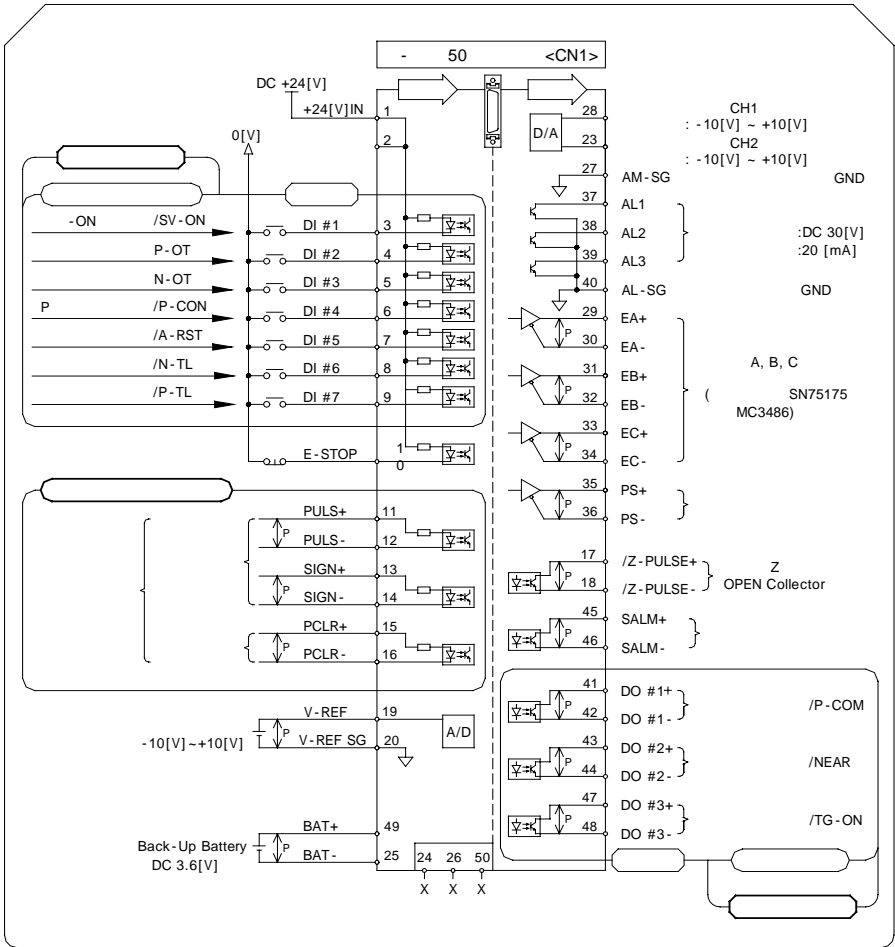

5.2.3

1. CN1 6 3가 .
 ▶ 가 가 .
 ▶ '0' PCLR 가 . PCLR
- 5.2.7

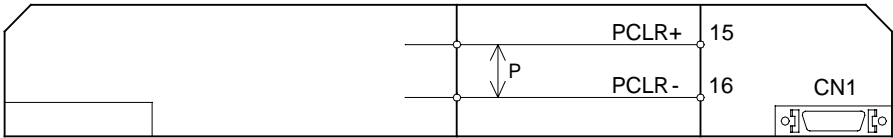
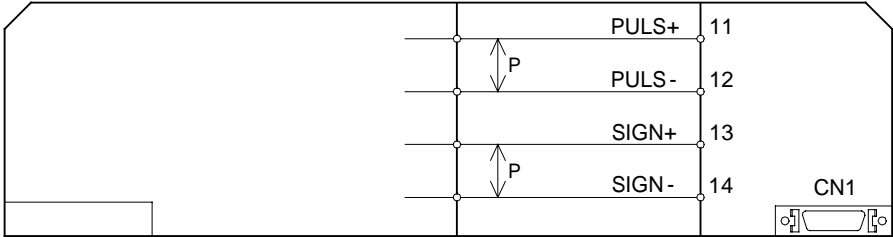

27가

.1 : (900[kpps]

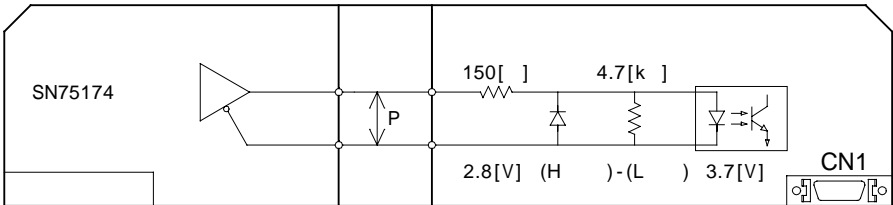

.2 : (300[kpps]

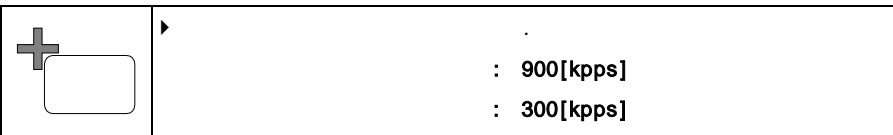
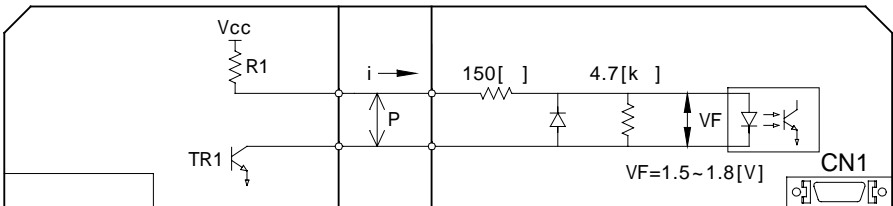

2.

low TR1 ON high
 TR1 OFF
 (Pull Up) R1 이가 7[mA]~15[mA] 가

Vcc	24[V] ± 5[%]	12[V] ± 5[%]	5[V] ± 5[%]
R1	2.2[kΩ]	1[kΩ]	180[Ω]

Vcc 24[V]

▶ CN1 12, 14, 16 low (0.6[V])
 R1 가
 , 가 Vcc 24[V] R1
 2.2[KΩ]

3.

Pr - 3.00 8.8.8.8.00

0	
1	

P -OFF > >

900[kpps].
 300[kpps]

▶ “E.OvPUL”

5.2.4

가
가

Pr - 3.00		8.8.8.8.0			
CW + CCW	PULS →	"L"	PULS →	0	
	SIGN →	[Square Wave]	SIGN →	"L"	
+	PULS →	[Square Wave]	PULS →	2	
	SIGN →	"H"	SIGN →	"L"	
A + B	PULS →	[Square Wave]	90	1	4
			90	2	5
			90	4	6
CW + CCW	PULS →	"H"	PULS →	1	
	SIGN →	[Square Wave]	SIGN →	"H"	
+	PULS →	[Square Wave]	PULS →	3	
	SIGN →	"L"	SIGN →	"H"	
	P		-OFF >	>	

+	▶ 7.11
---	--------

5.2.5

CW + CCW				
	$t1, t2 \quad 0.1[\mu s]$	$\tau \quad 1.1[\mu s]$		
	$t3 > 3[\mu s]$	$\tau/T \times 100 \quad 50[\%]$		
+				900[Kpps] : : 300[Kpps]
	$t1, t2, t3, t7 \quad 0.1[\mu s]$	$t4, t5, t6 > 3[\mu s]$	$\tau \quad 1.1[\mu s]$	
90 A + B				
	$t1, t2 \quad 0.1[\mu s]$	$\tau \quad 1.1[\mu s]$	$\tau/T \times 100 \quad 50[\%]$	

5.2.6

1.

- ▶ 1 2048 가 2048 2048
1 1000 ()
1 ? ->
- ▶ (1)가 15[mm] (Ball screw)
가 2048
15[mm] 1500
1 (15[mm]) ? ->
- ▶ 360 2048
가
- ▶ 가
- ▶

2.

	4.2.3

3.

▶

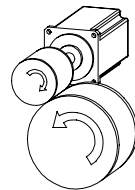
<div style="border: 1px solid black; width: 100px; height: 40px; margin: 0 auto;"></div>	$=$	<div style="display: flex; justify-content: center; align-items: center; gap: 10px;"> <div style="border: 1px solid black; width: 200px; height: 20px; margin-bottom: 5px;"></div> <div style="border: 1px solid black; width: 200px; height: 20px; margin-bottom: 5px;"></div> </div> <div style="display: flex; justify-content: center; align-items: center; gap: 10px;"> →  </div>
▶ 5 가 1 '5'		
▶ 1 가 5 '0.2'		

5. 가 2 (Belt)

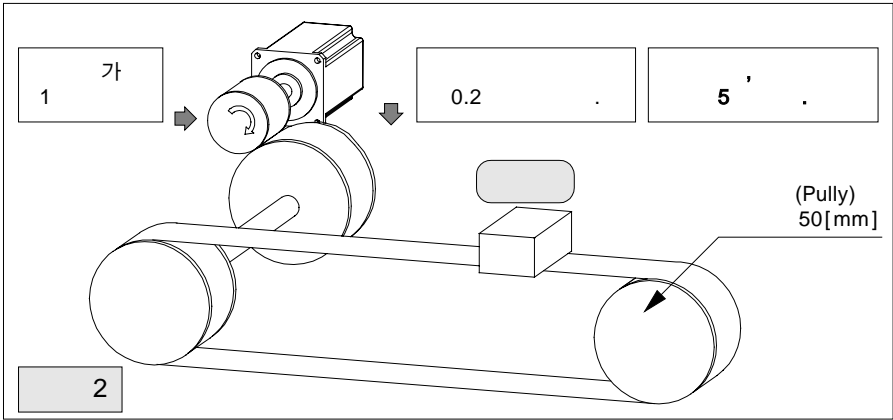

▶ 1

▶ 1 100[um] 가
▶ 2048[pulse] 가 '5' 가

Pr - 3.01		X	
, 2048[pulse] X 5		10240	
Pr - 3.02	$\frac{1}{1} = \frac{3.14 \times 50[\text{mm}]}{100[\text{um}]} = 1570$		
1570	가	1	
▶	1	100[um]가	
▶			
Pr - 3.01		10240	1024
Pr - 3.02		= 1570	= 157

6.

3

가 (Turn table)

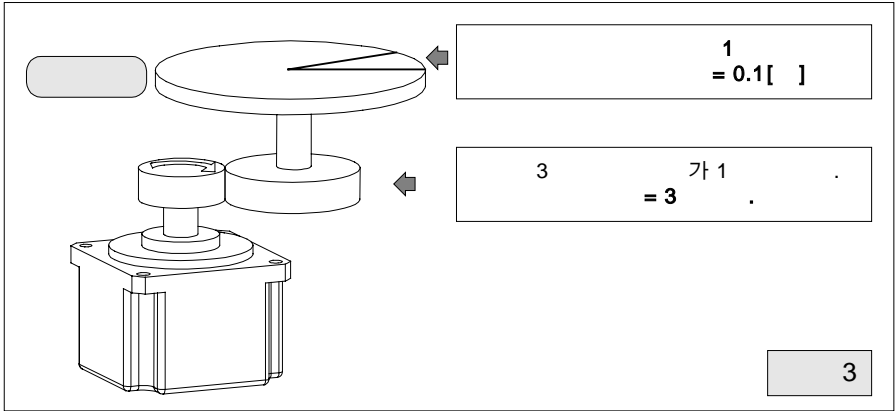

- ▶ 1 0.1° 가
- ▶ 2048[pulse] 가 '3' 가

<div style="border: 1px solid black; padding: 2px; display: inline-block;">Pr - 3.01</div>	<div style="border: 1px solid black; width: 80%; margin: 0 auto; display: flex; justify-content: space-around; align-items: center;"> X </div>
	, 2048[pulse] X 3 6144
<div style="border: 1px solid black; padding: 2px; display: inline-block;">Pr - 3.02</div>	$\frac{1}{1} = \frac{360 [\text{ }]}{0.1 [\text{ }]} = 3600$
3600 가 1	
▶ , 1 0.1 []가	
▶	
▶	

<div style="border: 1px solid black; padding: 5px; display: inline-block;">+</div>	▶ 4.2.3 2 가 ▶
--	----------------------------

7.

Pr - 3.01			()	
				-OFF > >
0~65535		[pulse]		P
[]			X	[]

Pr - 3.02			()	
				-OFF > >
0~65535		[pulse]		P
() 1				

+	▶ 4.2 Type
	▶ (Run-09)
	▶ -ON

8.

▶ [1] x [] x 4 [Pr-3.02]
▶ 가 가 ,

1 / [(1) X () X 4] .
[Pr-3.02]
▶ 1 . (=
.)
▶ [Pr-3.02] 4 ,

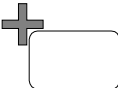
	▶ CSD3	±1[pulse]	
	▶ 1	[Pr-3.01]=5000	
	▶ [Pr-3.02]	5000 X 4=20000	
	▶ 20000 = 0.5[um]		10[mm] /

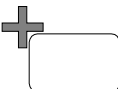
	▶		
	▶ 7.2	()

5.2.7

(PCLR)

가

가 '0'

가

(PCLR)

CN1 (15, 16)

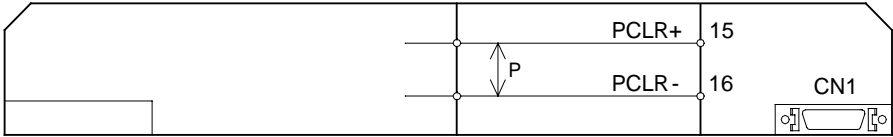

가 '0'

(Trigger)



Pr - 3.00 8.8.08.88		PCLR ()	
0	H H	'0'	"H"
1	(Rising edge)		
2	L L	'0'	"L"
3	(Falling edge)		
	P		-OFF > >

5.2.8

</INHIB>

</INHIB>

ON

가

가
</INHIB>

</INHIB>

가 ON/OFF

▶ Td 10[msec]

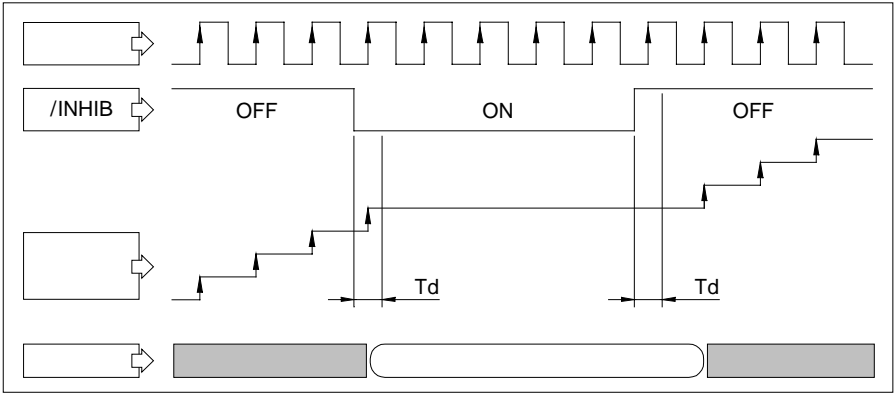

</INHIB>

. </INHIB>
</INHIB>

5.1

	▶ 5.1.4	가 '8'
	▶	</INHIB> '8' (Locked)

5.2.9

</P-COM>, </NEAR>

</NEAR>

1.

</P-COM>

</P-COM>



가

가

</P-COM>

2.



</P-COM>

()

Pr - 5.00				
				>
0~250	10	[pulse]		P
가		가	</P-COM> 가	

3.

</NEAR>

</NEAR>



가

가

</NEAR>

4.



</NEAR>

()

Pr - 5.01				
				>
0~250	20	[pulse]		P
가		가	</NEAR> 가	

5.

</NEAR>

</P-COM>

가

[Pr-5.00] [Pr-5.01]

</P-COM>

</NEAR>

</P-COM> 가

1

LED가

</NEAR>

6.

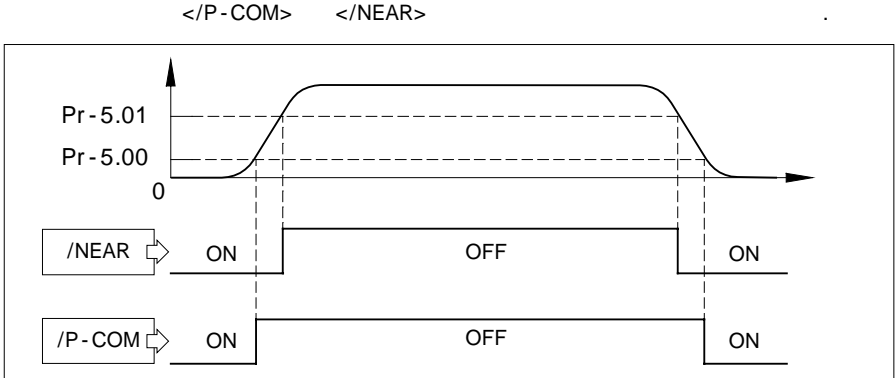

</P-COM> </NEAR> ON
 가 100[pps]

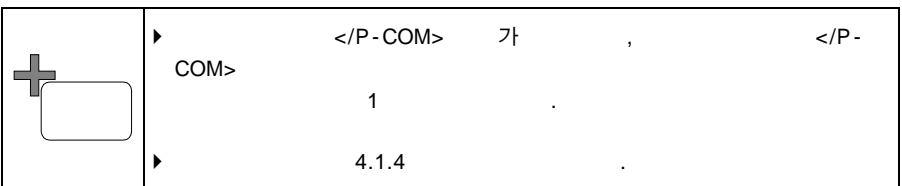
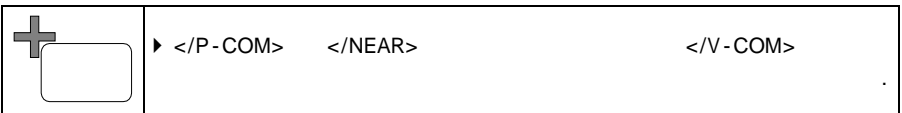
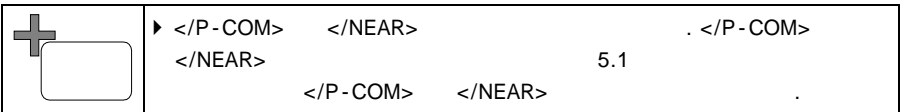
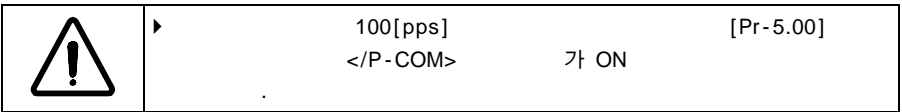

5.2.10

Pr - 5.09				
				>
0~65535	20480	[pulse]		P
▶ 가				(E.PoSEr)

5.2.11 Timing diagram

(Timing diagram)

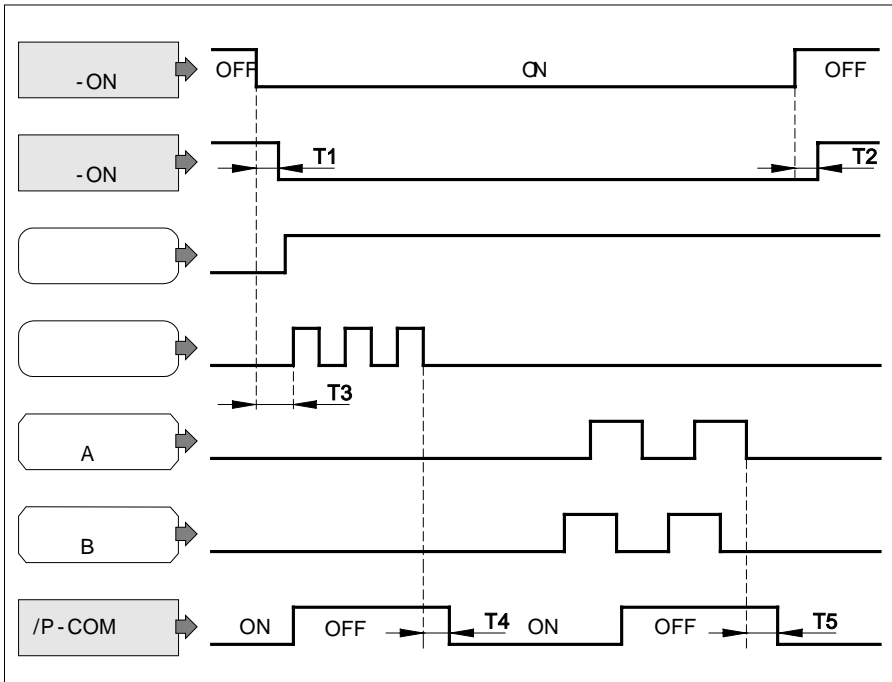



T1	T2	T3	T4	T5
40[ms]	6[ms]	40[ms]	2[ms]	

5.3

5.3.1

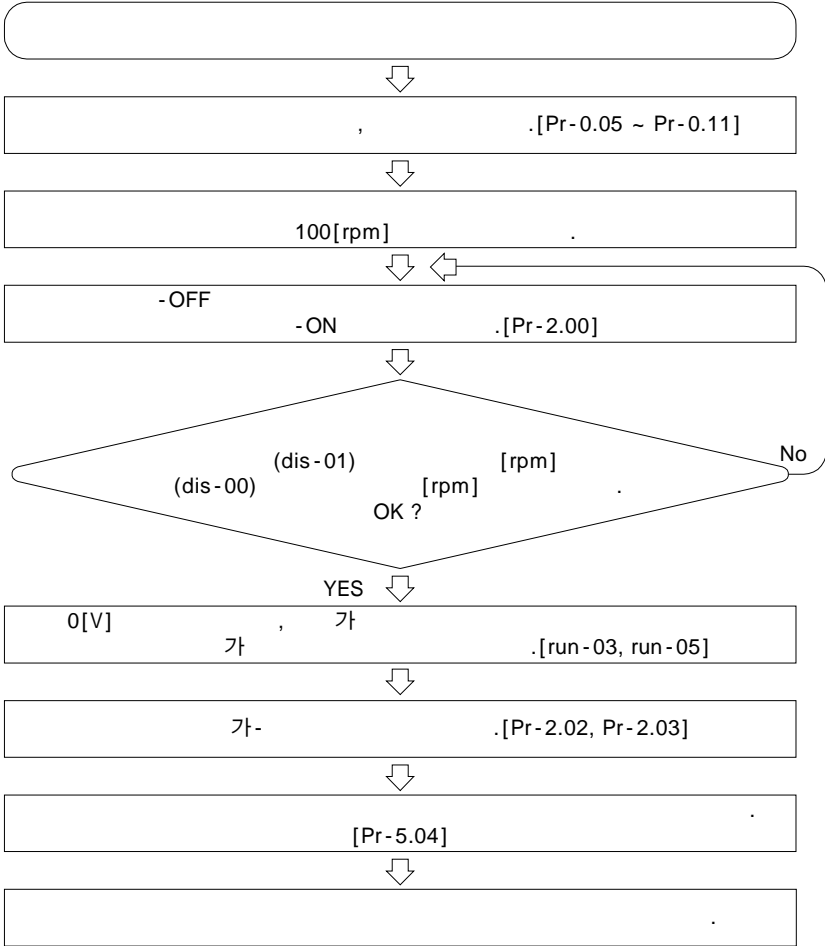
가



 	(Position-Control-Only) CSD3- BX P
--	------------------------------------

5.3.2

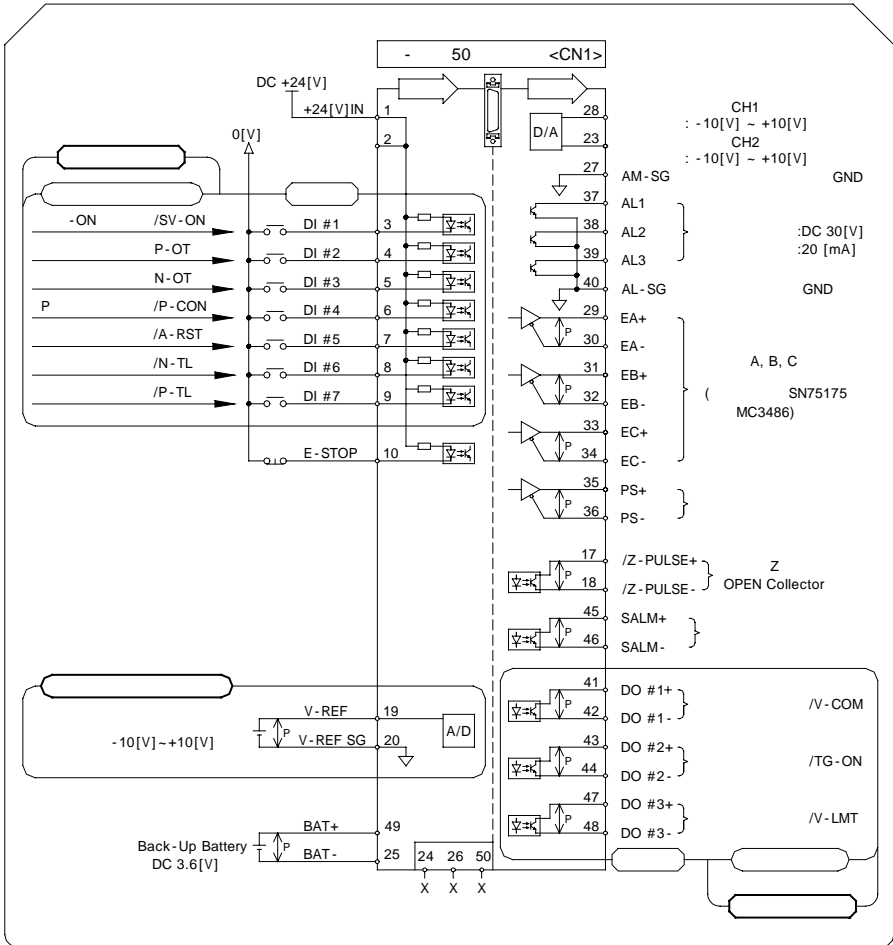

5.3.3

1.

CN1 19, 20

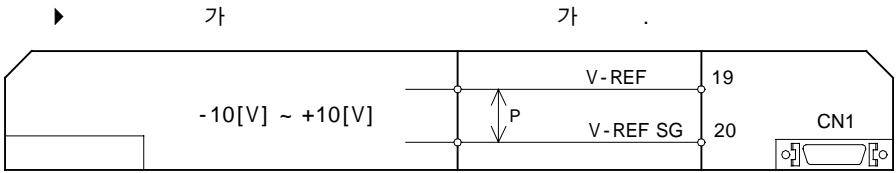

2.

Pr - 2.00				
				>
10.0~2000.0	500.0	[rpm/V]		S
1[V]		[rpm]		
▶ 7.6				

$$\begin{matrix} \text{[rpm]} \\ 10[\text{V}] \end{matrix} = \begin{matrix} \text{Pr - 2.00} \\ 5000[\text{rpm}] \end{matrix} \begin{matrix} \text{[rpm/V]} \\ 6[\text{V}] \end{matrix} \times \begin{matrix} \text{X} \\ 3000[\text{rpm}] \end{matrix} \begin{matrix} \text{[V]} \\ 10[\text{V}] \end{matrix}$$

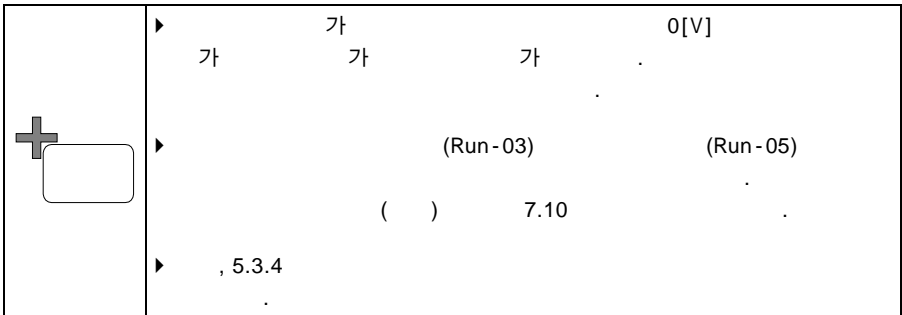
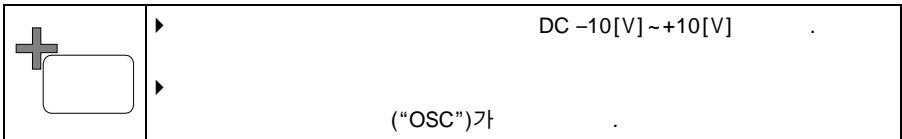

5.3.4

</Z-CLP>

0[V]
가

</Z-CLP>
5.1

</Z-CLP>
</Z-CLP>

Pr-5.04				
				>
0~5000	0	[rpm]		S
가				

CN1
[Pr-5.04]

ON/OFF

가

, 5.1.4

'8'

'0'

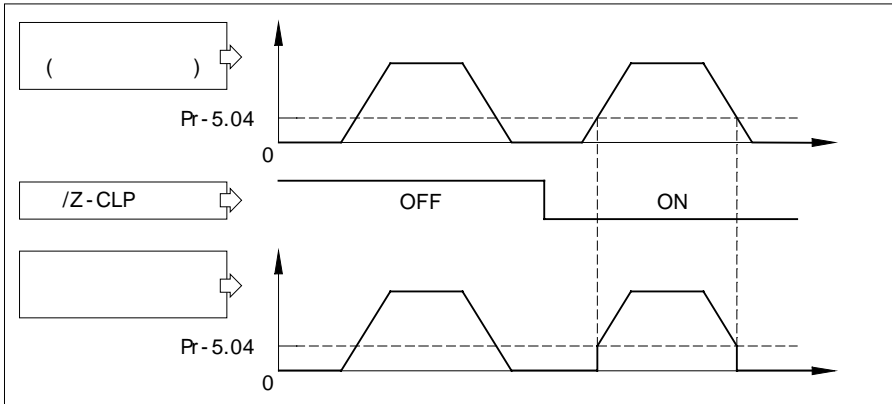

	▶ /Z-CLP	Pr-5.04 0
	▶ /Z-CLP	
	▶ 가	Pr-2.02
	Pr-2.03 가 '0'	

5.3.6

</TG-ON>

가

</TG-ON>
5.1

. </TG-ON>
</TG-ON>

Pr-5.03				
				>
1~5000	20	[rpm]		ALL
가			</TG-ON>	

</TG-ON>

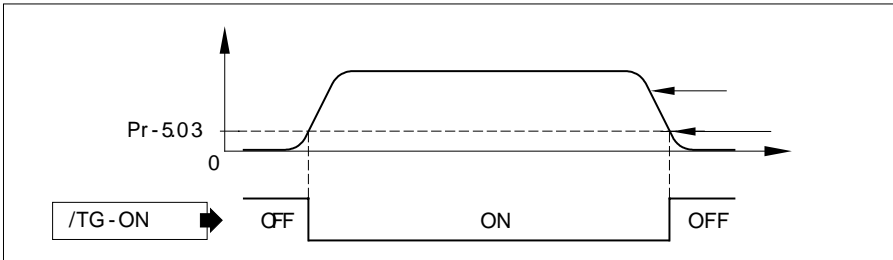

+	▶	Pr-5.03 </TG-ON> 가
---	---	-----------------------

5.3.7

</V-LMT>

5000[rpm]

Pr-2.12				
				-OFF > >
1~5000	5000	[rpm]		ALL

[Pr-2.12] 1000[rpm] 1000[rpm] 1500[rpm]

</V-LMT> 5.1 </V-LMT> </V-LMT> </V-LMT> </V-LMT> </V-LMT> 가

</V-LMT> ON

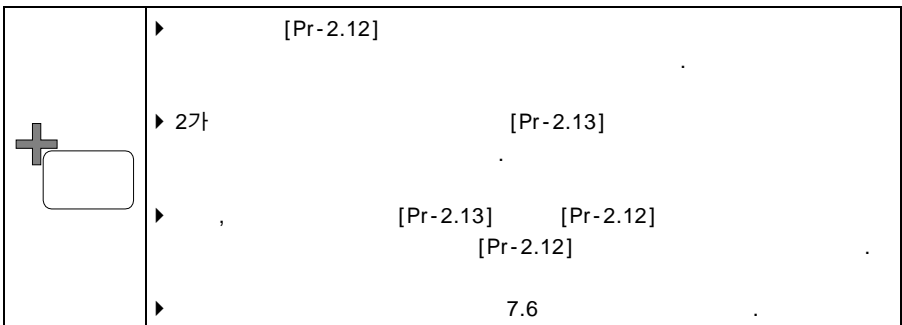
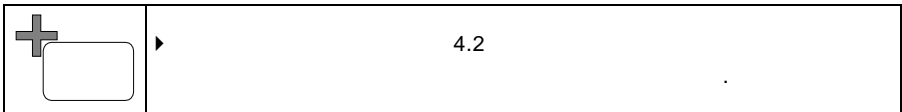

5.4

5.4.1

가

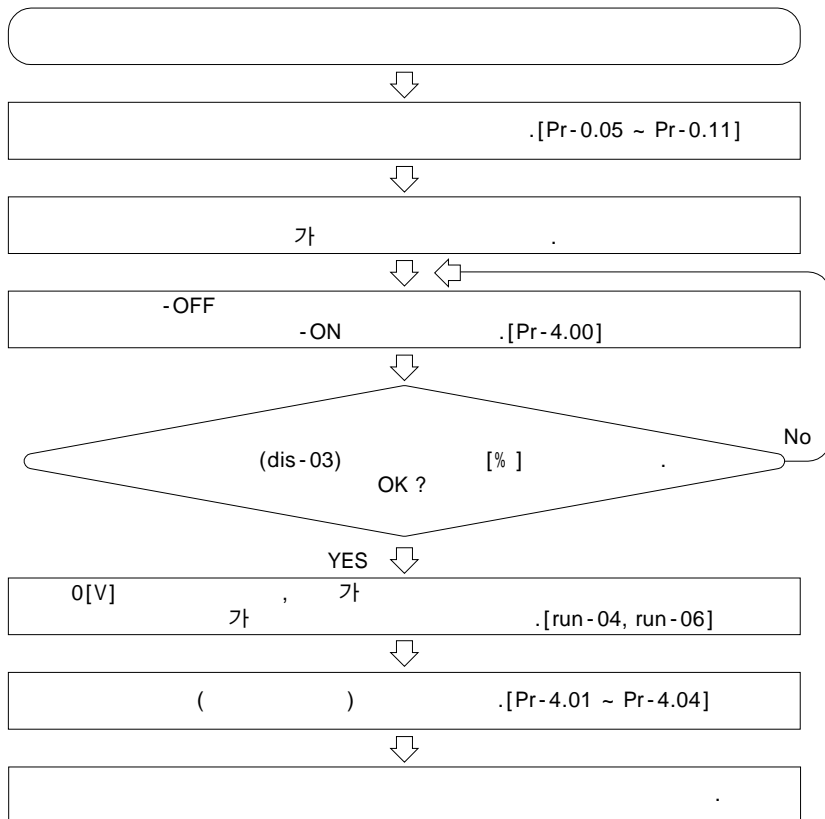

(Position-Control-Only) CSD3- BX P

5.4.2

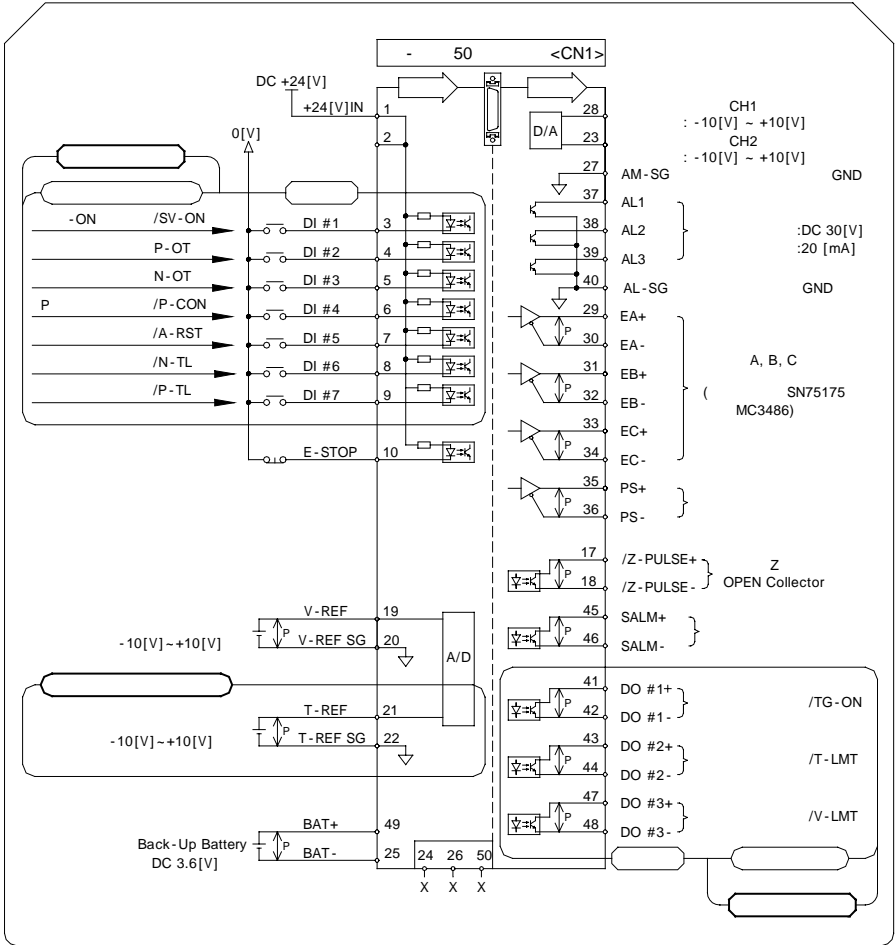

5.4.3

1.

CN1 21, 22

가 가

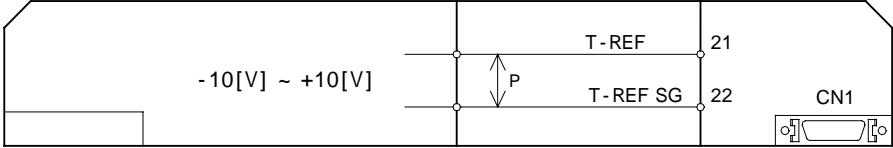

2.

Pr - 4.00				
				>
0.0~100.0	33.3	[% /V]		t
1[V]		[%]		

$$[\text{Nm}] = \frac{\text{Pr - 4.00} \times [\text{V}] \times \text{[]}}{100}$$

(9[V] 3[V] 300[%] 100[%] 가)

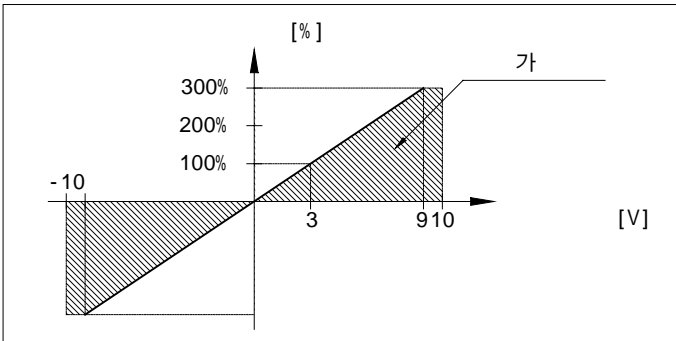

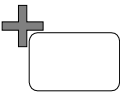
	▶	DC -10[V] ~ +10[V]	.
	▶		
	▶	10-turn ()	가
	▶		
		(“OTC”)가	.

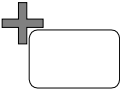
	▶	가	가	가	0[V]
	▶	가	가	가	.
	▶		(Run-04)		(Run-06)
	▶		()	7.10	.

5.4.4

</T-LMT>

()

1.

2.

가

3.

Pr - 4.01			()	
				>
0~300	300	[%]		ALL
[%]				

Pr - 4.02			()	
				>
0~300	300	[%]		ALL
[%]				

4.

Pr - 4.03			</P-TL>	
				>
0~300	100	[%]		ALL
</P-TL> ON [%]				

Pr - 4.04			</N-TL>	
				>
0~300	100	[%]		ALL
</N-TL> ON [%]				

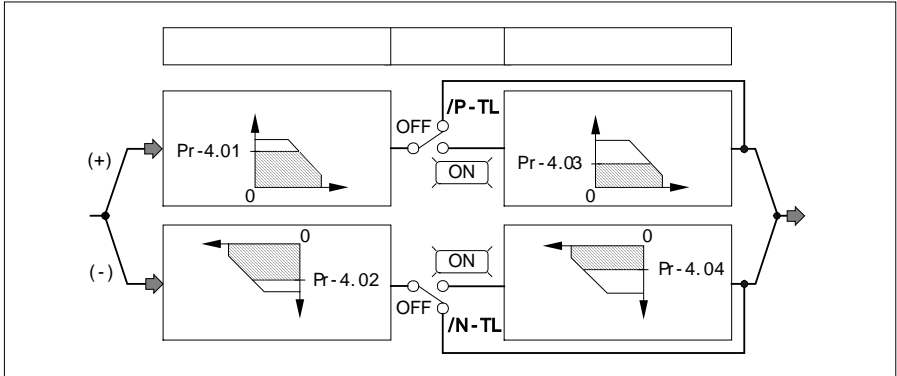

5.

</P-TL> </N-TL>
5.1

. </P-TL> </N-TL>
</P-TL> </N-TL>

</P-TL>

</N-TL>

[Pr-4.01]

[Pr-4.02]

</P-TL>

</N-TL>

6.

)

가

(

, [Pr-4.01] [Pr-4.02]

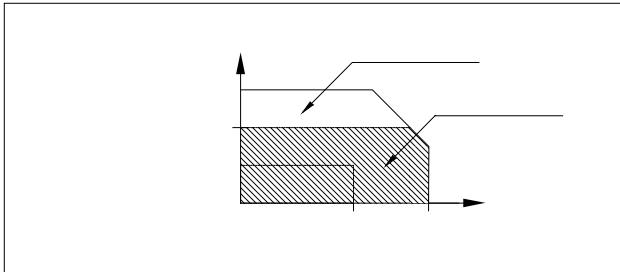

	<p>가 300[%] [Pr-4.01] [Pr-4.02]</p>
--	---

7.



7.1.3

Pr-4.05			<P-OT>, <N-OT>	
				>
0~300	300	[%]		ALL
가				

+		
		가

8.

</T-LMT>

가 가 </T-LMT>

</T-LMT> 5.1 </T-LMT> </T-LMT>

</T-LMT> ON

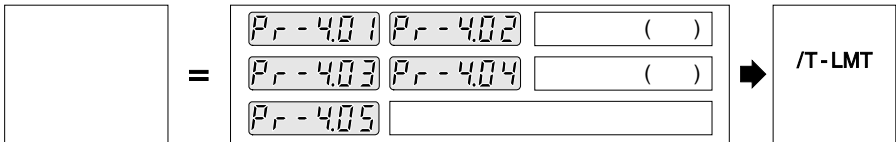



+		
		</P-OT> </N-OT>
		[Pr-4.05]
		가 가

5.5

5.5.1

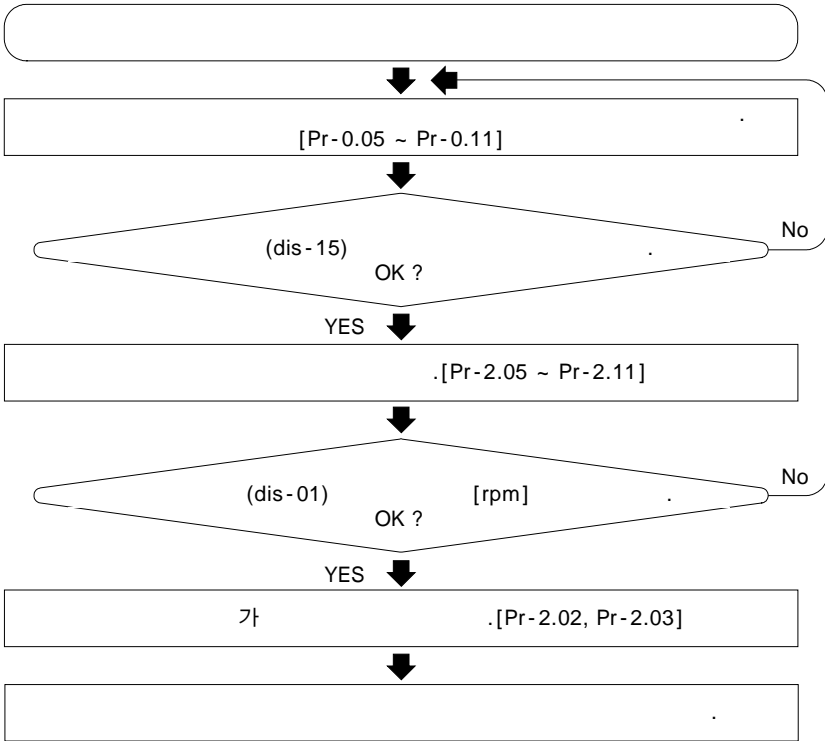
가
가



 <input type="text"/>	CSD3- BX P	(Position -Control -Only)
---	------------	---------------------------

5.5.2

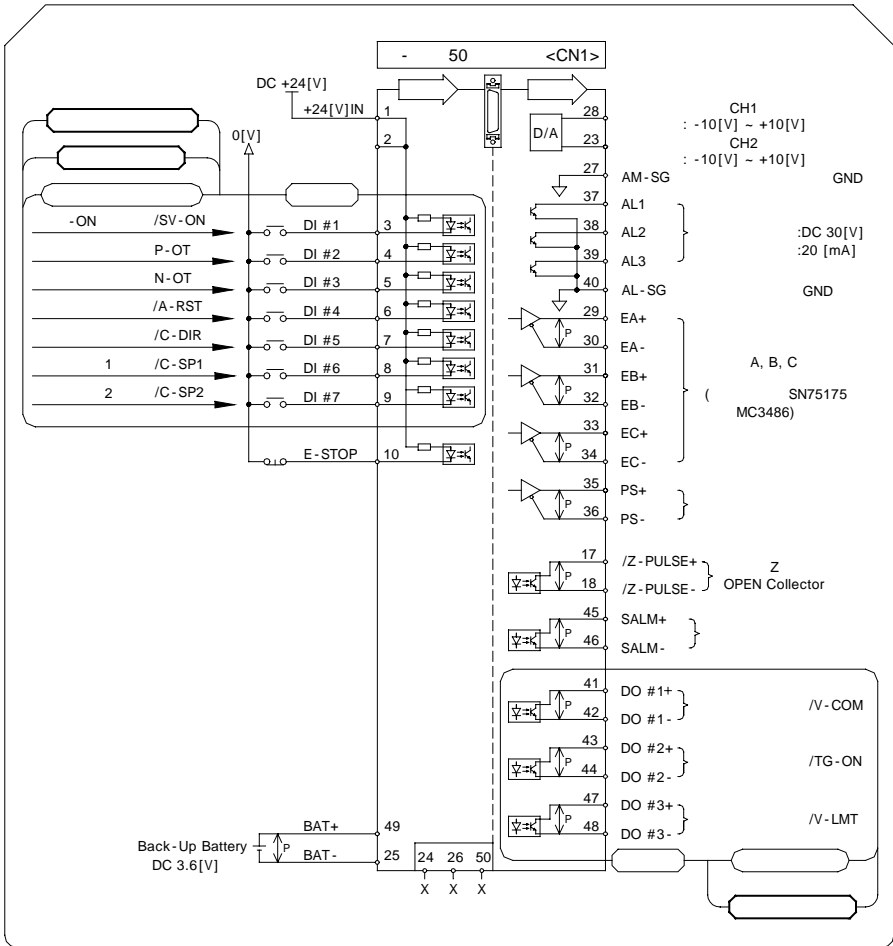

5.5.3

4가

/C-DIR

/C-SP1

/C-SP2

/C-SP3

가

가

1. </C-DIR>

ON

</C-DIR> 가 OFF



</C-DIR>		
1	OFF	0
2	ON	1

2. </C-SP1>, </C-SP2>, </C-SP3>

3가

8가

가

		</C-SP3>	</C-SP2>	</C-SP1>
	0[rpm]	0	0	0
1	Pr-2.05 880100	0	0	1
2	Pr-2.06 880200	0	1	0
3	Pr-2.07 880300	0	1	1
4	Pr-2.08 880400	1	0	0
5	Pr-2.09 880500	1	0	1
6	Pr-2.10 880600	1	1	0
7	Pr-2.11 880700	1	1	1
	  <input type="text"/> [rpm]			
-5000~5000	100 ~700	[rpm]	C	>

</C-DIR>, </C-SP1>, </C-SP2>, </C-SP3>

5.1

▶ </C-DIR>

▶ , </C-SP1>, </C-SP2>, </C-SP3> 3가
</C-SP1> 17가 </C-SP1>, </C-SP2> 27가

▶ 5.1
'8'

3.

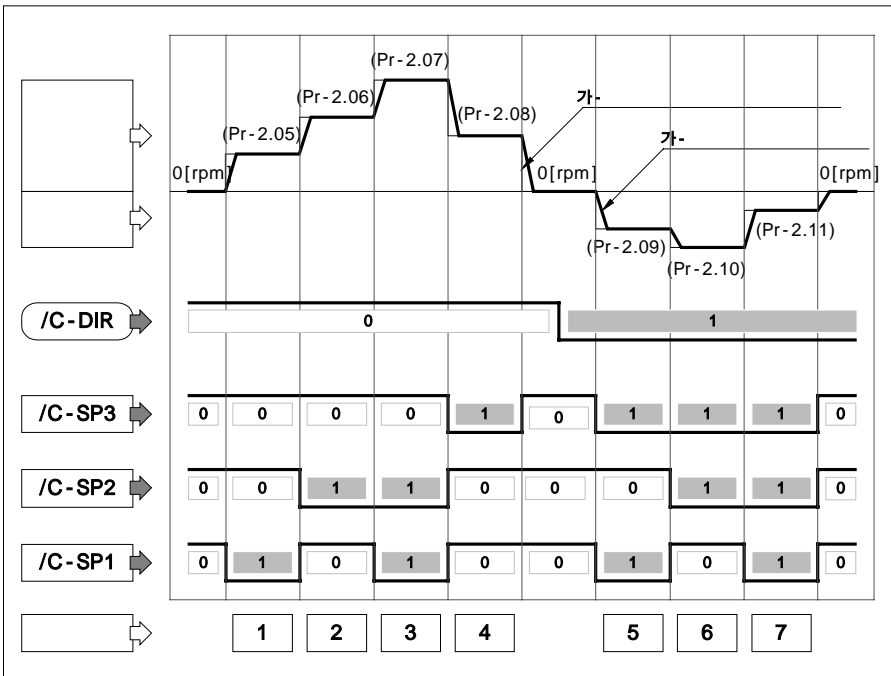

▶ 가-

▶ 가- 7.5

5.6 </C-SEL>

2가

1.

4.2.2

2. 2가

</C-SEL>

</C-SEL>

</C-SEL>

5.1

</C-SEL>

</C-SEL>

</C-SEL>

</C-SEL>

[Pr-0.00]		</C-SEL>	
		</C-SEL> = OFF	</C-SEL> = ON
	.		
	.		
	.		
	.		
	.		
	.		

가

</C-SEL>

-ON
가

	</C-SEL> , [Pr-0.00] </C-SEL> "PIN"
--	--

3.

가 가
</C-SEL>

</C-SEL>

	1. </P-COM> = ON
	1. </V-COM> = ON 2. </TG-ON> = OFF
	1. </TG-ON> = OFF
	1. </C-SP1> ~ </C-SP3> = OFF 2. </TG-ON> = OFF

2가

, 2가

</C-SEL>

 <input style="width: 60px; height: 20px;" type="text"/>	<p>▶</p> <p>▶ 가- [Pr-2.02] [Pr-2.03], S-</p> <p>[Pr-2.04]</p> <p>▶</p>
--	--

6.1	122
6.1.1	122
6.1.2	(Gain)	123
6.1.3	124
6.2	125
6.3	127
6.3.1	127
6.3.2	-	127
6.3.3	-	128
6.4	129
6.4.1	129
6.4.2	130
6.5 (, ,)	132
6.5.1	132
6.5.2	134
6.5.3	136
6.6	tip	138
6.6.1	(Feedforward)	138
6.6.2	(bias)	139
6.6.3	P/PI	140
6.6.4	144
6.6.5	</G-SEL>	146

6.1

6.1.1

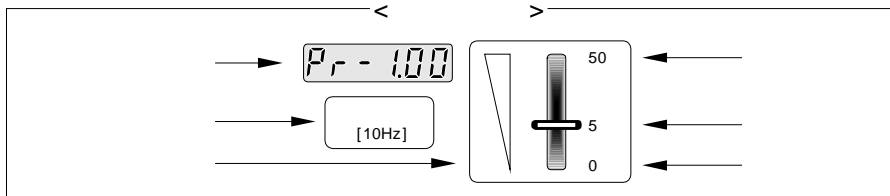

6.1.2 (Gain)

가

(Equalizer)

()

가

(Tuning)

1. 가 가

?

1

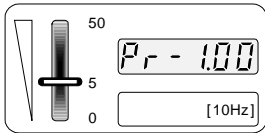
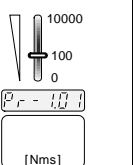
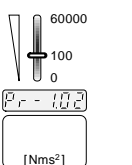
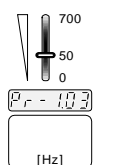
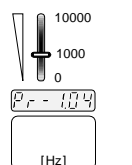
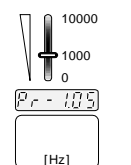
< > (Bandwidth)				
5 가				
(Bandwidth)				
< > 가 5 가				
				

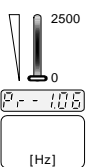
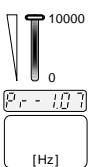
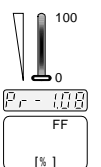
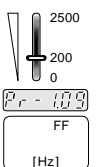
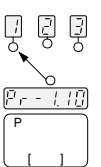
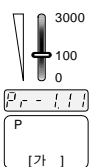
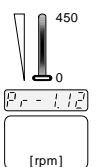
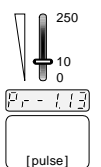
< > 가 4 가				< > 가 4 가			
							

1

13가

2. 가

가

6.1.3

1. ?

	▶ (Rotor)
	▶ (Rotor) 3 [gf.cm.s ²] 30 [gf.cm.s ²]
	▶ 10[]가 (Rotor) (Inertia)

2.

[] '1.00' 1[]

▶

3.

Pr-0.04				
				>
0.00~60.00	1.00	[]		ALL
▶ 7.10.3 -				

4.

가
2가

2가	

6.2

(, ,)



1	▶		1
	▶		
	▶		

2	▶		1
	▶		
	▶		

3	▶		
	▶		

+	▶		
□			

+	▶	7.6	
□	▶	5.4	

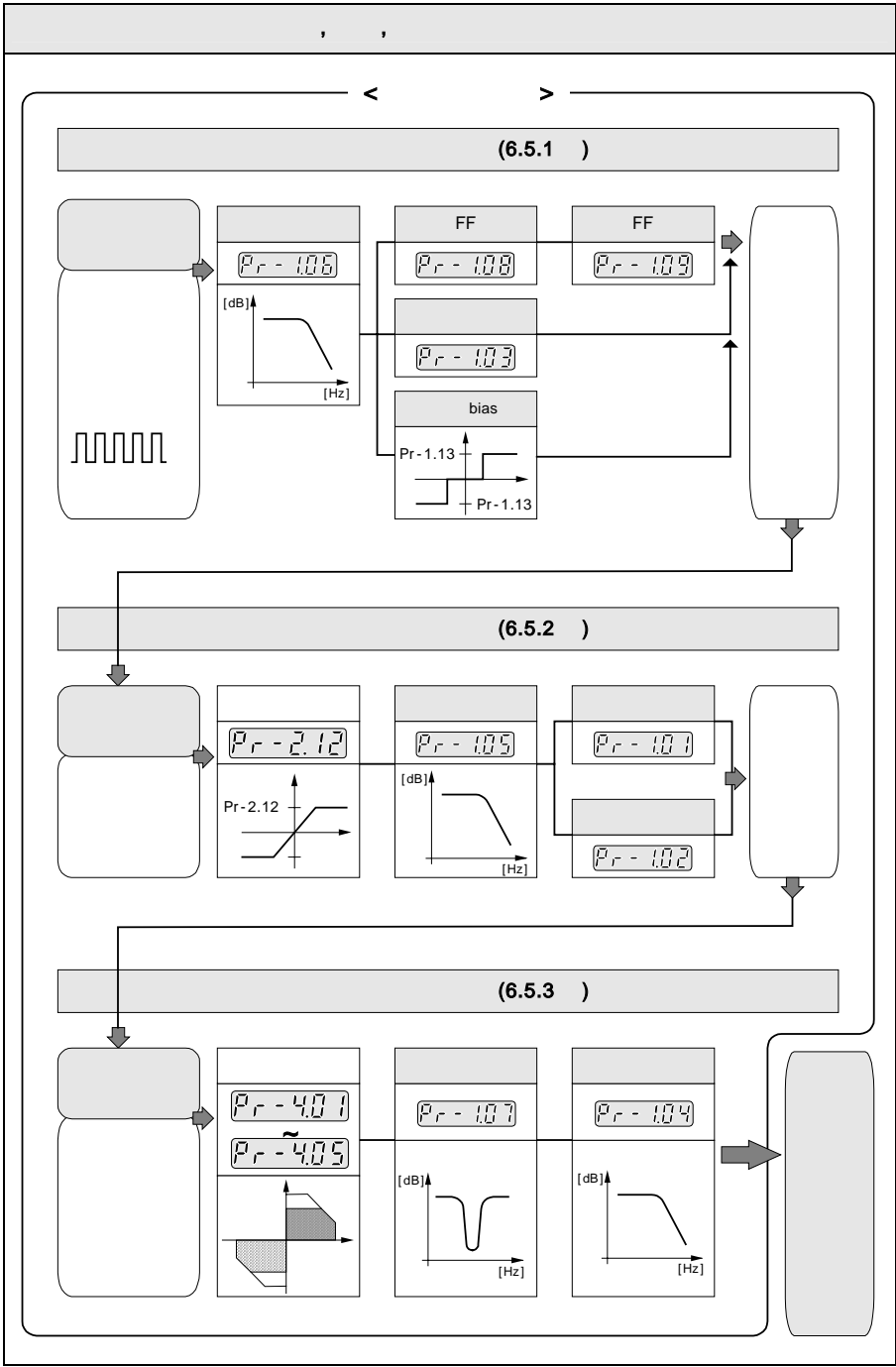

6.3

6.3.1

2가

- ▶ - (Off-line)
- ▶ - (On-line)

6.3.2

1.

- ▶ , , 2가
- ▶

2. ()

- ▶ - 7.10.3

3.

- ▶ - [Pr-0.04]
- ▶ 2가

- ▶ , ()
- ▶ 가

가 , [Pr-1.07] 가

가

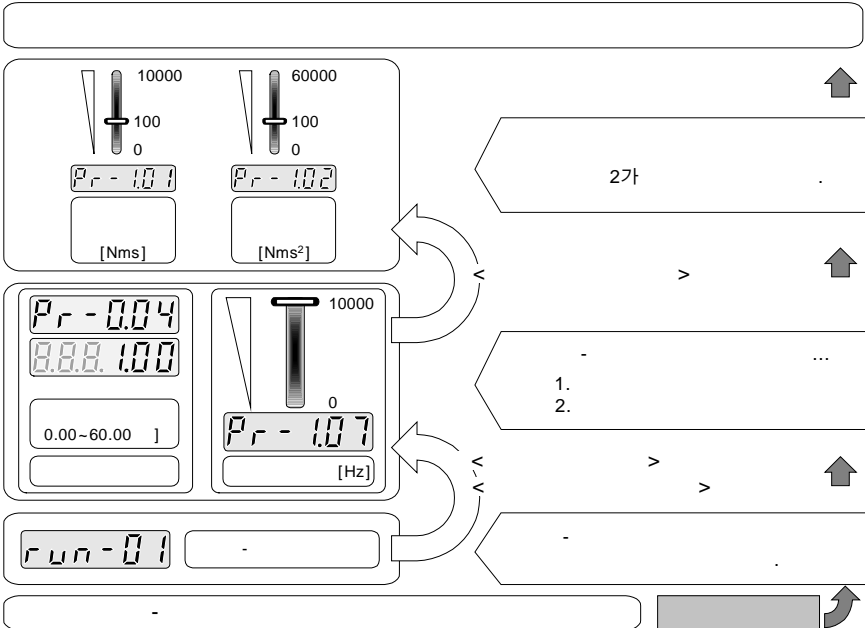

6.4

6.4.1

The diagram illustrates a sequence of five steps for configuring a device, each involving a digital display, a potentiometer, and a unit label. The steps are connected by downward arrows.

Step 1: The display shows $Pr-0.04$ and 888.100 . Below the display is a range $0.00-60.00 []$ and a potentiometer set to 50. The unit label is $[10Hz]$.

Step 2: Five potentiometers are shown with their respective scales and values:

- Potentiometer 1: Scale 0-10000, value 100. Label: $Pr-1.01$ [Nms]
- Potentiometer 2: Scale 0-60000, value 100. Label: $Pr-1.02$ [Nms²]
- Potentiometer 3: Scale 0-700, value 50. Label: $Pr-1.03$ [Hz]
- Potentiometer 4: Scale 0-10000, value 1000. Label: $Pr-1.04$ [Hz]
- Potentiometer 5: Scale 0-10000, value 1000. Label: $Pr-1.05$ [Hz]

Step 3: Four potentiometers are shown with their respective scales and values:

- Potentiometer 1: Scale 0-2500, value 0. Label: $Pr-1.06$ [Hz]
- Potentiometer 2: Scale 0-10000, value 0. Label: $Pr-1.07$ [Hz]
- Potentiometer 3: Scale 0-100, value 0. Label: $Pr-1.08$ [%]
- Potentiometer 4: Scale 0-2500, value 200. Label: $Pr-1.09$ [Hz]

Step 4: Four potentiometers are shown with their respective scales and values:

- Potentiometer 1: Scale 0-3, value 1. Label: $Pr-1.10$ [P]
- Potentiometer 2: Scale 0-3000, value 100. Label: $Pr-1.11$ [P]
- Potentiometer 3: Scale 0-250, value 10. Label: $Pr-1.13$ [pulse]
- Potentiometer 4: Scale 0-450, value 0. Label: $Pr-1.12$ [rpm]

Step 5: A large empty box.

6.4.2

5가

1	▶ , -	[Pr-0.04]
2	▶	
3	▶	
-		

가

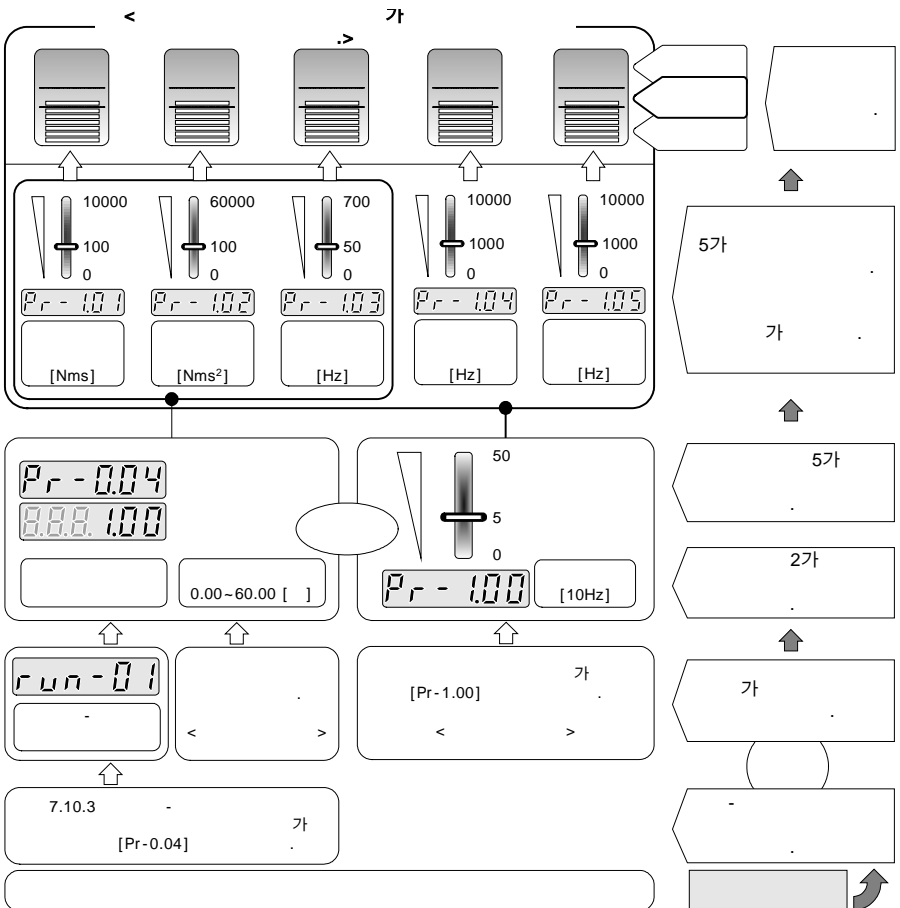

6.5 (, ,)

6.5.1

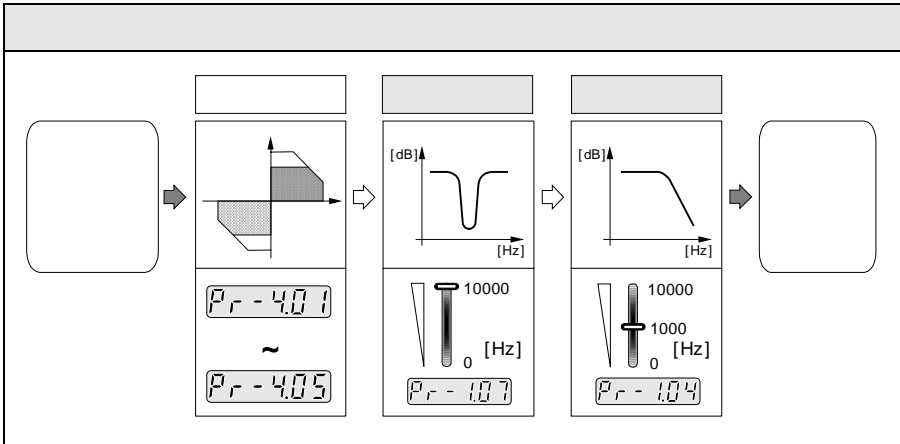

1.

 10000 0 Pr - 10.7 [Hz]	(Resonance)
ALL	-OFF > >

	<ul style="list-style-type: none"> ▶ = [Pr-1.07] ▶ [Pr-1.07] - ▶ - 7.10.3 ▶ 가
--	---

2.

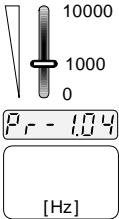
	<p>▶</p> <p>(Smoothing)</p> <p>▶</p> <p>▶</p>		
	ALL		-OFF > >

가

가
100[Hz]

[Pr-1.04]

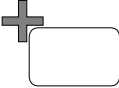
	<p>▶</p> <p>▶</p> <p>▶</p> <p>▶</p>	<p>CN1</p> <p>가</p> <p>[Pr-4.00]</p> <p>[Pr-4.00]</p> <p>가 [Pr-</p> <p>[Pr-4.00] 5.4.3</p> <p>5.4</p>	
--	-------------------------------------	---	--

6.5.2

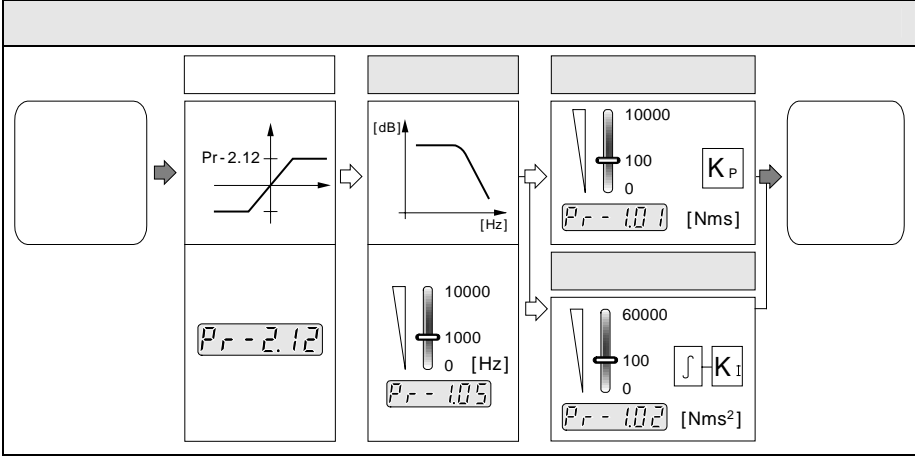

1.

		▶	
		▶	가
ALL			>

2.

		▶	
		▶	
		▶	
ALL			>

3.

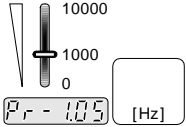
		▶ (Smoothing)
		▶ '0'
ALL		>

4.

- ▶ [Pr-1.01]
- ▶ 80 ~ 90[%] [Pr-1.01]
- ▶ (,)
[Pr-1.02] [Pr-1.02]

$$[\text{Pr-1.02}] \leq 300 \times [\text{Pr-1.01}]^2 \times ()$$

- ▶ [Pr-1.05]
- ▶ [Pr-1.04]
- ▶

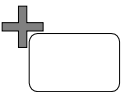
	▶ [Pr-1.01] [Pr-1.02] (Scaling)
	▶ , 100[W] 1[kW] [Pr-0.04]가 10[] [Pr-1.01] [Pr-1.02]

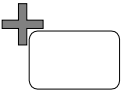
	▶ CN1 가 [Pr-2.00]
	▶ , [Pr-2.00] 2.00] 가 [Pr-
	▶ [Pr-2.00] 5.3.3
▶ 7.6 5.3.7	

6.5.3

FF , FF ,

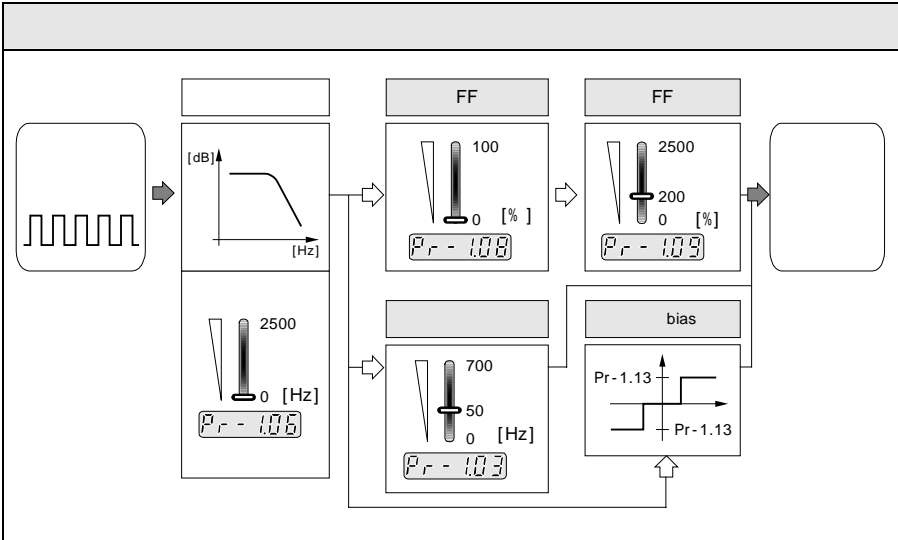

1.

		<p>▶ (Smoothing)</p> <p>▶ '0'</p>
ALL		>

2.

		<p>▶</p>
ALL		>

3.

- ▶ [Pr-1.03]
- ▶ [Pr-1.01] [Pr-1.01] 80 ~ 90[%]
- ▶ [Pr-1.03]
- ▶ ([Pr-1.02] [Pr-1.02])
- ▶ $[Pr-1.02] \leq 300 \times [Pr-1.01]^2 \times ()$
- ▶ [Pr-1.06]
- ▶ [Pr-1.08]
- ▶

 <input data-bbox="165 833 258 893" type="text"/>	▶ FF , FF (bias) 6.6
---	----------------------

6.6 tip

6.6.1 (Feedforward)

(FF) 6.5.3 FF 가



FF	
	▶
	>

FF	
	▶ (Smoothing) ▶ FF [Pr-1.08] '0' ▶ '0' FF ▶ [Pr-1.04]
	>

FF 가 (가) 가 FF 가 [Pr-1.04]
 [Pr-1.05] FF
 [Pr-1.06]



6.6.2

(bias)

가

가

가

가

	▶ 가 [Pr-1.13]		
	▶ [Pr-1.13] '0'		
			>

	▶ 가 [Pr-1.12]		
	▶ '0'		
			>

6.5.3

[Pr-1.13]

[Pr-1.12]

[Pr-1.12] [Pr-1.13]

	▶ [Pr-1.12] , [Pr-1.13]		
--	-------------------------	--	--

6.6.3 P/PI

[Pr-1.02]

'0'

[Pr-1.02]

가

'0'

'PI'

'P'

2가

1	P </P-CON>
2	P/PI

1. P </P-CON>

</ P-CON> . </ P-CON>
5.1 </ P-CON>

</ P-CON> 가 가

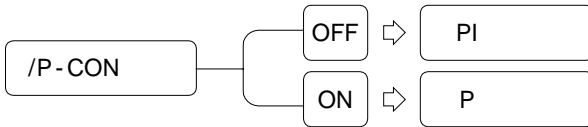

COM>, < /V-COM>, </TG-ON> </P-
'P' 'PI'

	<p>가</p> <p>'P' '0' 가</p>
--	-------------------------------------

'P'

() </P-CON>

'PI'

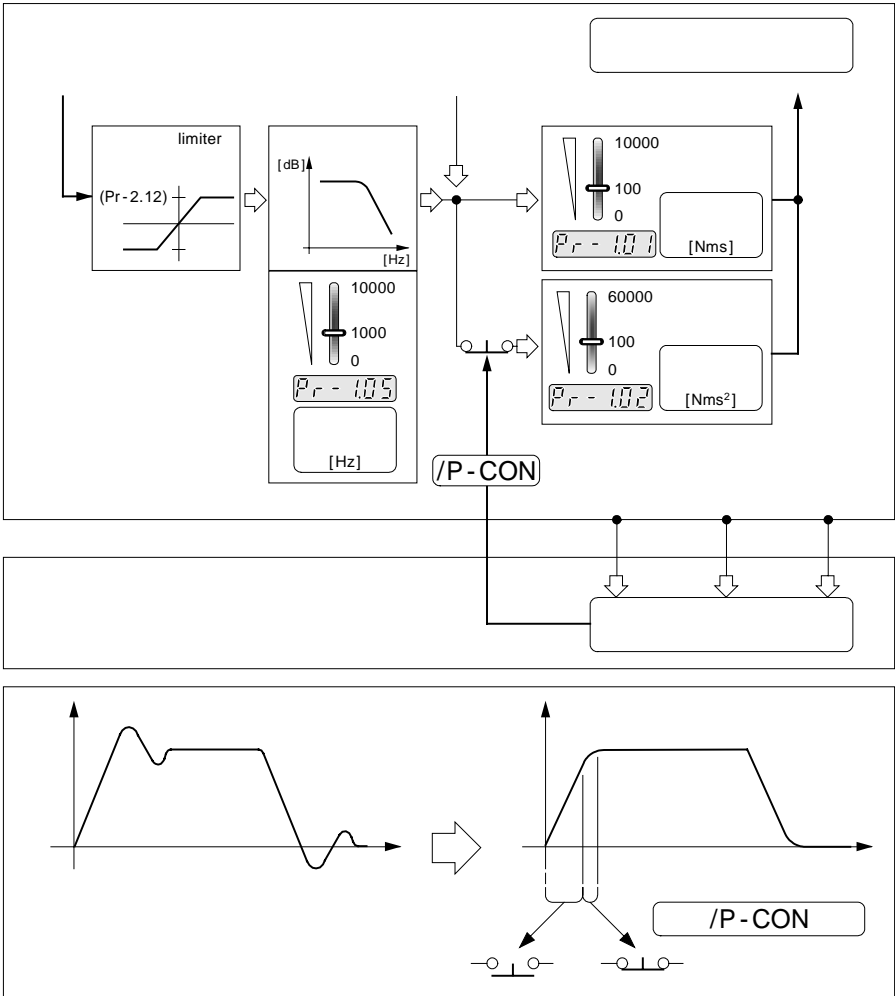

2.

P/PI

'P

- ▶ [%]
- ▶ [rpm]
- ▶ 가 [pulse]

Pr - 1.10		8.8.8.8.1		P
0	P/PI			
1	[Pr-1.11]	[%]	, PI -> P	
2	[Pr-1.11]	[rpm]	, PI -> P	
3	가 [Pr-1.11]	[pulse]	, PI -> P	
P, S, C		>		

Pr - 1.11		P		
		-OFF > >		
0~3,000	100	가	P, S, C	
▶ 100[%]		'P		

+	P	[Pr-1.11]	P	[Pr-1.11]
		[pulse]	[rpm]	[%]

⚠	▶ </P-CON> 가 [Pr-1.10] [Pr-1.11]
	</P-CON> 가 ON 'P' 가
▶	[Pr-1.10] [Pr-1.11]

'P' 가- 'P' 가

가 'PI' [Pr-1.11] 'PI' 가

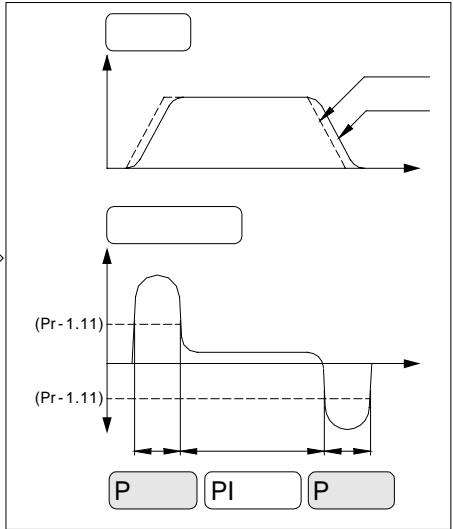
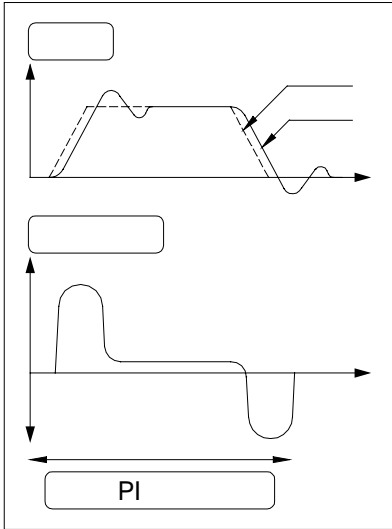

6.6.4

1.

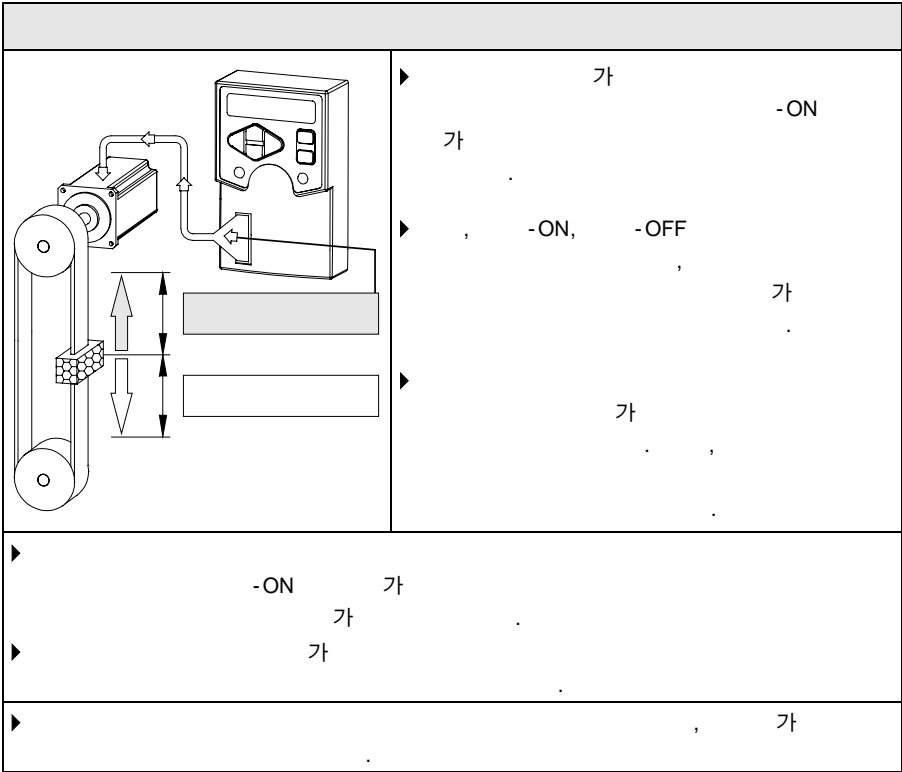



2.

1	(/) (/)
2	'0'
3	7.11 (dis-03) [Pr-4.06] 가 7.3
4	, ,

3.

Pr - 4.06				
				>
-100 ~ 100	0	[%]		ALL
▶	'0'		-ON	가
▶			가	, 가
▶				

 	▶	7.2
	▶	7.2

	▶	[Pr-4.06]	-ON
	▶	가	

6.6.5 </G-SEL>

가 가 가
가

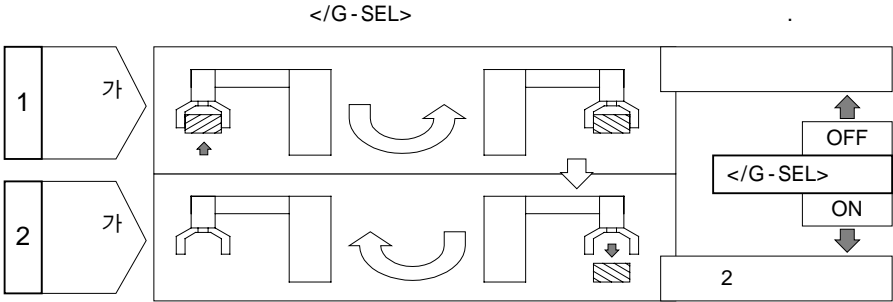

</G-SEL>

1	2
2	run-11 2 [Pr-1.01 ~ Pr-1.05] (run-11 7.10 .)
3	1 . ()
4	5.1 </G-SEL>
5	1 , 2 </G-SEL>

2

</G-SEL>

. </G-SEL>
</G-SEL>

5.1

	▶ </G-SEL>
--	------------

가

7.1	149
7.1.1	149
7.1.2	(8.2.2).....	149
7.1.3	<P-OT>, <N-OT>.....	149
7.1.4	(Dynamic Brake)	151
7.2	152
7.3	156
7.4	157
7.4.1	157
7.4.2	158
7.4.3	159
7.5	165
7.6	167
7.7	169
7.7.1	169
7.7.2	170
7.8	172
7.9	174
7.9.1	?.....	174
7.9.2	175
7.9.3	175
7.9.4	177
7.9.5	178
7.10	181
7.10.1	181
7.10.2	(run-00).....	182
7.10.3	- (run-01).....	183
7.10.4	(run-02)	184
7.10.5	(run-03)	185
7.10.6	(run-04)	186
7.10.7	(run-05)	187
7.10.8	(run-06)	188
7.10.9	(run-07).....	189
7.10.10	(run-08)	190
7.10.11	(run-09).....	191
7.10.12	(run-10).....	192
7.10.13 2	(run-11).....	192

7.10.14	(run - 12)	193
7.11	194
7.11.1	194
7.11.2	196

7.1

7.1.1

가

1. 가



2. 2가 가

▶ 가

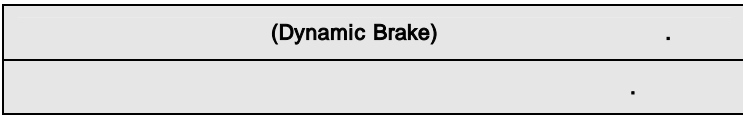

7.1.2 (8.2.2)

8.2.2

7.1.3 <P-OT>, <N-OT>

1. (OT)

가

가

▶ 가

▶ 가

가

▶ 가

<P-OT>

<N-OT>

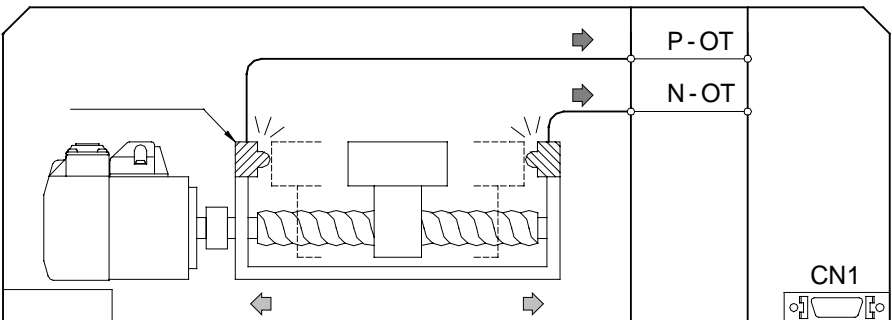

2.

<P-OT>		
<N-OT>		

3.

▶ <P-OT>, <N-OT> 5.1 . <P-OT>, <N-OT> <P-OT>, <N-OT>

▶ CN1 4 <P-OT> 가, CN1 5 <N-OT> 가

+	▶ 가 가 가
+	▶ 4.1.4

+	▶ 7.10.4
+	▶ 7.10.4

4.

▶

Pr - 0.02 8.8.8.00		
0	5.4.4	
1	7.1.4	
	ALL	-OFF > >

+	▶ [Pr-0.02] '0'
+	▶ 5.4.4

7.1.4 (Dynamic Brake)

1. (DB) (U,V,W) 가 가 (DB) DB 가 가 DB 가 DB DB DB
- ▶ DB

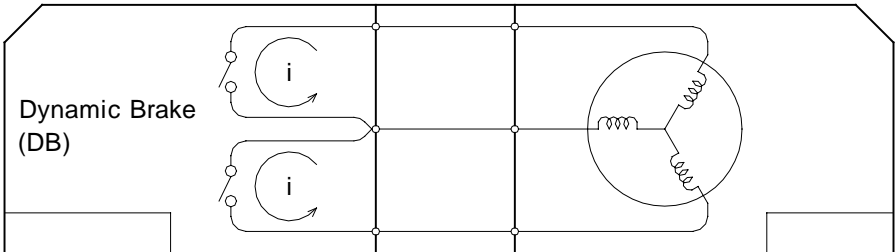

2. DB 가 DB 가
3. (Free Run) 가 (Free Run)
4. DB DB

Pr - 0.02		8.8.8.8.8.0		DB
0	DB	DB		
1	DB	DB		
2	DB			
	ALL			-OFF > >

7.2

1.

가

- ▶ 가 (:)
- ▶ OFF , -OFF

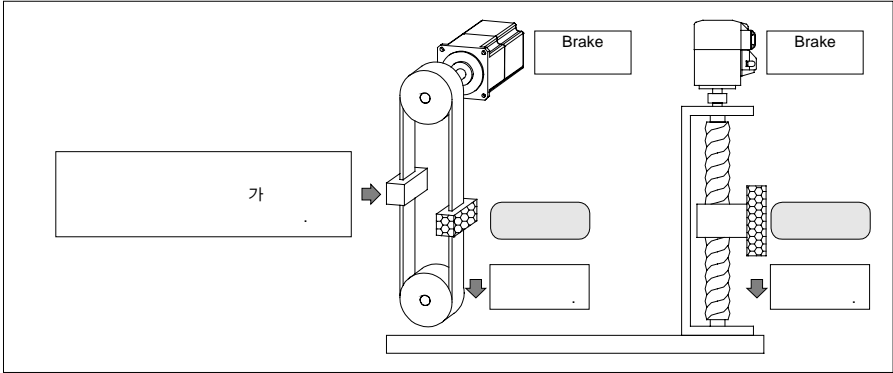

2.

- ▶ 5.1
- ▶ <BK> 가
- ▶ DO#3 (CN1 47, 48)

3.

- ▶
- ▶
- ▶ CN1

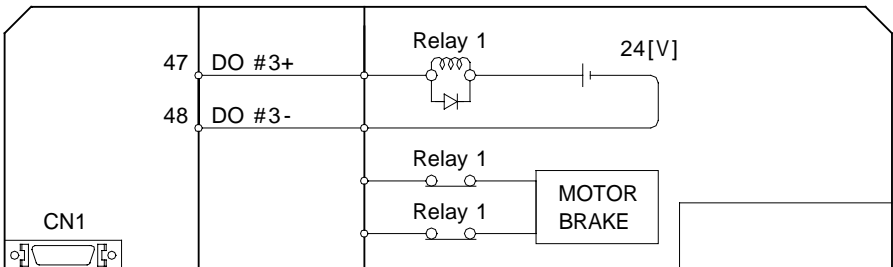

4.

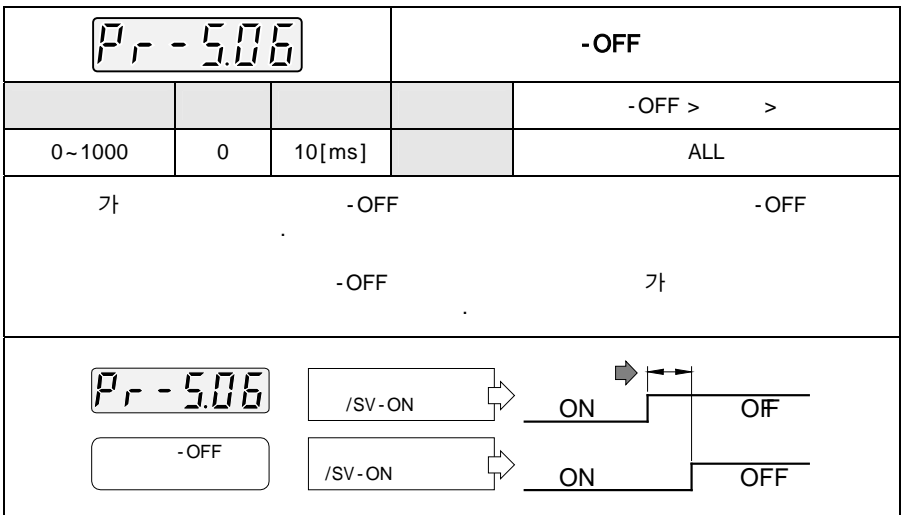
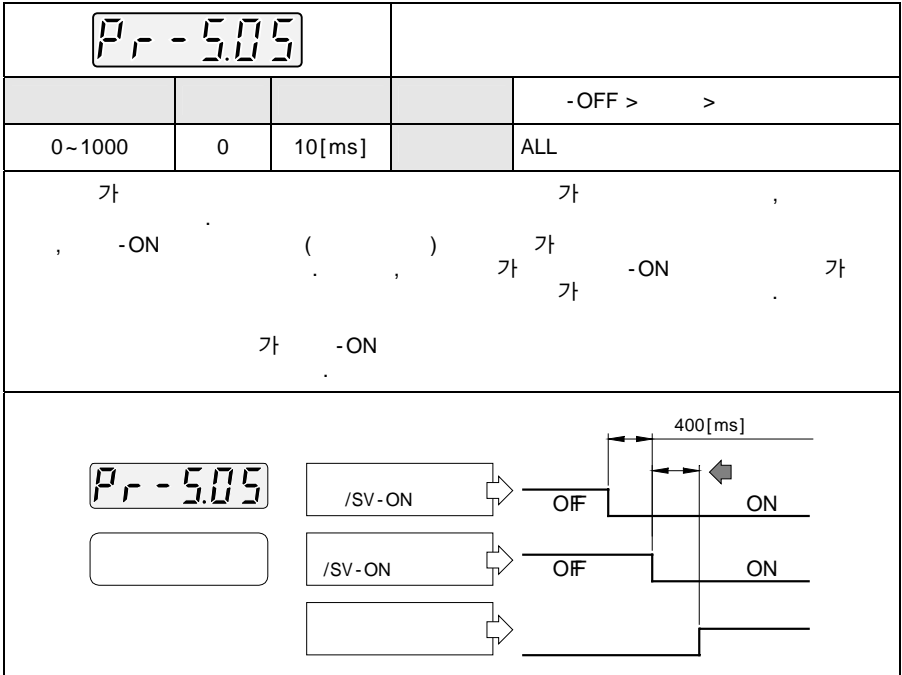

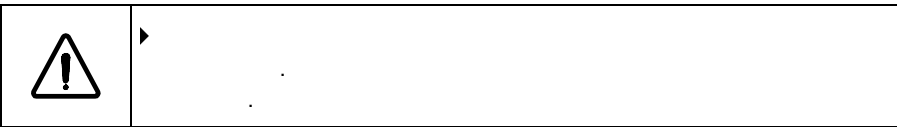
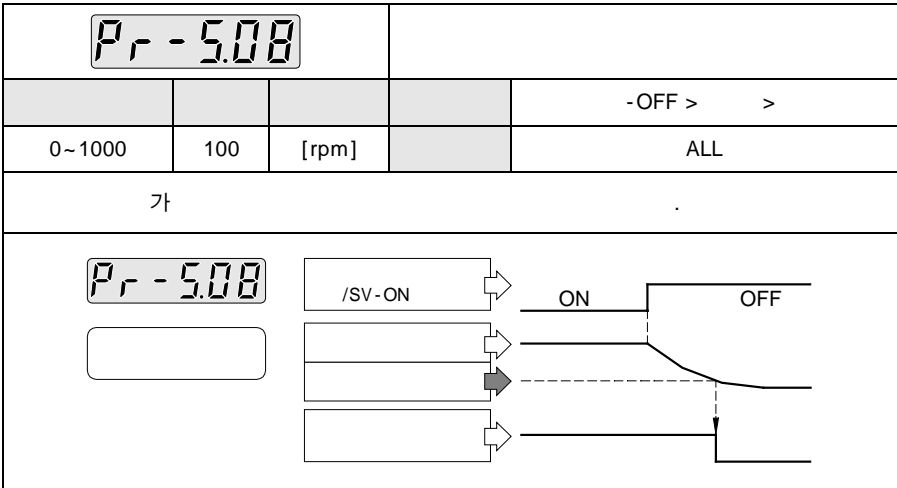
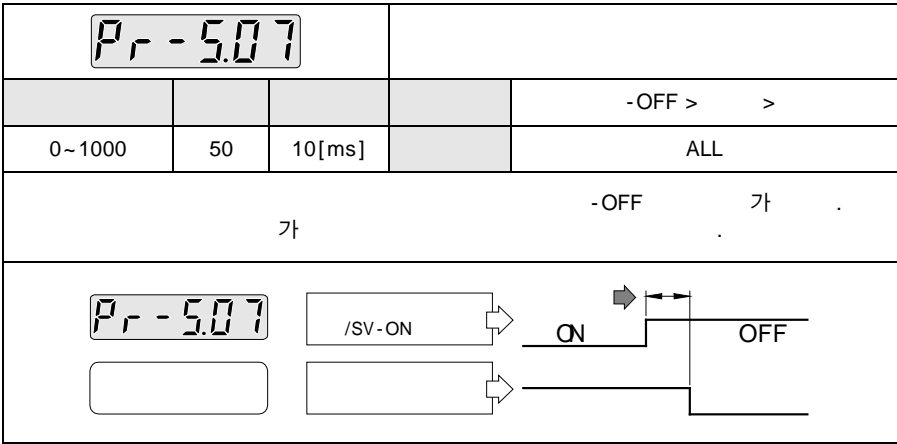

5.

-ON

-OFF

▶

-OFF 가

가

▶

-OFF 가

가

▶

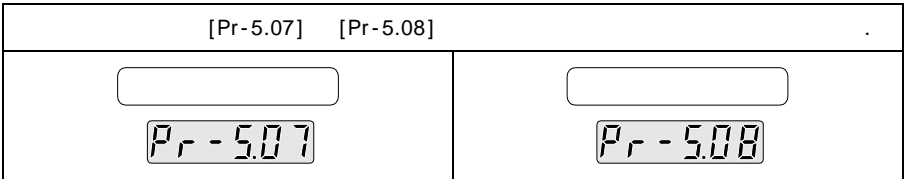
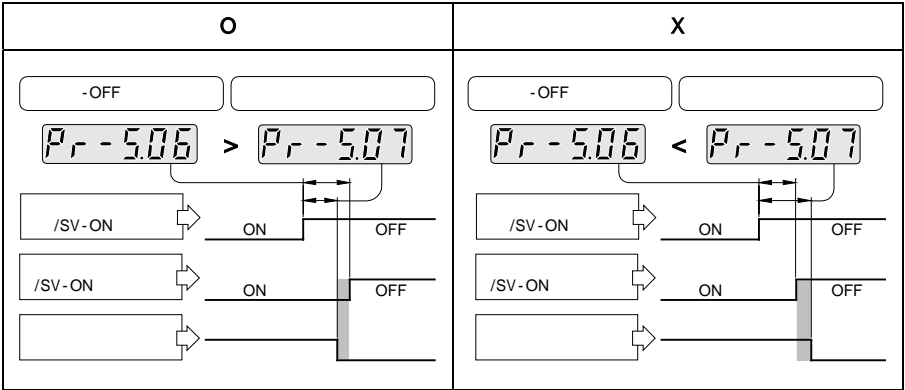

6.

▶

가

▶

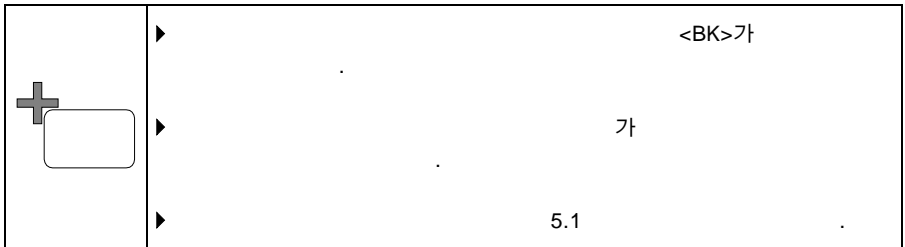

7.3

1.



2. - CW (Clock Wise)

3. - CCW (Counter Clock Wise)

4.

Pr - 0.02		8.8.8.0.8.8		
0	CW			
1	CCW			
	ALL		- OFF >	>

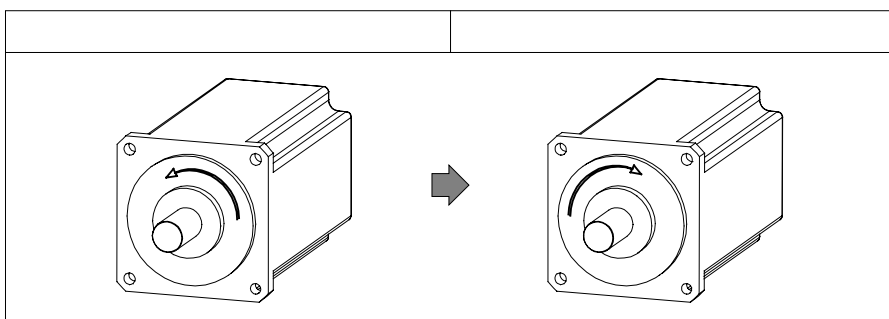

+	▶	[run-01]	
	▶		가
	▶		7.10.2

7.4

7.4.1

1.



2.

▶ 가

가
가



가 가
가

3.



4.

▶ 가

가

7.4.3

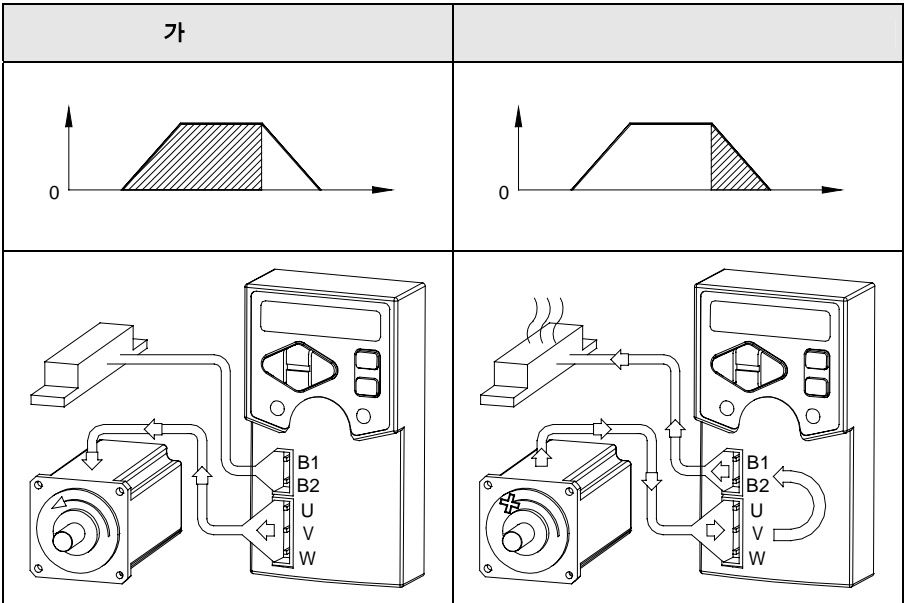

5.

50[%] ,

25[%]

	[Ω]	[W]	[W]	
200[W]	-	-	-	-
400[W]	50	30	7.5	X
1[kW]	50	70	35	O
1.5[kW]	30	70	35	O

7.4.2

가

1.

가

▶ 가

2.

▶ 가 가

30~50[Ω]

	▶ 가 200
	▶ 가
	25[%]

	▶ 가 가
	▶

7.4.3

1.

가

▶

가

1

▶

<input style="width: 100%; height: 100%;" type="text"/>	$= \frac{\quad}{1+n} \times \left(\frac{\quad}{\quad} \right)^2 \text{ [Cycles/Min]}$
▶	[1] [1]
▶	(n)
▶	

	▶ 가
--	-----

[1]

가-

<input style="width: 100%; height: 30px;" type="text"/>	
▶	$= \frac{1}{T} \times 60 \text{ [Cycles/Min]}$

[1]

(Minute)



[Cycles/Min]										
[W]	300	400	500	600	750	800	900	1000	1200	1500
CSM		320		70		53		90		
CSMP		40								
CSMD					69			31		17
CSMF		35			19					9
CSMH			14					7		4
CSMK	54			76			40		14	
CSMQ		46			61					30
CSMS								43		27
CSMZ		88			63					
CSMT										
CSMA										

 <input style="width: 80px; height: 30px;" type="text"/>	<p style="text-align: right;">가</p> <ul style="list-style-type: none"> ▶ 가 ▶ 7.5 가 ▶ 5.4.4 가 ▶
--	--

가	2
---	---

2.

W _K	
$W_K = \frac{E_K}{0.2 \times T}$	T= 0.2 20[%]
▶ [1]	[]

E _K	
$E_K = E_M - (E_L + E_R + E_C)$	E _M
	E _L
	E _R
	E _C

	▶ ▶ ▶	7.4.2 [Pr-5.11]
---	-------------	--------------------

	▶
---	---

[]

E _M	
$E_M = \frac{(J_L + J_M) \times N_M^2}{182}$	N _M = [1]
	J _M =
	n = 6.1.3

E _L	
$E_L = \frac{\pi}{60} (N_M \times \tau_L \times T_D)$	τ _L = [1]
	T _D = [1]
E _L = 0	

E_R	
$E_R = \frac{3}{2} \times R_a \times \left(\frac{\tau_L}{K_T} \right)^2 \times T_D$	$R_a =$
	$K_T =$

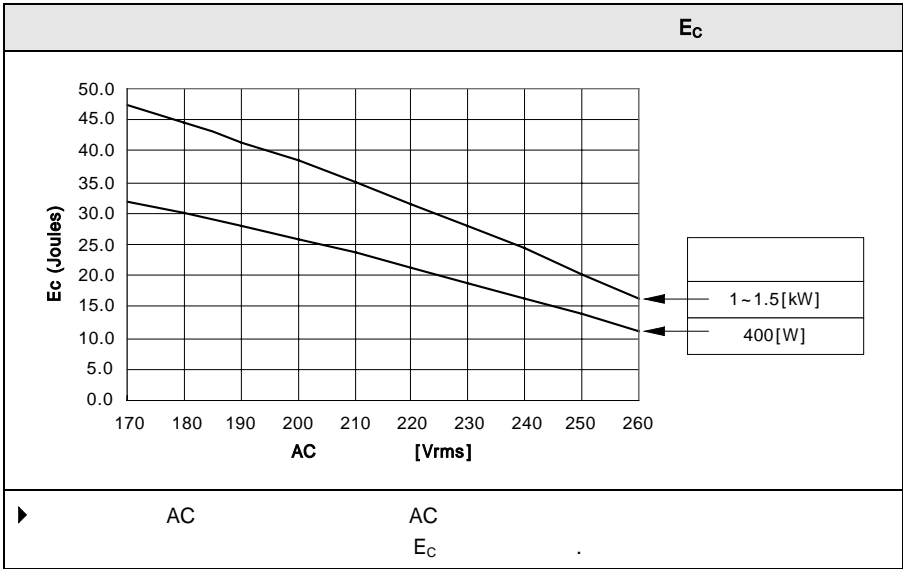

	$E = [\text{Joules}] = [\text{kg} \cdot \text{m}^2 / \text{s}^2]$		$\tau = [\text{N} \cdot \text{m}]$
	$J = [\text{kg} \cdot \text{m}^2]$		$T = [\text{s}] = 1/60 [\text{Min}]$
	$N = [\text{RPM}] = 60/2\pi [\text{rad/s}]$		$K_T = [\text{N} \cdot \text{m/A}]$

3.

E

2

E	
$E_K = E_M - (E_L + E_R + E_C) + E_G$	E_G
$E_M - (E_L + E_M + E_C)$	2

E_G		
$E_G = \frac{2\pi}{60} (N_{MG} \times \tau_G \times T_G)$	$N_{MG} =$	[2]
	$\tau_G =$	[2]
	$T_G =$	[2]

[2]

가-

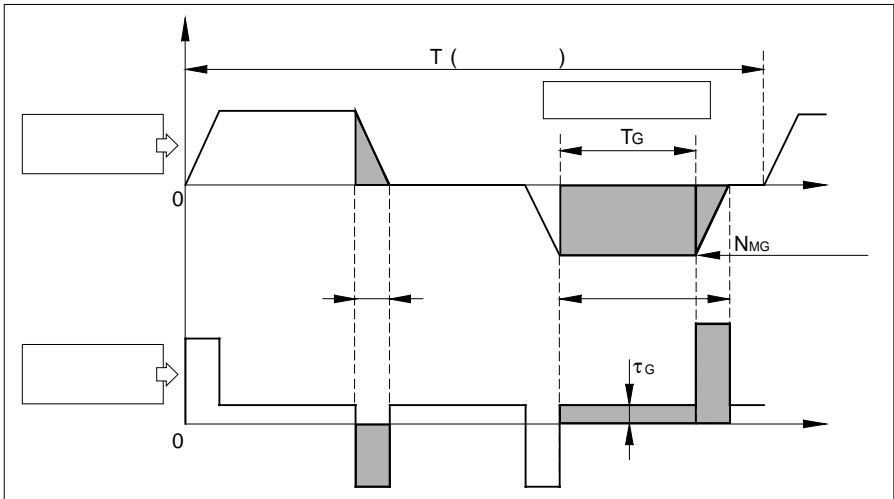

+	▶ 7.11	[dis-10]
---	--------	----------

4.



50[%]
) 400W

Pr-5.11

30W

Pr-5.11



15

Pr-5.11				
				-OFF > >
0~1500		[W]		ALL

	[W]
200[W]	-
400[W]	15

	[W]
1[kW]	70
1.5[kW]	70

	▶	가 200
		가
		25[%]

	▶	200[W]
		가

7.5

1.

▶ 가 S- 가

2. 가

▶

3.

▶

4. 가

▶ 가

▶

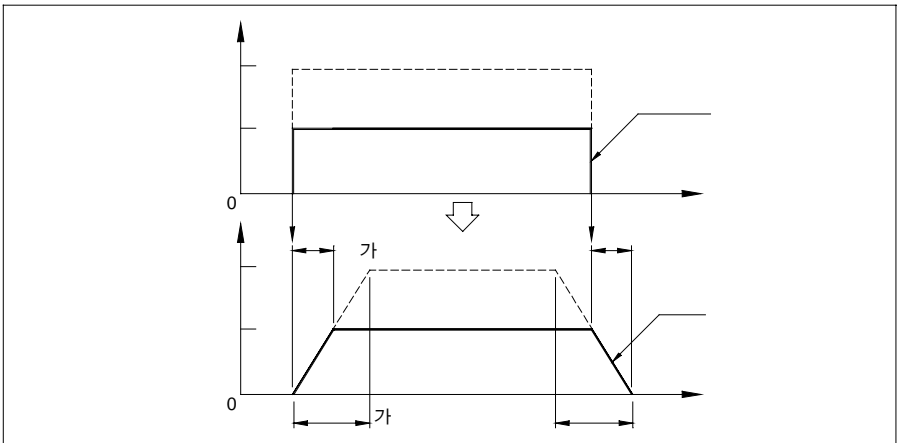

5. 가-

▶ 가-

Pr-202			가	
				>
0~60000	0	[ms]		ALL

Pr-203			가	
				>
0~60000	0	[ms]		ALL

6. S-



가-

S

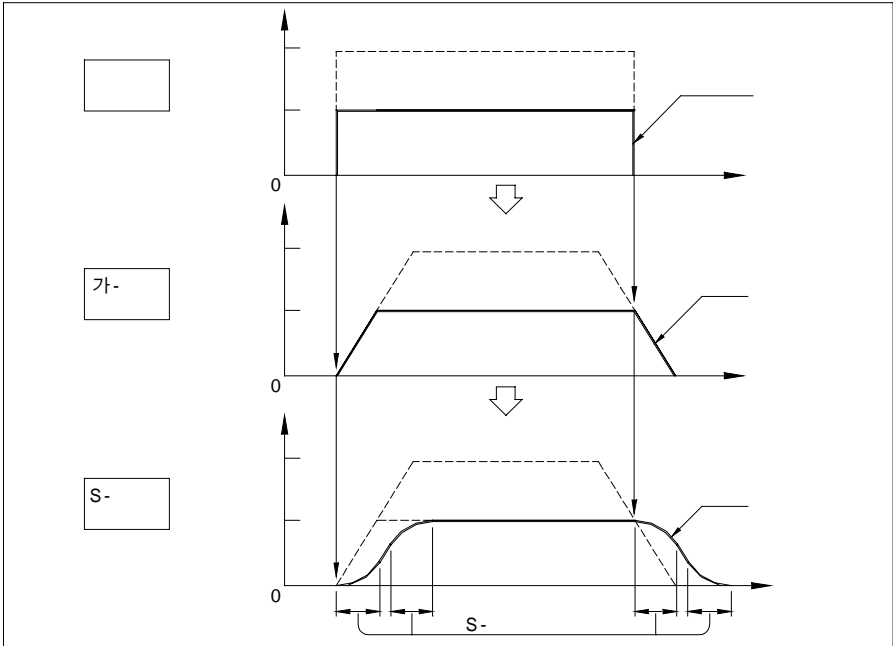

7. S-

S-

Pr-2.04			S-	
				>
0~5000	0	[ms]		ALL

8.

가

S-



10

가

가

10 + [Pr-2.03]

S-

10 + [Pr-2.03] + [Pr-2.04]

+	▶ S-	'0'	S-
	▶ , 가-		S-
	S-		가-

7.6

1. 2가
 - ▶ . ()
 - ▶ . ()
2.
 - ▶ 가 가

Pr - 2.12				
				-OFF > >
1~5000		[rpm]		ALL
▶ 4.2				

3.
 - ▶ 가 가
 - ▶ . 5.3 (,)
 - ▶ 가
 - ▶ .
 - ▶ .

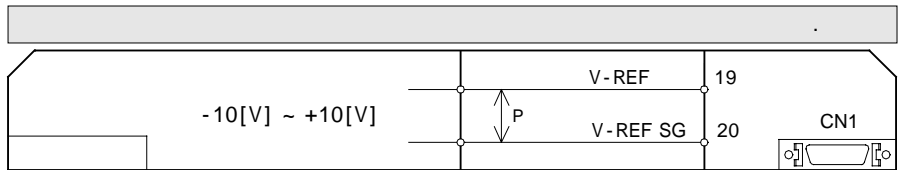
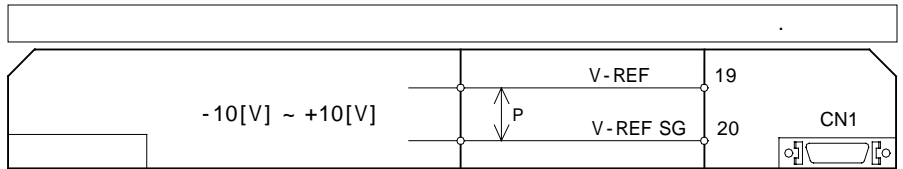

4.



Pr - 2.00				
				>
10.0~2000.0	500.0	[rpm/V]		S
1[V]		[rpm]		

$$\begin{array}{c}
 \boxed{\text{[rpm]}} = \boxed{\text{Pr - 2.00}} \text{ [rpm/V]} \times \boxed{\text{[V]}} \\
 \text{10[V]} \qquad \qquad \qquad \frac{6\text{[V]}}{5000\text{[rpm]}} \qquad \qquad \qquad 3000\text{[rpm]}
 \end{array}$$

5.

V-REF (CN1 19) V-REF SG (CN1 20)
 -10[V]~+10[V] 가 +
 +,-
 +1[V] 가 [Pr-2.00] 500
 500[rpm]
 , -1[V] 가 , 500[rpm]

6.

Pr - 2.13		8.8.8.8.0		
	0			
	1	[Pr-2.12]		
	2	[]		
	3	[Pr-2.12]		
		ALL		-OFF > >

7.7

1.

가

가

2.



5 가

1	EA	A (/A)	
	/EA		
2	EB	B (/B)	
	/EB		
3	EC	C (/C)	
	/EC		
4	PS		
	/PS		
5	/Z-PULSE+	Z (+/-)	
	/Z-PULSE-		

3.



3.8

7.7.1



Pr - 300		8.8.8.08.8		
	0	A	90°	
	1	B	90°	
	ALL			- OFF > >

7.7.2

1.



2.



$$\frac{\text{Pr-3.03}}{\text{Pr-3.04}} \times \quad =$$



1 가 1 2048

$$\frac{\text{Pr-3.03} \text{ 88.1000}}{\text{Pr-3.04} \text{ 88.2048}} \times 2048 = 1000$$



1000 1 2048

3.

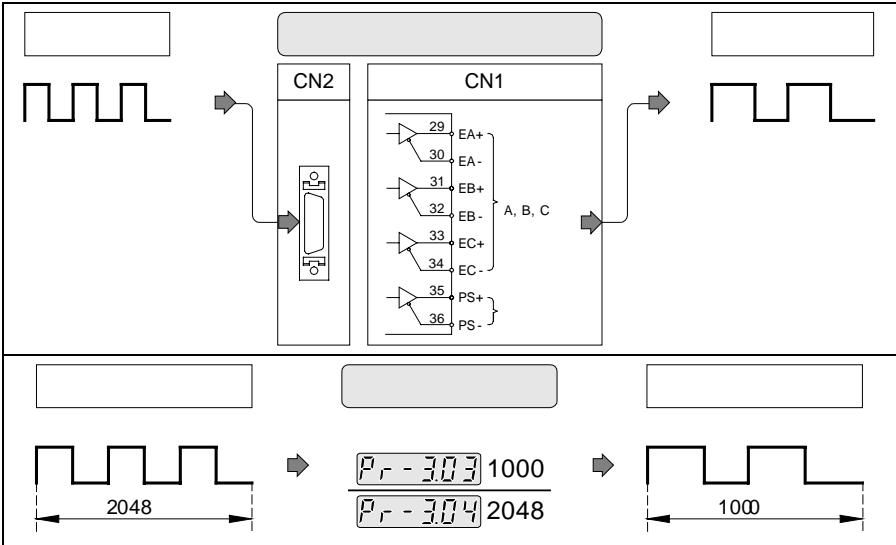

4.

				()
				-OFF > >
1~65535		[Pulse]		ALL

				()
				-OFF > >
1~65535		[Pulse]		ALL

		4.2	Type
--	--	-----	------

		가	33[usec] (Jittering)
--	--	---	----------------------

5.

7.8

1.

가

▶ 가 가 2 가

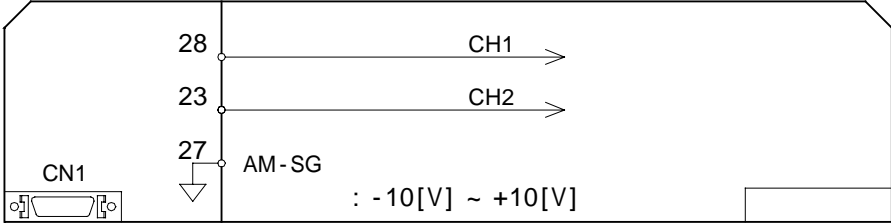

2.

▶ 가

Pr-5.12		0-0500		CH1	
				>	
0-0001 ~ 6-2500	0-0500			ALL	

Pr-5.13		3-0500		CH2	
				>	
0-0001 ~ 6-2500	3-0500			ALL	

▶

		No.		
<div style="border: 1px solid black; padding: 5px; margin-bottom: 5px;">No.</div> <div style="font-size: 2em; font-weight: bold; margin-bottom: 5px;">0-0500</div> <div style="border: 1px solid black; padding: 5px; margin-bottom: 5px;"></div>		0		1~500 [rpm]
		1		1~30 [%]
		2		1~5000 [pulse]
		3	Feedback	1~500 [rpm]
		4	Feedback	1~30 [%]
		5	Feedback	1~5000 [pulse]
		6		1~2500 [pulse]

3.



1[V]
-10[V]~+10[V]

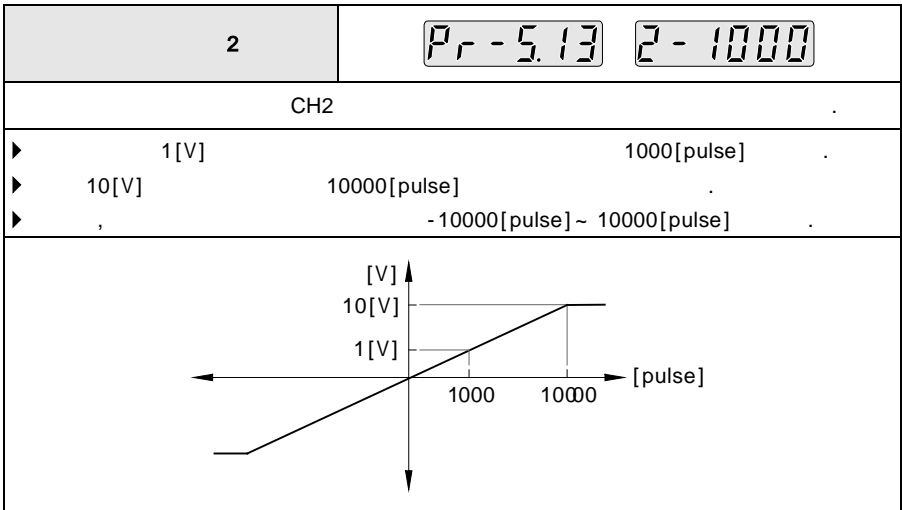
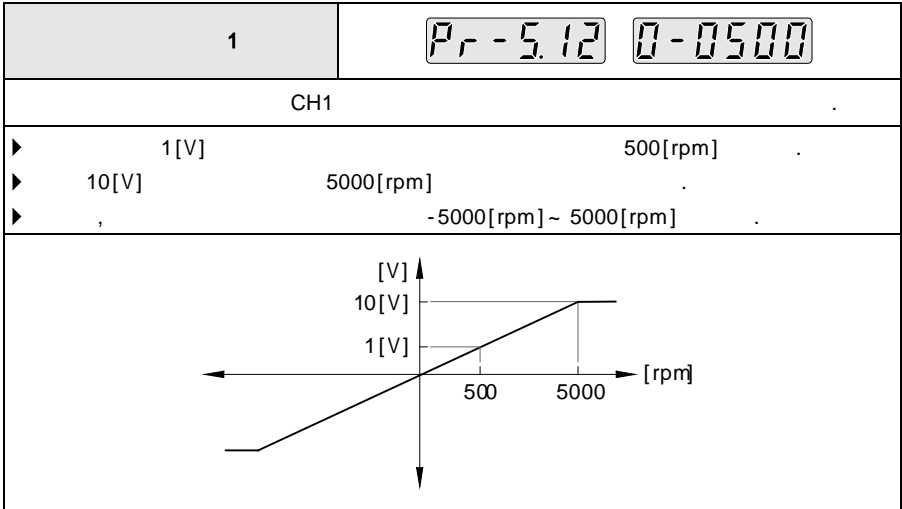

7.9

7.9.1

?

- ▶
- ▶
- ▶
- ▶
- ▶

가

가

가

가

가

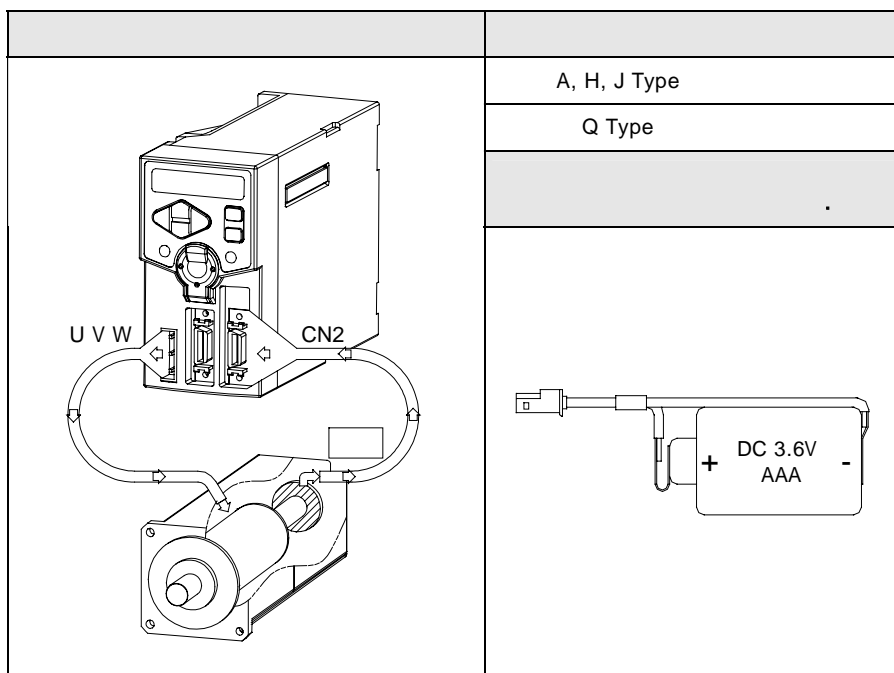

7.9.2

가



CN1 49, 25 CN5

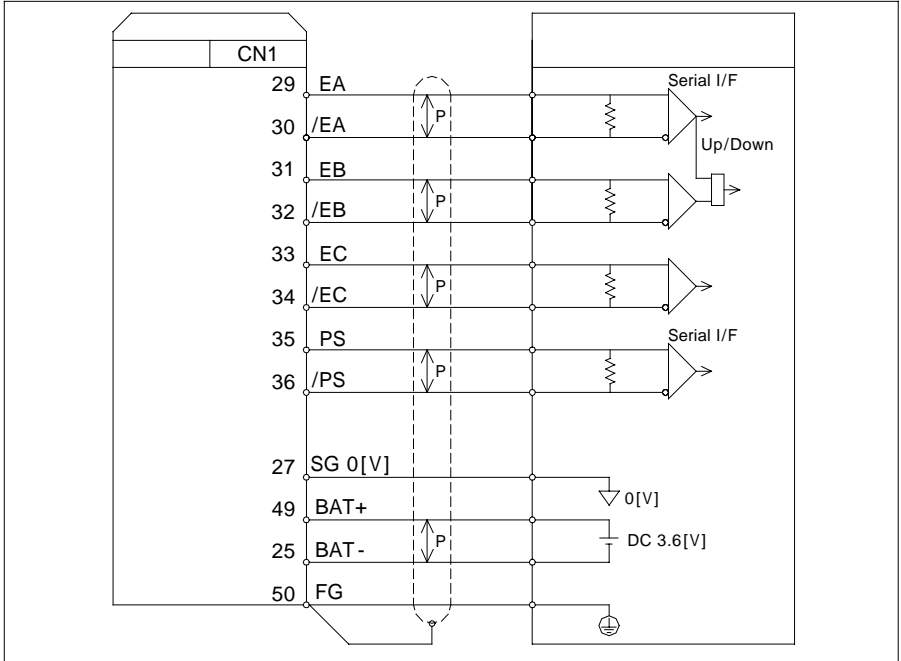

7.9.3

1.



▶ CN5 : 가

▶ : 3.6[V] , 1/2 AA (AAA)



2.



CN5

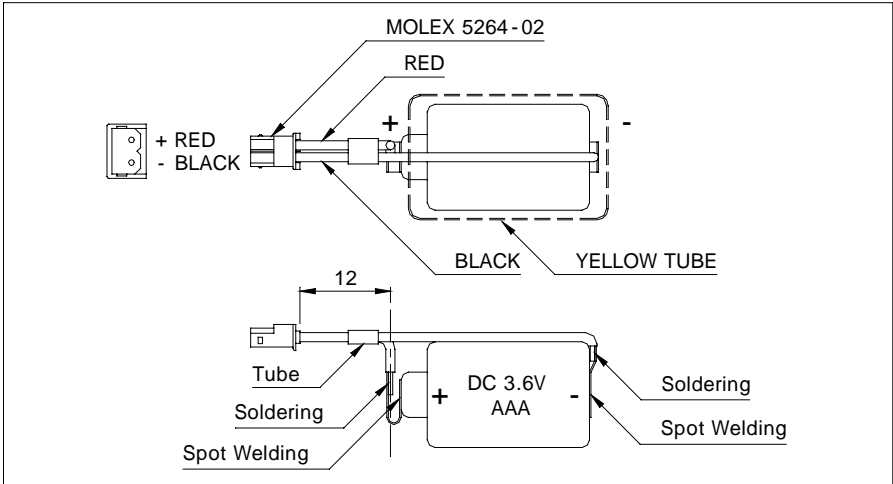

3.



가	3.2[V]	가	2.7[V]
AP.6AE		E.A656E	
+	Type 가 H, J, A Q Type (CSME 가) (run-08) 가 30 가		

4. CN5



CN5

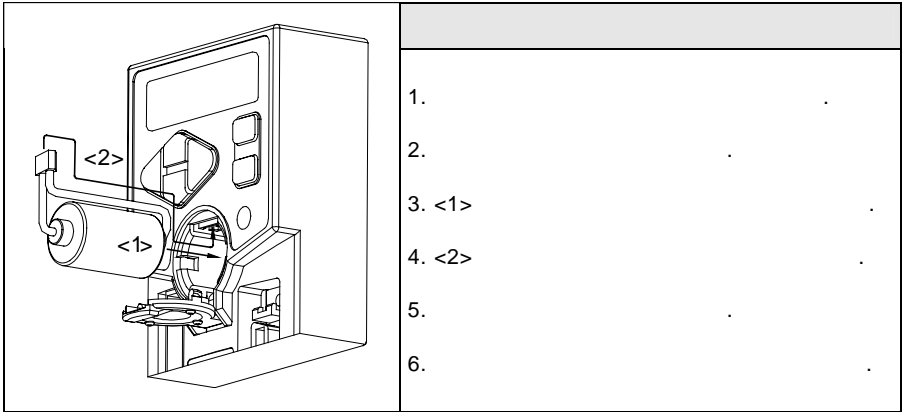

7.9.4

(run - 10)



가



-OFF

가

▶ A, H, J Type

3~5 가



	A, H, J Type	Q Type
(run - 08)		
(run - 10)		

	<p>▶ A, H, J Type</p> <p style="text-align: right;">가</p> <p>▶ Q Type</p>
--	---

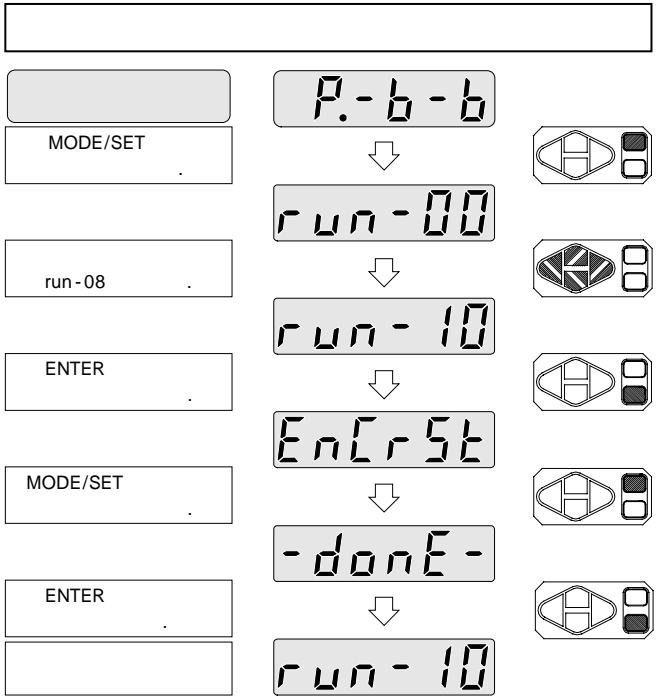

7.9.5

가



PS(+,-), EA(+,-), EB(+,-)

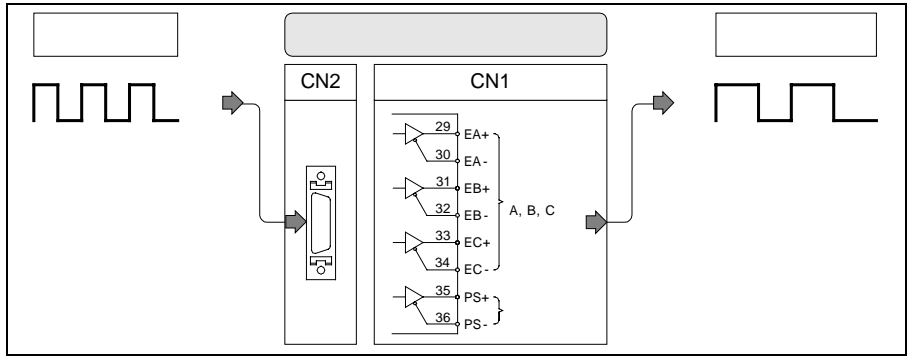

1. PS (+, -)

▶ PS

▶ “ & 1 ”

가

		1	
A, H, J Type	13	11	50[ms]
Q Type	16	17	50[ms]

STX	(가)			&	(3bit)	BCC	ETX
	(0~65535)	&	1 (1~131071)				

	(Asynchronous)
Baud rate	9600[bps]
Start Bit	1 bit
Stop Bit	1 bit
	None
Character code	ASC Code
Data format	10 ~ 19 characters

+	▶ 7.11 (dis-12)
---	-----------------

2.

- ▶ STX , ASCII 02H
- ▶ ETX , ASCII 03H
- ▶ -32768 ~ +32767 (-4096~+4095) 가 ,
 +32767(+4095) -32768(-4096) -32768(-4096)
 +32767(+4095) . (A, H, J Type)

3. EA (+, -), EB (+, -)

- ▶ PS (+, -)

EA, EB

1[Mpps]

1

EA, EB

1. (/ABS-DT 10[ms] LOW
 /ABS-DT 5.1)
2. UP/DOWN 0
3. 100[ms]
4. , 100[ms] 1
5. EA, EB 1 50[ms]

PAO

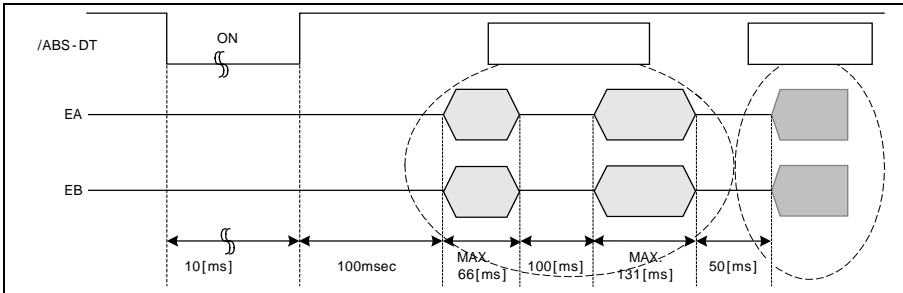

EA (+, -)	ON 가	
EB (+, -)	ON 가	
EC (+, -)		
PS (+, -)		

7.10

7.10.1

- 1.
- 2.
- 3.
- 4. -ON, -OFF
- 5. (run-00) ~ (run-12)
- 6.

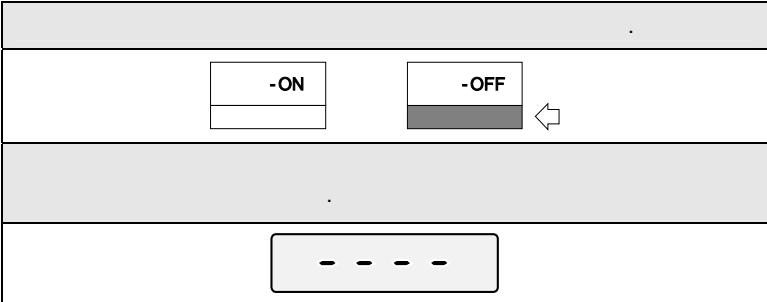

7.10.2 (run-00)

1.

- ▶
- ▶ [Pr-2.01] [Pr-2.01]
- ▶ 0~5000[rpm] 가 500[rpm]

2.

▶

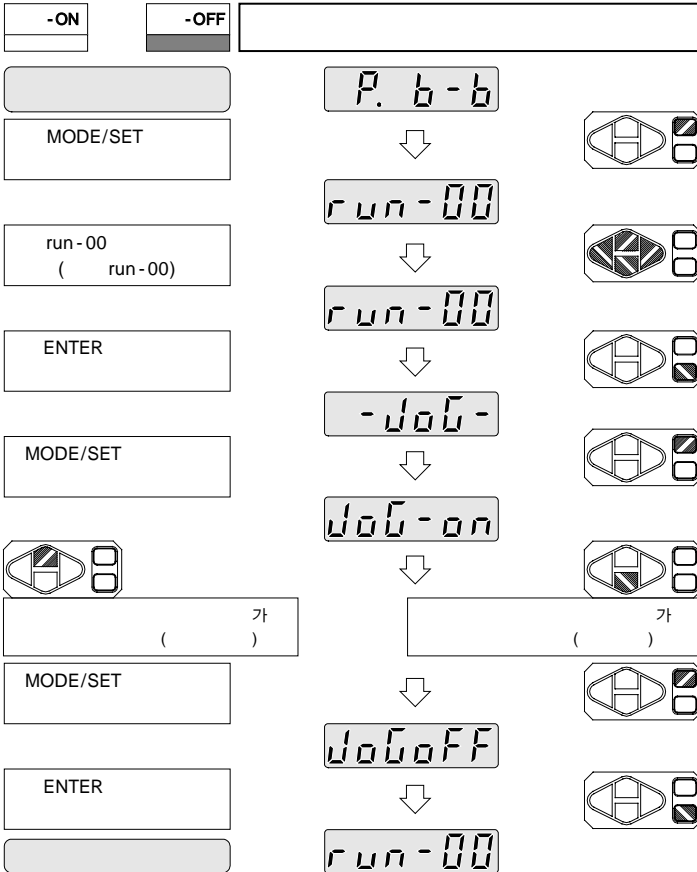

7.10.3 - (run-01)

1.

6.3

2.

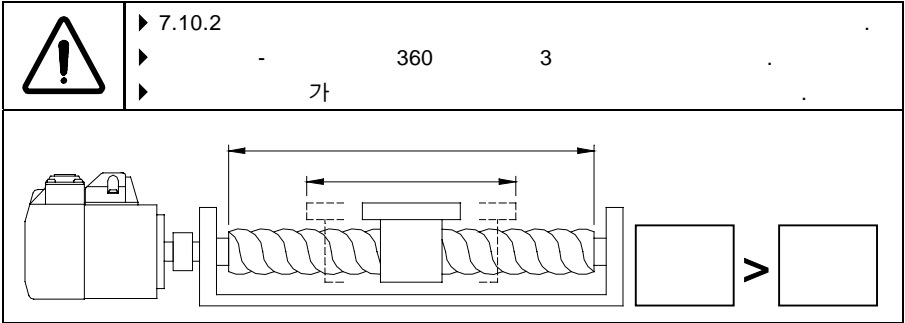

3.

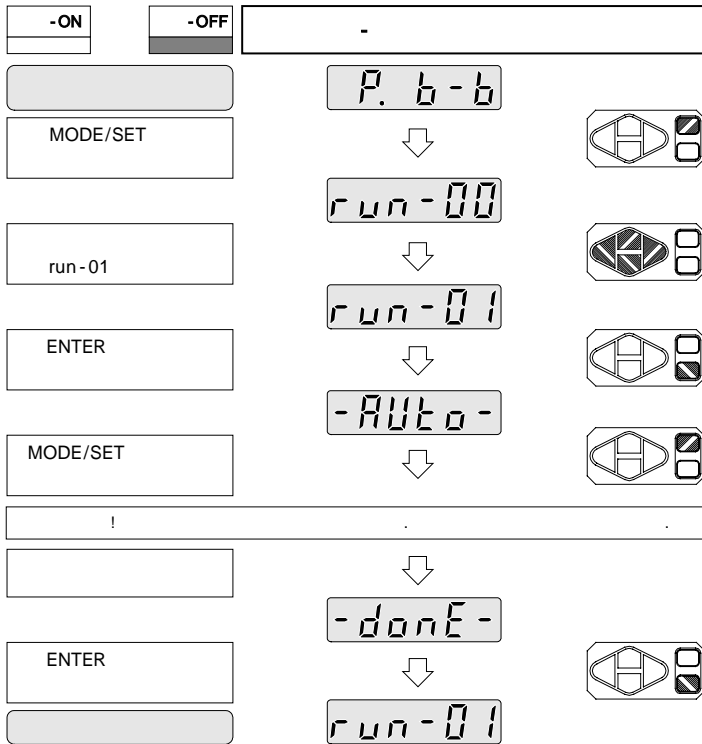

7.10.4

(run-02)

가 , 가 .

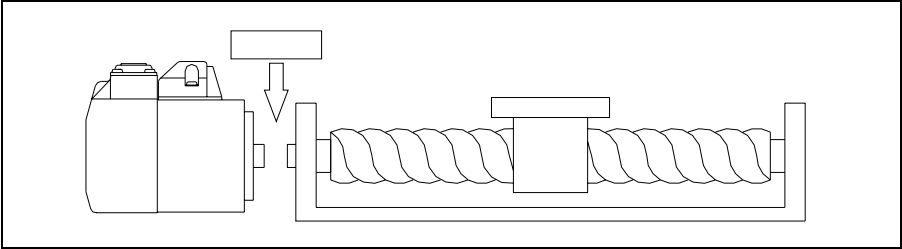

-ON
10[rpm]

7.10.5

(run-03)

1.

▶ 가 0[V]
▶ 가

2.

▶ CN1 0[V]
▶ , 가
▶ 가 0[V]

3.

▶ 가 -1[V]~+1[V]
▶ 가
▶ 7.11 [dis-13]
▶ 5.3.4 Zero-Clamp

4.

▶

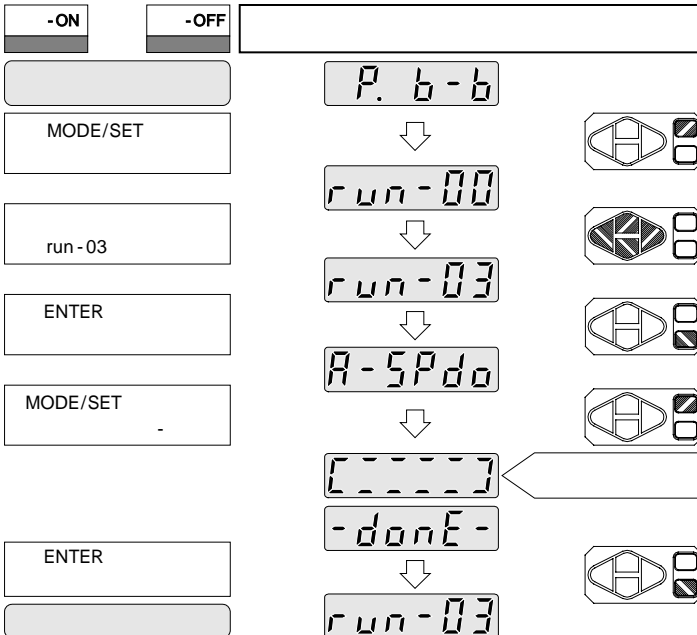

7.10.6

(run-04)

1.

▶ 가 0[V]
▶ 가

2.

▶ CN1 0[V]
▶ 가 가
▶ 가 0[V]

3.

▶ 가 -1[V]~+1[V] 가
▶ 7.11 [dis-14]

4.

▶

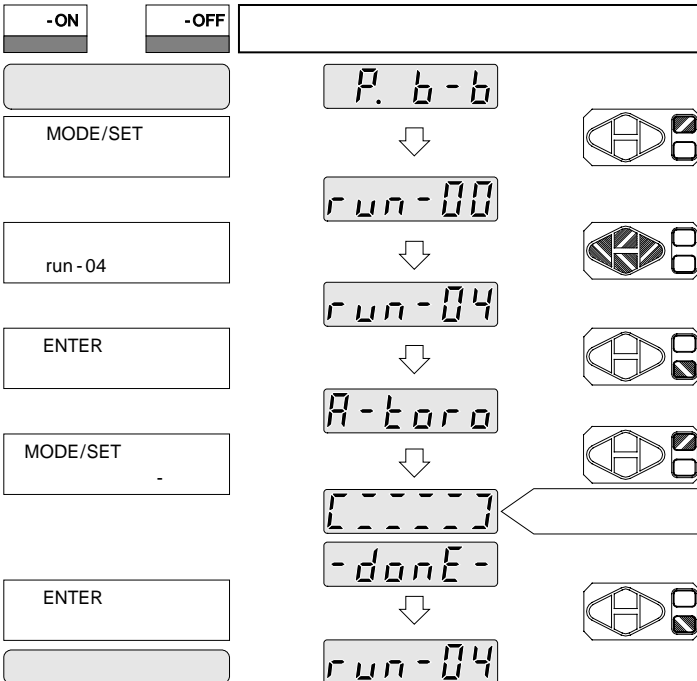

7.10.7

(run-05)

7.10.5

- ▶
- ▶

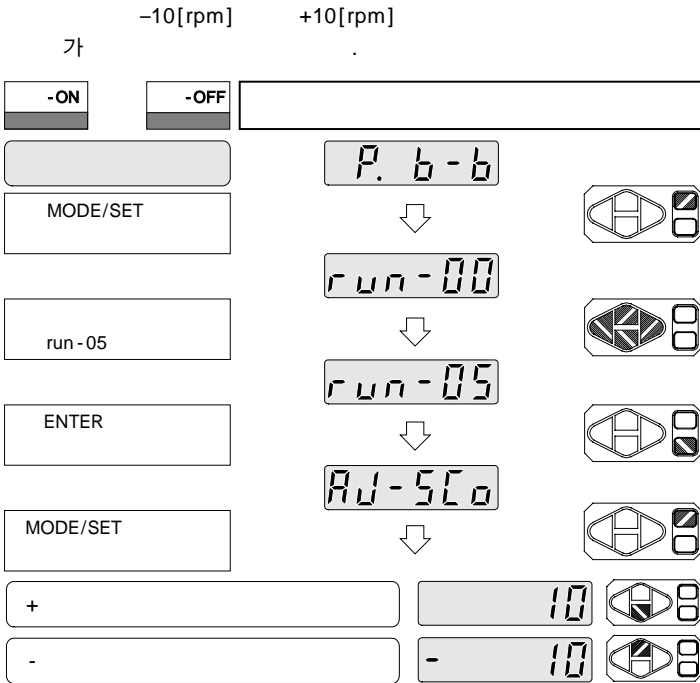

- ▶
- ▶
- ▶

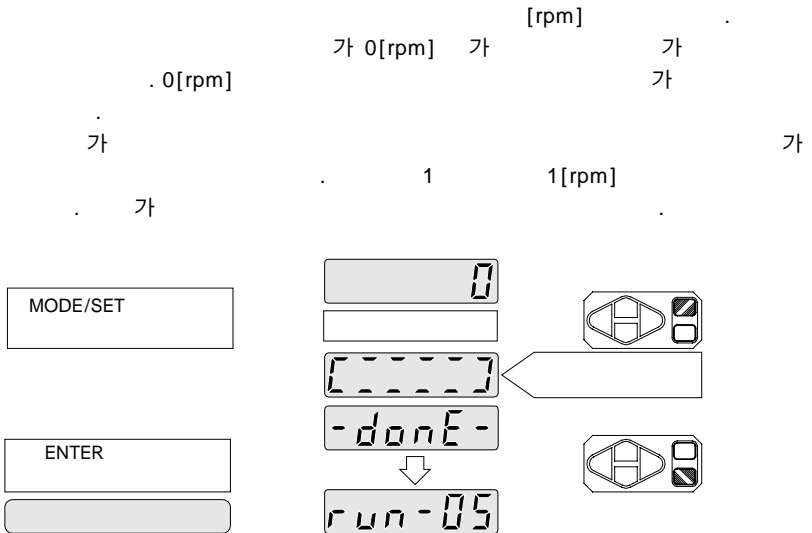

7.10.9

(run-07)

1.



가



2.



-OFF

가



7.10.14

[run-12]

가



3.

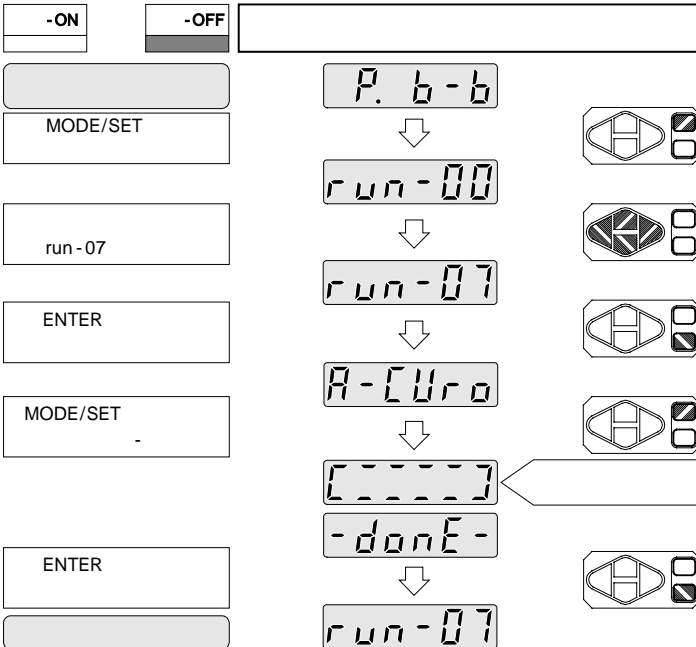

7.10.10

(run-08)

1.



가



가 가

2.

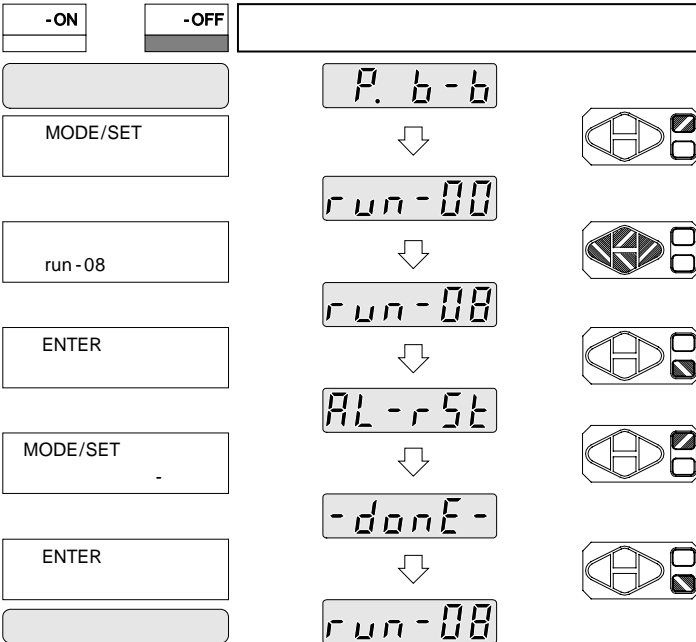

3.

</A-RST>



</A-RST>

. 5.1

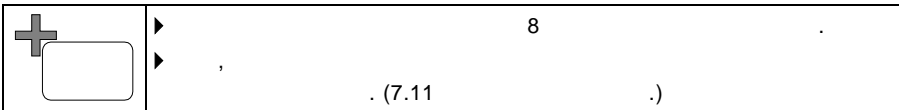

7.10.11

(run-09)

1.



[dis-16]

[dis-16]



8

8

가

2.

[dis-16]

3.

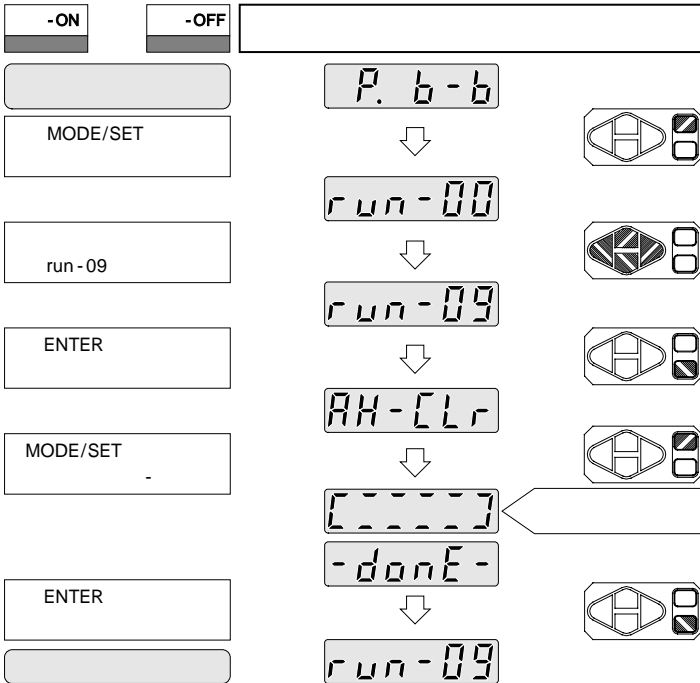

7.10.12

(run-10)



7.9

7.10.13 2

(run-11)

1.



6.6.5



2.

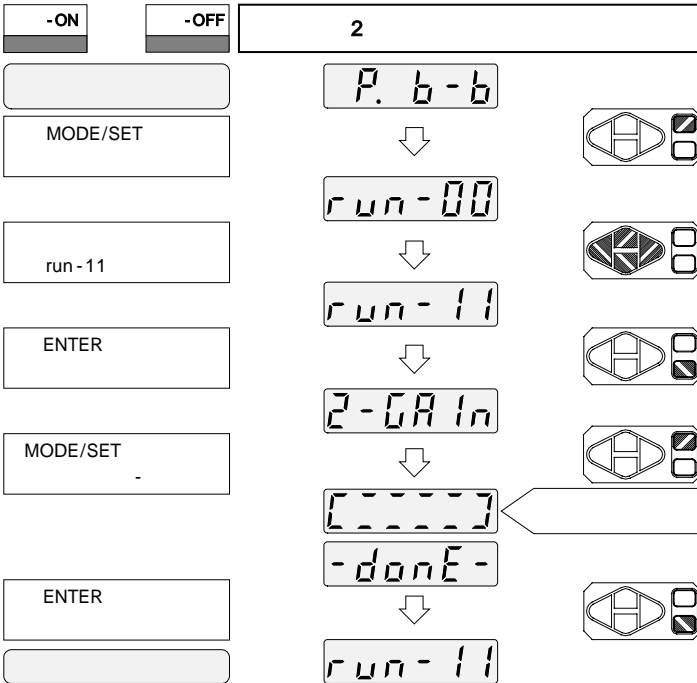

	<p>▶ 6.6.5 </G-SEL> 가</p> <p>▶ 6.6.5</p>
--	--

7.10.14

(run-12)

1.



Pr-0.00	()	Pr-0.05~ Pr-0.11	
Pr-0.01		Pr-3.01~ Pr-3.04	
Pr-0.04		Pr-4.01, Pr-4.02	
		Pr-4.05	

2.

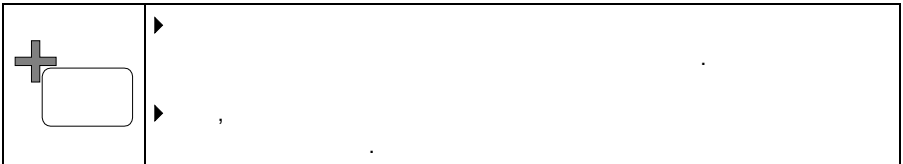
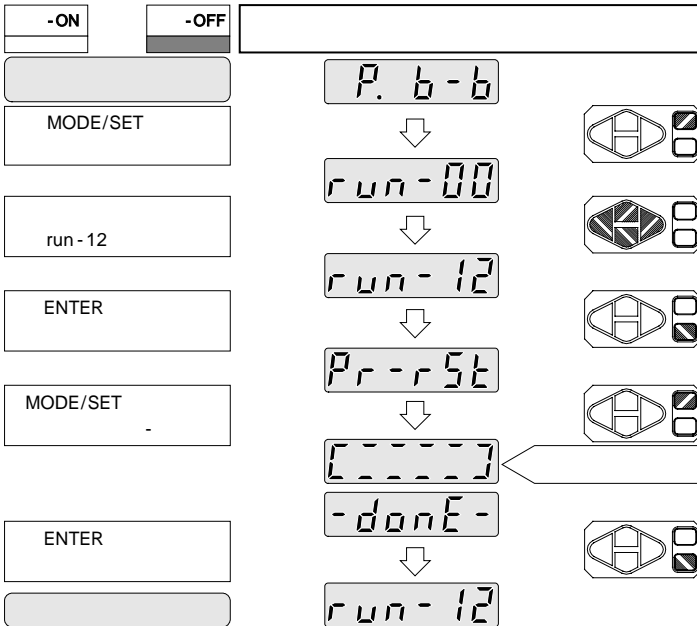

7.11

7.11.1

d 15-00		[rpm]
d 15-01		[rpm]
d 15-02		[rpm]
d 15-03		[%]
d 15-04		[pulse]
d 15-05		[pulse]
<p>▶ (dIS-04, dIS-05) (5 , 10)</p>		
d 15-06		[pulse]
d 15-07		[kpps]
d 15-08		[°]
d 15-09		[°]
d 15-10		[%]
d 15-11	DC Link	[V]
d 15-12		-

d 15-13		[mV]
d 15-14		[mV]
d 15-15		

가 ON 가

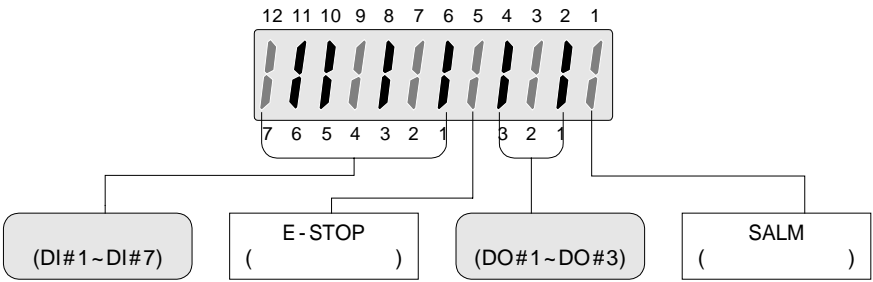

d 15-16	8	
---------	---	--

1
 ▶ 8 가 (8) 1 8
 ▶ 8.2

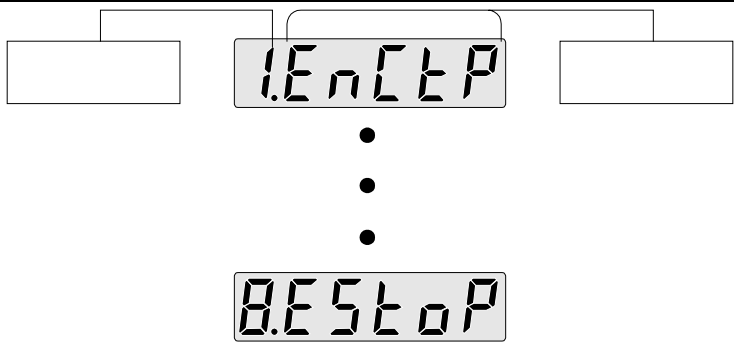

d 15-17		
---------	--	--



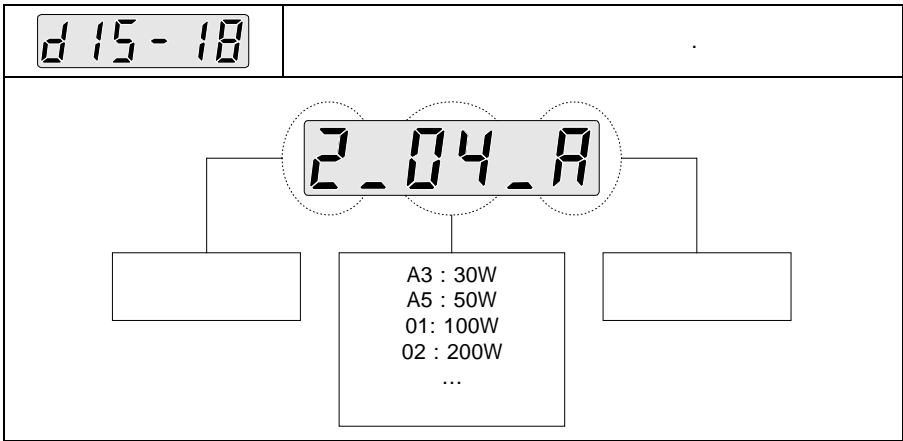

7.11.2

- ▶
- ▶
- ▶ (dis - 16)

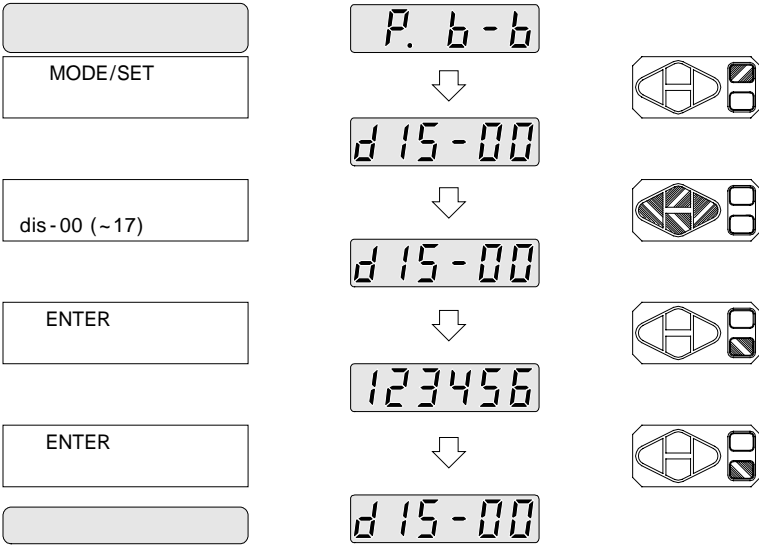

8.1	198
8.1.1	198
8.1.2	198
8.1.3	199
8.1.4	(7.9.3)	199
8.2	200
8.2.1	200
8.2.2	202
8.2.3 A/S	209

8.1

8.1.1

(Brush)

	1	500[V] 10[MΩ]	10[MΩ]
OIL SEAL	5000	OIL SEAL	OIL SEAL
	20000 (5)		
A/S			

8.1.2

(1)

	1		
	1		
	1		
A/S			

8.1.3

가

	3	: 30 : 80[%] 가 : 20 /
	3 ()	
	3	
	2	
DB	2	
FAN	2	
	4~5	
	10	

8.1.4

(7.9.3)



7.9.3

8.2

27가

1. :
2. :



8.2.1

가

- 1.



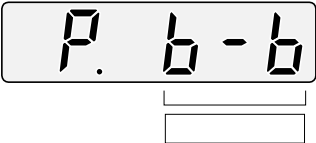

	7- 3 가,
---	------------

- 2.



6가

	
	3.2[V]
	7.9

	
Q Type 가	32768 (A, H, J Type)
4096)	
	7.9

	
	가
	가 (2°)

	E.rEGoL	
		가

	E.oFFSEt	
	(run-07)	가
	±5[%]	
	 <input type="text"/>	가

	E.CAbLE	

	E.InSol	
	(), (), ()	0.5[sec]
	4.2	가-

	E.CoNoL	
		~ [sec]
	4.2	가-

	E.rEGoL	
		가
		[Pr-5.11]

	E.0HEAT	
	±10[°C]가	55[°C] 가 95
	2	55[°C]

	E.EnCTP	TYPE
	[Pr-0.01]	

	E.EnCoP	
		가

	E.Ab5CE	

	E.Ab5bE	
	가	2.7[V]
		7.10.10

	E.Ab5o5	
	가	가
	가 (OFF/ON)	

	E.Ab5nE	
	가	가
	가 (OFF/ON)	

EEnCPE	
	EEPROM

E.oUUtG	
	가
	가

EUdUtG	
	가

EARcOFF	
	() [Pr-5.10]

E.oU5Pd	
	가 () 가 [Pr-2.00], [Pr-4.00]

EPo5Er	
	가 [Pr-5.09]
6	가

	E.ovPUL	
		가
	: 900[kpps]	: 300[kpps]

	E.EStoP	
		(E-STOP) 가
		(E-STOP)

	E.CPUFt	CPU
	CPU	

	E.o0CtL	
		가 가

	E.SErCE	

	E.CHSUM	
		7.10.14

	E.rAnGE	
		7.10.14

	EFLASH	
	7.10.14	

	ECUDEF	

	EUNDEF	
	()	

4.

, CN1
 . CN1 45,46 (SALM +/-)
 . 37~39 (AL1~AL3)

CN1	
SALM +/-	
AL1~AL3	3 7가
7.11	[dis-15]

			SLAM			
				AL1	AL2	AL3
1	E.SHORT		0	1	0	0
	E.IPMFT		0			
	E.OVCUR		0			
	E.REGOC		0			
	E.OFSET		0			
2	E.CABLE		0	0	1	0
	E.INSOL		0			
	E.CONOL		0			
	E.REGOL		0			
	E.OHEAT		0			
3	E.ENCTP	TYPE	0	1	1	0
	E.ENCOP		0			
	E.ABSCE		0			
	E.ABSBE		0			
	E.ABSOS		0			
	E.ABSMT		0			
	E.ENCPE		0			
4	E.OVVTG		0	0	0	1
	E.UDVTG		0			
	E.ACOFF		0			
5	E.OVSPD		0	1	0	1
	E.POSER		0			
	E.OVPUL		0			
	E.ESTOP		0			
	E.CPUFT	CPU	0			
	E.OOCTL		0			
6	E.SERCE		0	0	1	1
	E.CHSUM		0			
	E.RANGE		0			
	E.FLASH		0			
	E.CUMER		0			
7	E.UNDEF		0	1	1	1
	E.SETUP		0			

8.2.3 A/S

- ▶ 가
- ▶ 가 A/S

▶ 가		
	-ON	5.11) (Pr-3.5
	OFF	P-OT, N-OT ON
▶ 가 가 가		[Pr-1.00] [Pr-1.02]
▶ '0' 가		'0'
▶ TYPE		[Pr-0.01]
		3
▶ 가	가	()
▶ 가	가	(.55°C)

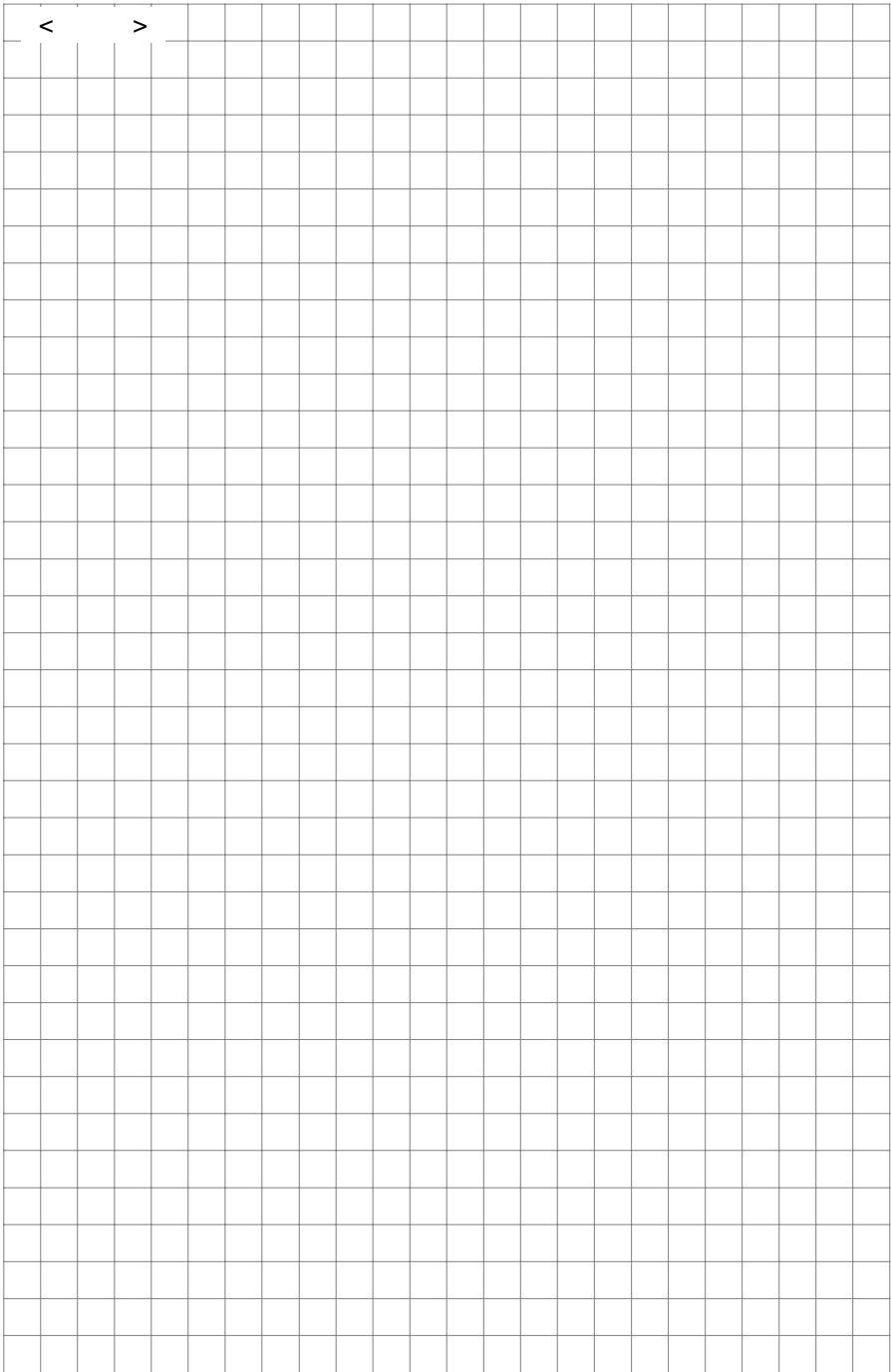



A.1	214
A.1.1	0	214
A.1.2	1	220
A.1.3	2	225
A.1.4	3	230
A.1.5	4	234
A.1.6	5	237
A.1.7	244
A.1.8	245
A.2	249
A.2.1	249
A.2.2	250
A.3	253
A.3.1 CSM	253
A.3.2 CSMT	(17bit)	257
A.3.3 CSME	(17bit)	260
A.3.4 CSMW	(17bit)	262
A.3.5 CSMQ	264
A.3.6 CSMZ	266
A.3.7 CSMD	268
A.3.8 CSMF	271
A.3.9 CSMH	274
A.3.10 CSMS	277
A.3.11 CSMK	280
A.4	283
A.4.1 CSM	284
A.4.2 CSM	286
A.4.3 CSMT	(17bit)	289
A.4.4 CSMZ	291
A.4.5 CSME	(17bit)	292
A.4.6 CSMQ	293
A.4.7 CSMW	(17bit)	294
A.4.8 CSMD/F/H/K/S	295
A.5	300
A.5.1	3	300
A.5.2	303
A.5.3 I/O	308
A.5.4	309

A.5.5	309
A.5.6	310
A.6	313
A.6.1	ROLL	313
A.6.2	TIMINGBELT3	16
A.6.3	BALLSCREW	318
A.6.4	BALLSCREW	320
A.6.5	RACK& PINION	322
A.6.6	324
A.7	326

A.1

A.1	214
A.1.1	0.....	214
A.1.2	1.....	220
A.1.3	2.....	225
A.1.4	3.....	230
A.1.5	4.....	234
A.1.6	5.....	237
A.1.7	244
A.1.8	245

A.1

A.1.1 0

0 [Pr-0.00] ~ [Pr-0.13]

Pr-0.00 ()

▶			
▶ / / /			
▶ </C-SEL> 가		</C-SEL> , 가	
		ON, /OFF	
---		P	
--S-			
-E--			
[---			
		</C-SEL>	
		</C-SEL> = OFF	</C-SEL> = ON
--SP		--SP	--SP
-ES-		ES-	-ES
-E-P		E-P	-EP
[--P		[E-P	[E-P
[S-		[S-	[S
[E--		[E--	[E--
ALL		-OFF > > 가 >	
4.3			

Pr-0.02 8.80000	4가
-----------------	----

1	8.80000	(DB)
▶ DB(Dynamic Brake)		
▶ - OFF		
0	DB	DB
1	DB	DB
2	DB	
	ALL	- OFF > >
7.1.4		

2	8.80000	
▶ (Over-Travel)		
0	[Pr-4.05]	
1	[Pr-0.02]	DB
	ALL	- OFF > >
7.1.3		

3	8.80000	
▶		
0	CW	
1	CCW	
	ALL	- OFF > >
7.3		

4	8.80000	
▶ AC, DC		
0	AC	(L1, L2, L3) AC
1	DC	(P2, N) DC
	ALL	- OFF > >
4.3.4		

Pr-0.03 8.8.0700	
------------------	--

3	8.8.0000	
▶		
2 ~ 9	(*100[rpm])가	
	ALL	-OFF > >
6.3.2		

4	8.8.7000	
▶ -		
0~9	'0' -	
	ALL	-OFF > >
6.3.3		

Pr-0.04	
---------	--

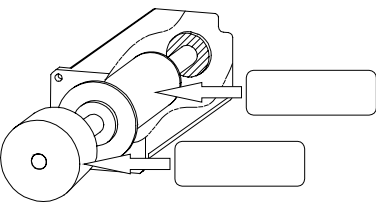
	<p style="text-align: right;">(Rotor)</p> <p style="text-align: right;">(Rotor) 3[gf.cm.s²]</p> <p style="text-align: right;">30[gf.cm.s²]</p> <p style="text-align: right;">10[]가</p> <p style="text-align: right;">(Rotor) (Inertia)</p>
--	---

				>
0.00~60.00	1.00	[]		ALL
▶ [Pr-1.00] 2가 ([Pr-1.01], [Pr-1.02])				
▶ - [run-01] 가				
[Pr-0.04]				
6.1.3				

Pr - 0.05 ~ Pr - 0.09

	8	7	6	5	4	3	2	1	0
		DI#7	DI#6	DI#5	DI#4	DI#3	DI#2	DI#1	
CN1		9	8	7	6	5	4	3	
▶ '0' '1~8' ▶ CN1 5 가 '3' ▶ '0' ▶ 가 ON '8' ▶ 7- 가									

	7-				
		000	0	0	0
1	Pr - 0.05	</P-CON> 4	<N-OT> 3	<P-OT> 2	</SV-ON> 1
2	Pr - 0.06	</C-SEL>	</P-TL> 7	</N-TL> 6	</A-RST> 5
3	Pr - 0.07	</C-SP3>	</C-SP2>	</C-SP1>	</C-DIR>
4	Pr - 0.08	Reserved	</G-SEL>	</INHIB>	</Z-CLP>
5	Pr - 0.09	Reserved	Reserved	Reserved	</ABS-DT>

Pr - 0.05		[Pr-0.05]	'7'
8.8.78.8.8		</P-CON> DI#7	CN1
ALL		>	가 >
		5.1	

Pr-0.10 Pr-0.11

	3	2	1	0
	DO#3	DO#2	DO#1	
CN1	47, 48	43, 44	41, 42	

▶ '0'
▶ 7-가

	7-				
		000	0	0	0
1	Pr-0.10	</V-COM>	</BK> 3	</TG-ON> 2	</P-COM> 1
2	Pr-0.11	</WARN>	</NEAR>	</ V-LMT>	</T-LMT>

Pr-0.11	[Pr-0.11]	'3'
8.838.8.8	</WARN> 47,48	, CN1
ALL	<-OFF >	> 가 >
	5.1	

Pr-0.12 ID

				>
1~255	1	-		ALL
▶ ID				
▶ RS-232	1			

Pr-0.13
▶ A/S

A.1.2

1

1	[Pr-1.00] ~ [Pr-1.13]
---	-----------------------

Pr - 1.00	
-----------	--

				>
0~50	5	10[Hz]		ALL
▶ / / .				
▶ (, .)				
▶				
▶ (bandwidth)				
▶ [Pr-0.04]				
▶ . [Pr-1.01], [Pr-1.02], [Pr-1.03], [Pr-1.04], [Pr-1.05]				
				6

Pr - 1.01	
-----------	--

				>
0~10000	100	[Nms]		P S C
▶				
▶ [Pr-0.04] [Pr-1.00]				
				6

Pr - 1.02	
-----------	--

				>
0~60000	100	[Nms ²]		P S C
▶				
▶ 가				
▶ [Pr-0.04] [Pr-1.00]				
				6

Pr - 103				
----------	--	--	--	--

				>
0~700	50	[Hz]		P
▶				
▶				
▶	[Pr-1.00]			
	6			

Pr - 104				
----------	--	--	--	--

				-OFF > >
0~10000	1000	[Hz]		ALL
▶				
▶	[Pr-1.00]			
	6			

Pr - 105				
----------	--	--	--	--

				>
0~10000	1000	[Hz]		ALL
▶				
▶	[Pr-1.00]			
	6			

Pr - 106				
----------	--	--	--	--

				>
0~2500	0	[Hz]		ALL
▶				
	6			

Pr - 1.07				
				-OFF > >
0~10000	10000	[Hz]		ALL
▶ ▶ '0' ▶ ▶				
	6			

Pr - 1.08				FF
				>
0~100	0	[%]		ALL
▶ 가 가 ▶				
	6			

Pr - 1.09				FF
				>
0~2500	200	[Hz]		ALL
▶ FF [Pr-1.08] '0' ▶ [Pr-1.08] '0' '0'				
	6			

Pr - 1.10	8.8.8.8.1	P
-----------	-----------	---

▶ (PI) (P)	
(Over shoot) .	
가 .	
0	P/PI .
1	PI [Pr-1.11] [%] , 가 P
2	가 PI [Pr-1.11] P [rpm] ,
3	가 [Pr-1.11] [pulse] , 가 PI P .
	ALL -OFF > >
	6.6.3

Pr - 1.11	P
-----------	---

				>
0~3000	100	[가]		ALL
▶ [Pr-1.10] 가 .				
▶ [%], [rpm], [Pulse],				
▶ ,				
▶ 가 PI P .				
				6.6.3

Pr - 1.12	
-----------	--

				>
0~450	0	[rpm]		ALL
▶ 가 [Pr-1.13]				
(Bias) 가 .				
				6.6.2

Pr - 1.13	
-----------	--

				>
0~250	10	[pulse]		ALL
▶ (Bias) , 가 [Pr - 1.12]				
	6.6.2			

A.1.3

2

2	[Pr-2.00] ~ [Pr-2.13]
---	-----------------------

Pr-2.00	
---------	--

				-OFF > >
10.0~2000.0	500.0	[rpm/V]		S
▶ (CN1 19, 20) 1[V] [rpm]				
▶ [rpm] = (Pr-2.00) [rpm/V] x [V]				
5.3 , 7.6				

Pr-2.01	
---------	--

				>
0~5000	500	[rpm]		ALL
▶ (run-00)				
▶ Homing(run-02)				
4.4 , 7.10.2				

Pr-2.02	가
Pr-2.03	

				>
0~60000	0	[msec]		ALL
▶	가-	S-		.
▶	'0'	가		.
▶	'0'			.

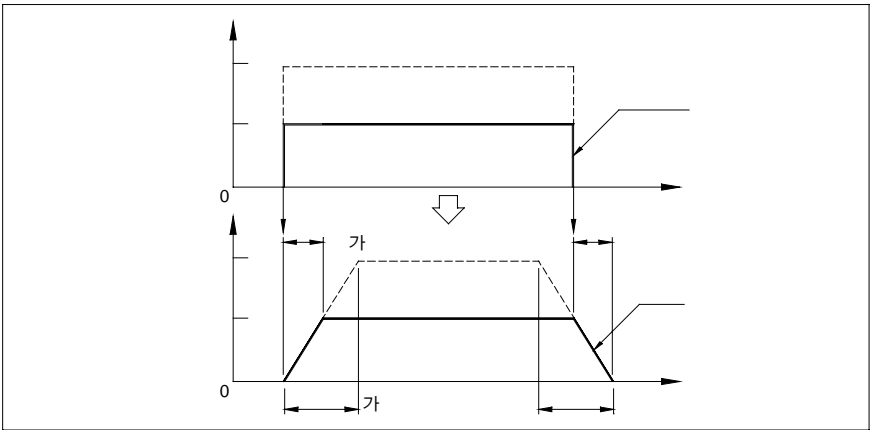

7.5

Pr-204

S-

>

0~5000

0

[msec]

ALL

▶

S-

▶ 가-

0'

S-

0'

가-

S-

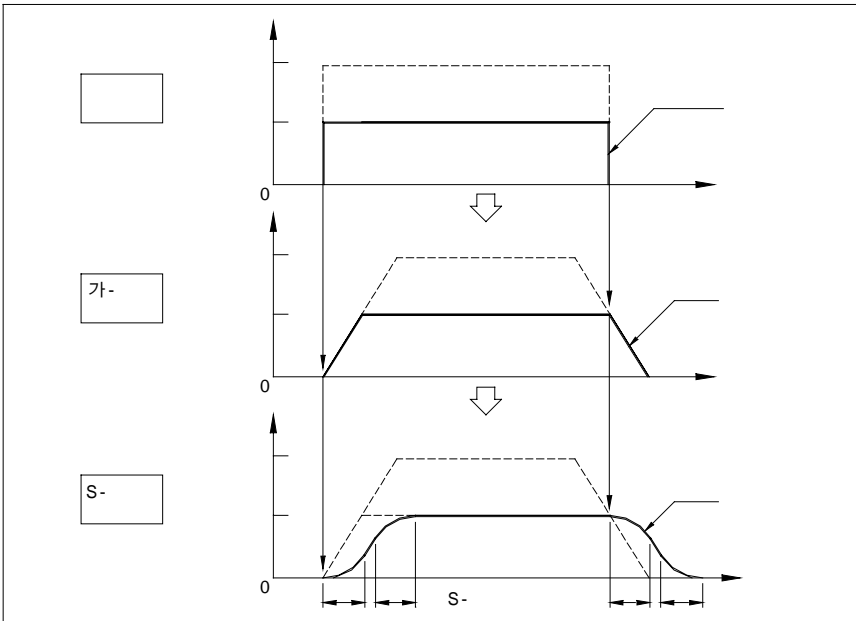

7.5

Pr-205 ~ Pr-2.11

				>
-5000~5000	100 ~700	[rpm]		C
▶ ▶ ▶ </C-SP1>, </C-SP2>, </C-SP3> ▶ </C-DIR> ▶ 가				

		</C-SP3>	</C-SP2>	</C-SP1>
	0[rpm]	0	0	0
1	Pr-205 880100	0	0	1
2	Pr-206 880200	0	1	0
3	Pr-207 880300	0	1	1
4	Pr-208 880400	1	0	0
5	Pr-209 880500	1	0	1
6	Pr-2.10 880600	1	1	0
7	Pr-2.11 880700	1	1	1
	 <input type="text"/> <input type="text"/> [rpm]			
	5.5			

Pr-2.12	
---------	--

				-OFF > >
1~5000	5000	[rpm]		ALL
▶ ▶ . [Pr-2.13] ▶ , 가 ▶ "OSC"가 ▶				
	7.6			

Pr-2.13	8.8.8.8.0	
---------	-----------	--

▶				
0				
1	[Pr-2.12]			
2	()			
3	[Pr-2.12]			
	ALL		-OFF > >	
	7.6			

3	[Pr-3.00] ~ [Pr-3.04]
---	-----------------------

Pr - 3.00	8.8.8.8.0	
-----------	-----------	--

▶				
CW + CCW			-	0
+			-	2
A + B			1	4
			2	5
			4	6
CW + CCW			-	1
+			-	3
	P		-OFF >	>
5.2				

Pr - 3.00 8.8.8.08



▶	900[kpps].		
▶	300[kpps]		
▶	가		
▶	(E.ovPUL)		
0			
1			
	P		- OFF > >
	5.2		

Pr - 3.00 8.8.8.08

▶			
0	A 90°		
1	B 90°		
	ALL		- OFF > >
	7.7		

Pr - 3.00	8.808.8.8	PCLR
-----------	-----------	------

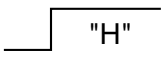
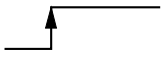
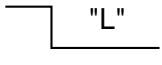
가 가 '0' 가
(PCLR) CN1 (15, 16)
가 '0' (trigger)

0	H H	(0)	
1		(rising edge)	
2	L L	(0)	
3		(falling edge)	
	P		OFF > >
			5.2

Pr - 3.01	()
Pr - 3.02	()

				-OFF > >
1~65535	2048	[pulse]		P
▶				
▶	1	x	x 4	(Pr-3.02)
▶	= 1 / ([1] x [] x 4)			
				5.2

Pr-3.03	()
Pr-3.04	()

				-OFF > >
1~65535	2048	[pluse]		ALL

- ▶ 1 (EA+, EA-, EB+, EB-)
- ▶ [Pr-3.03] .
- ▶ 1 .
- ▶ [Pr-3.04] .
- ▶ 1 가 .
- ▶ [Pr-3.03] ≤ [Pr-3.04] 가 .

Pr-3.03				
Pr-3.04	X 1	=		

	7.7
--	-----

A.1.5

4

4	[Pr-4.00] ~ [Pr-4.06]
---	-----------------------

Pr-4.00	
---------	--

				-OFF > >
0.0~100.0	33.3	[% /V]		ALL
▶ (CN1 21, 22) 1[V] [%]				
▶ [%] = [Pr-4.00] [% /V] x [V]				
				5.4

Pr-4.01	
Pr-4.02	

				>
0~300	300	[%]		ALL
▶ 가 , . ()				
				5.4

Pr - 4.03	
Pr - 4.04	

				>
0~300	100	[%]		ALL

▶ 가 [Pr-4.01], [Pr-4.02] </P-TL>, </N-TL> 가
 [Pr-4.03], [Pr-4.04]
 ▶ [Pr-4.01] [Pr-4.02] </P-TL>,
 </N-TL>

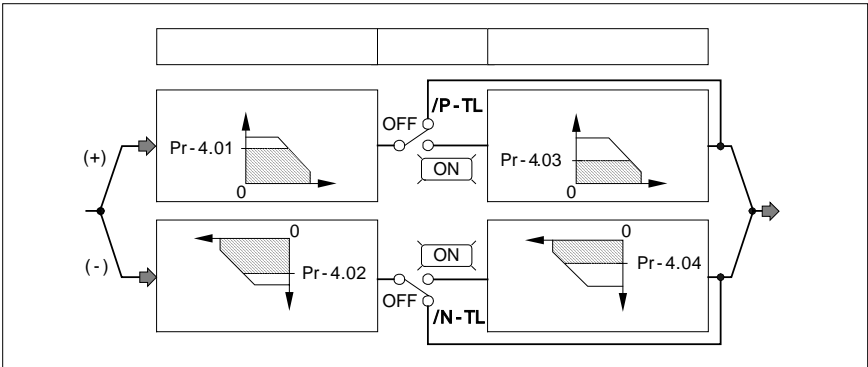

5.4

Pr - 4.05	
-----------	--

				>
0~300	300	[%]		ALL

▶ 가 (<P-OT>, <N-OT>)
 가
 ▶

5.4

Pr - 4.06

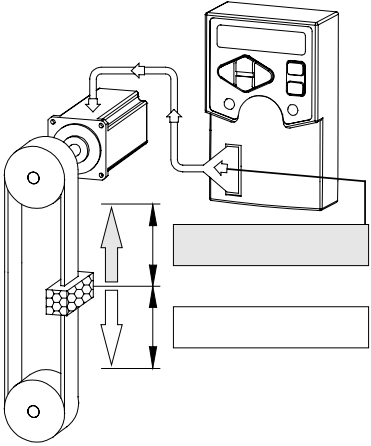
				>
-100~100	0	[%]		ALL
			▶	가 -ON
			▶	가 , -ON, -OFF 가
			▶	가 , 가
▶				-ON 가 가
▶				가
▶				, 가
6.6				

A.1.6

5

5	가	[Pr-5.00] ~ [Pr-5.13]
---	---	-----------------------

Pr - 5.00

				>
0~250	10	[pulse]		P
</P-COM>				
() ()				
()				
가 가 100[pps]				
</P-COM>				
5.2				

Pr - 5.01

				>
0~250	20	[pulse]		P
</NEAR>				
() ()				
()				
가 가 100[pps]				
</ NEAR >가				

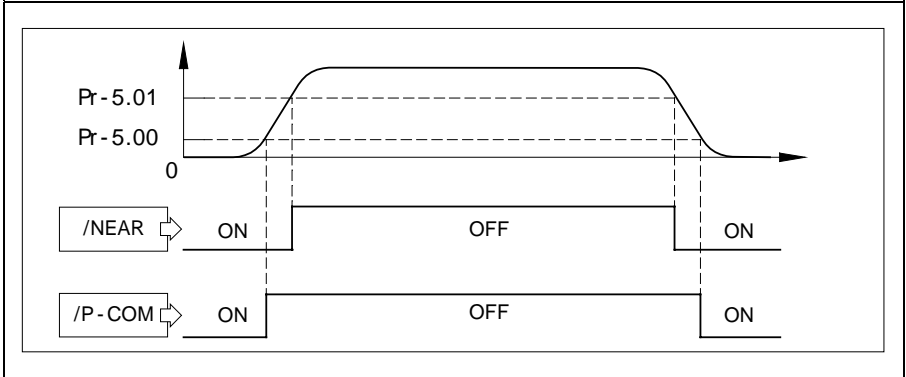

				5.2
Pr - 5.02				

				>
0~1000	10	[rpm]		S

▶ </V-COM>
 ▶
 ▶ 가 </ V-COM>
 </V-COM>

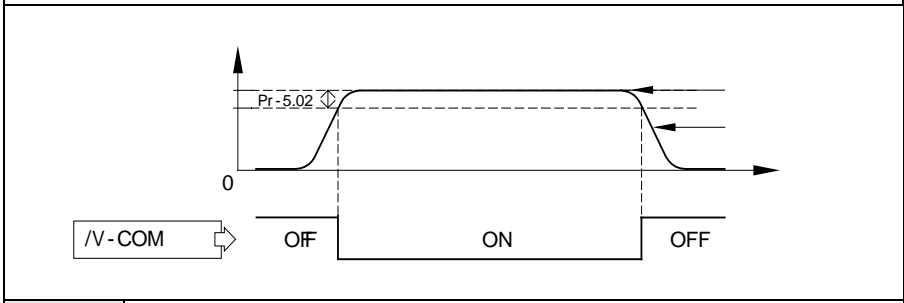
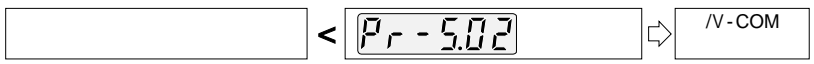

5.3

				Pr - 5.03
--	--	--	--	-----------

				>
1~5000	20	[rpm]		ALL

▶ </TG-ON>
 ▶ 가 </TG-ON> 가
 ▶ 가

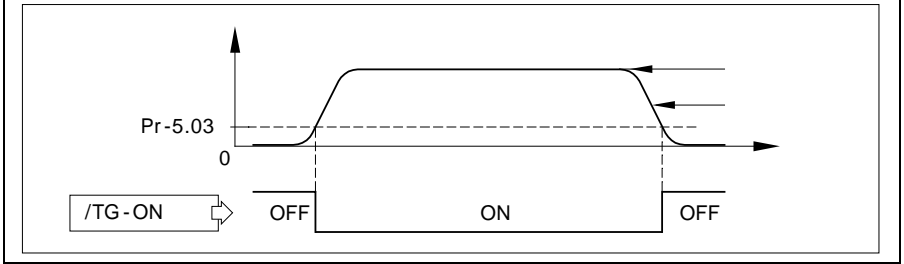

Pr-5.04

>

0~5000

0

[rpm]

S

- ▶ '0' 가 (Zero-Clamp)
- ▶ 가
- ▶ 가 </Z-CLP>
- ▶ 가
- ▶ </Z-CLP> Pr-5.04 '0'
- ▶ </Z-CLP>

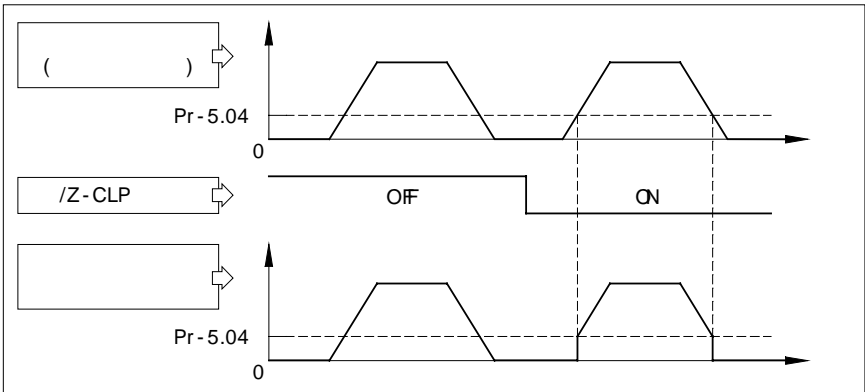

Pr - 5.05	
------------------	--

				-OFF > >
0~1000	0	10[ms]		ALL

▶ 가 , 가 , -ON () 가 가 , 가 가 -ON 가 , 가 가 -ON 가

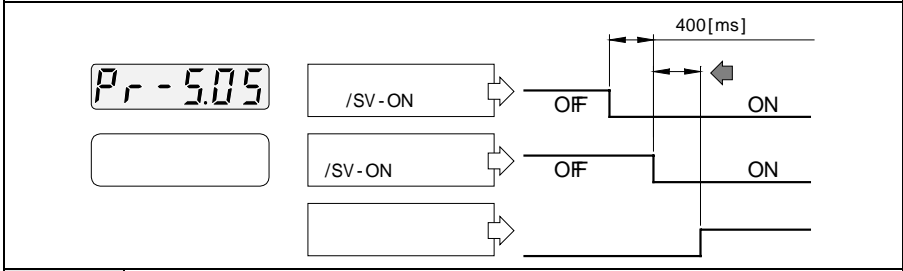

7.2

Pr - 5.06	-OFF
------------------	------

				-OFF > >
0~1000	0	10[ms]		ALL

▶ 가 -OFF , -OFF

▶ -OFF ,

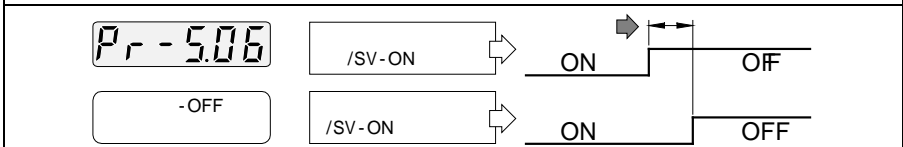

7.2

Pr-5.07

				OFF > >
0~1000	50	10[ms]		ALL

가 .
가 .

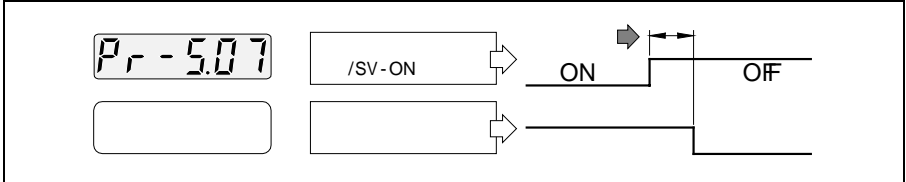

7.2

Pr-5.08

				-OFF > >
0~1000	100	[rpm]		ALL

가 .

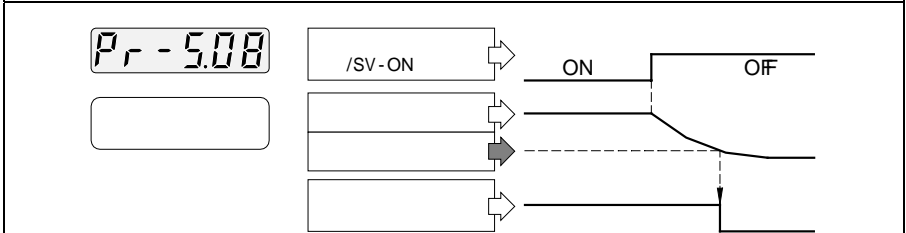

7.2

Pr - 5.09	
-----------	--

				>
0~65535	20480	[pulse]		P
▶ 가				
(E.PoSEr)				
				5.2

Pr - 5.10	
-----------	--

				-OFF > >
20~1000	20	[ms]		ALL
▶ (temporary power down)				
▶ (E.AcoFF)				
▶ [Pr-0.02] DC				
				4.3

Pr - 5.11	
-----------	--

				-OFF > >
0~1500		[W]		ALL
▶ 가				
▶ (E.rEGOL)				
				7.4

	[W]
200[W]	-
400[W]	15

	[W]
1[kW]	70
1.5[kW]	70

Pr - 5.12 0-0500				CH1
------------------	--	--	--	-----

				>
0-0001 ~ 6-2500	0-0500			ALL
▶ 가				
7.8				

Pr - 5.13 3-0500				CH2
------------------	--	--	--	-----







				>
0-0001 ~ 6-2500	3-0500			ALL

	No.			
	0		1~500	[rpm]
	1		1~30	[%]
	2		1~5000	[pulse]
	3	Feedback	1~500	[rpm]
	4	Feedback	1~30	[%]
	5	Feedback	1~5000	[pulse]
	6		1~2500	[pulse]
7.8				

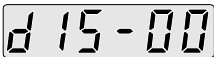
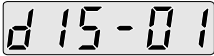
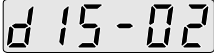
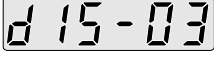
A.1.7

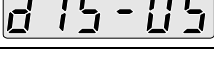
run-00	
run-01	-
run-02	
run-03	
run-04	
run-05	
run-06	
run-07	
run-08	
run-09	
run-10	
run-11	2
run-12	

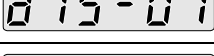
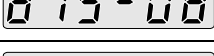
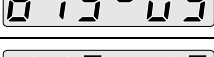
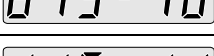
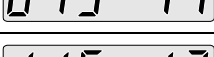
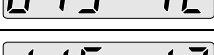
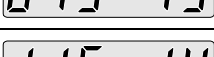
A.1.8

		[rpm]
		[rpm]
		[rpm]
		[%]
		[pulse]
		[pulse]
		[pulse]
		[kpps]
		[°]
		[°]
		[%]
	DC Link	[V]
		-
		[mV]
		[mV]

d 15 - 15

12 11 10 9 8 7 6 5 4 3 2 1

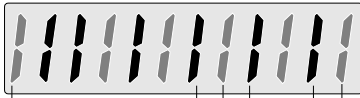

(DI#1~DI#7)

E-STOP

()

(DO#1~DO#3)

SALM

()

d 15 - 16

8

1

8

가

(8)

1

8

8.2

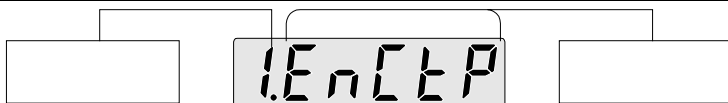

0.E S t o P

d 15 - 17



u E r 1.0 2

d 15 - 18

2_04_A

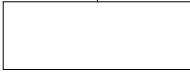

A3 : 30W
A5 : 50W
01 : 100W
02 : 200W
...

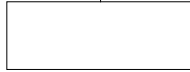

A.2

A.2	249
A.2.1	249
A.2.2	250

A.2

A.2.1

CSD3-A3BX1(P)	30[W]	200-230[V], 50/60[Hz]	0.9[kg]
CSD3-A5BX1(P)	50[W]		
CSD3-01BX1(P)	100[W]		
CSD3-02BX1(P)	200[W]		

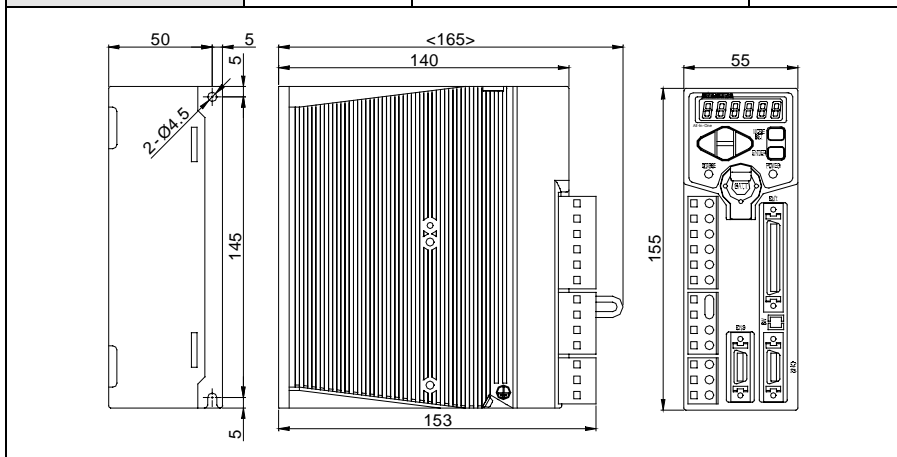

CSD3-04BX1(P)	400[W]	200-230[V], 50/60[Hz]	1.2[kg]

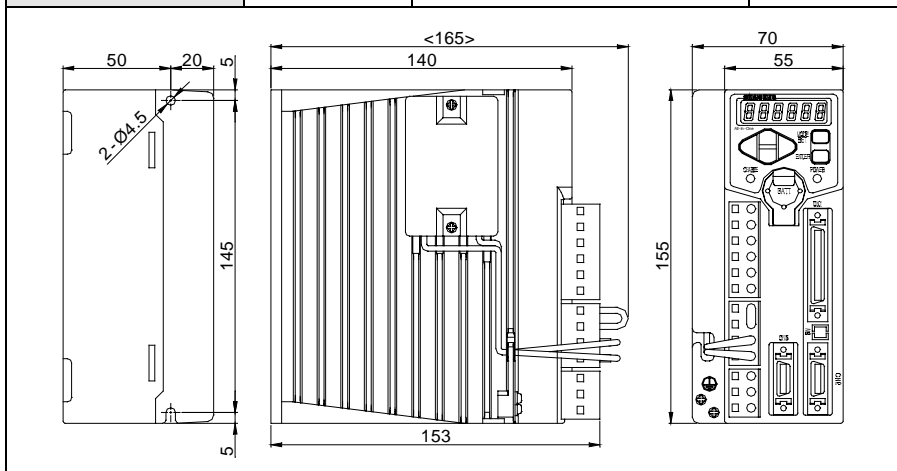

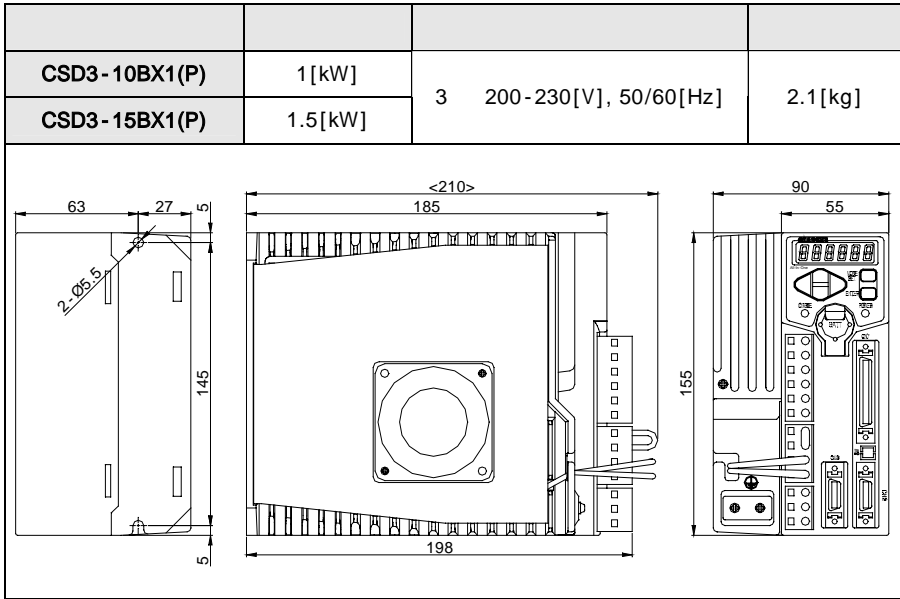

A.2.2

		IPM	PWM
		2048/2500/5000/10000 P/R(Incremental/Absolute Type) 131072 P/R(17bit Serial Incremental/Absolute Type)	
/		0 ~ 55 /90% RH	
/		-25 ~ 80 /90% RH	
		(Base Mounted Type)	
勤		1:5000	
		0~10%	±0.01%
		170~153VAC	0%
		25±25	±0.1%
		550Hz	
		±2%	
	가	0~60sec	

		Feedforward	0~100%
			0~250[pulse]
			CW+CCW + A +B (90° 2)
		Type	Line Drive : 2.8~3.7V Open Collector : 24, 12, 5V
			Line Drive : 900[kpps] Open Collector : 250[kpps]
			()
	•		±10VDC(16Bit A/D)
			8.3MΩ
			1 μs
	I/O		Line Drive : A, B, Z , Open Collector : Z
			/ , , , / P/PI , , , ,
		, , , , , ,	
			H/W
	Dynamic Brake		OFF ,
			400W
			, , , CPU , , ,
	Monitoring		/ / 2CH D/A ,
			SERCOS, DeviceNet : RS-485 : RS-232C : PC/PDA

A.2

A.2	249
A.2.1	249
A.2.2	250

A.2

A.2.1

CSD3-A3BX1(P)	30[W]	200-230[V], 50/60[Hz]	0.9[kg]
CSD3-A5BX1(P)	50[W]		
CSD3-01BX1(P)	100[W]		
CSD3-02BX1(P)	200[W]		

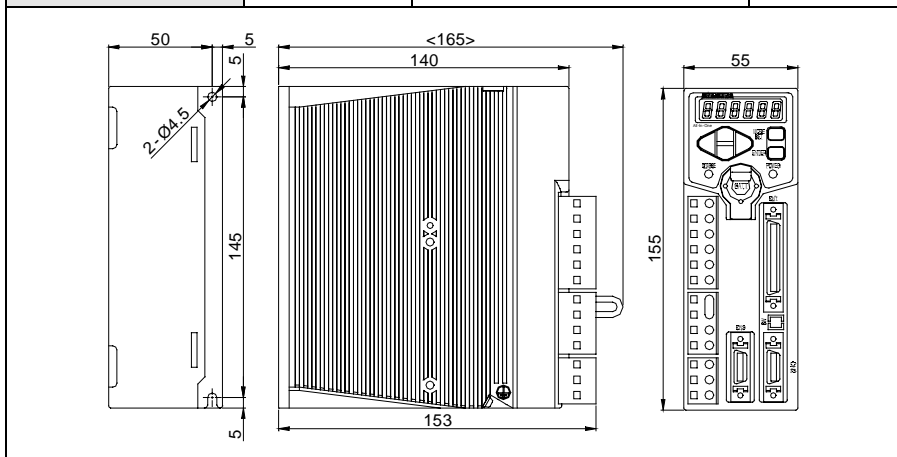

CSD3-04BX1(P)	400[W]	200-230[V], 50/60[Hz]	1.2[kg]

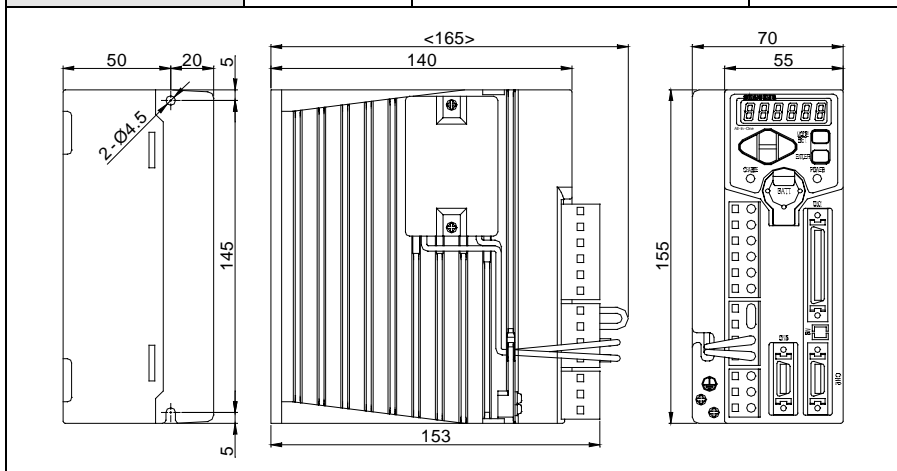

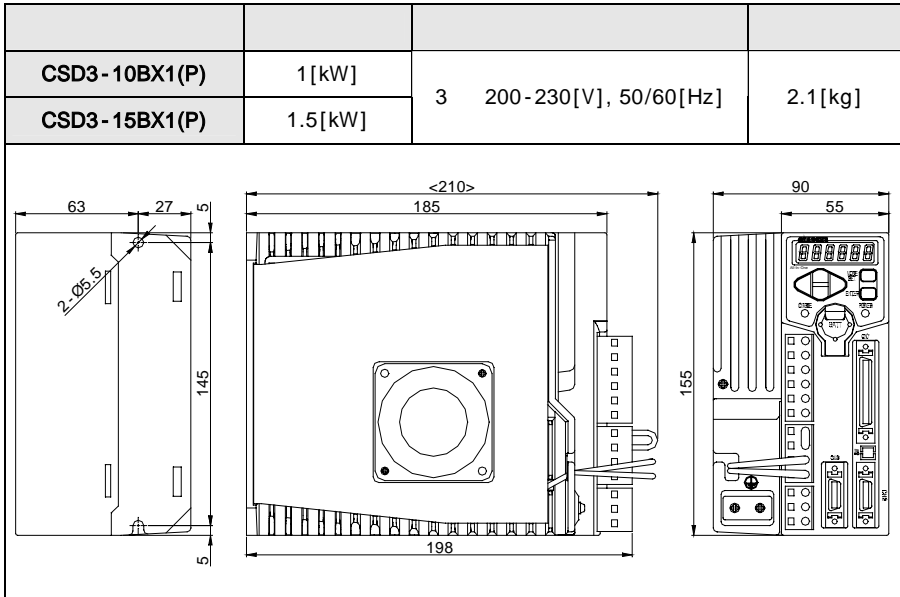

A.2.2

		IPM	PWM
		2048/2500/5000/10000 P/R(Incremental/Absolute Type) 131072 P/R(17bit Serial Incremental/Absolute Type)	
/		0 ~ 55 /90% RH	
/		-25 ~ 80 /90% RH	
		(Base Mounted Type)	
동 가			1:5000
			0~10% ±0.01%
			170~153VAC 0%
			25±25 ±0.1%
			550Hz
			±2%
			0~60sec

		Feedforward	0~100%
			0~250[pulse]
			CW+CCW + A +B (90° 2)
		Type	Line Drive : 2.8~3.7V Open Collector : 24, 12, 5V
			Line Drive : 900[kpps] Open Collector : 250[kpps]
			()
	•		±10VDC(16Bit A/D)
			8.3MΩ
			1 μs
	I/O		Line Drive : A, B, Z , Open Collector : Z
			/ , , , / P/PI , , , ,
		, , , , , ,	
			H/W
	Dynamic Brake		OFF ,
			400W
			, , , CPU , , ,
	Monitoring	/ / 2CH D/A	,
		SERCOS, DeviceNet : RS-485 : RS-232C : PC/PDA	

부 록 A.3 서보 모터 사양

A.3 서보 모터 사양	253
A.3.1 CSM 모터	253
A.3.2 CSMT 모터(17bit 인코더 부착형)	257
A.3.3 CSME 모터(17bit 인코더 부착형)	260
A.3.4 CSMW 모터(17bit 인코더 부착형)	262
A.3.5 CSMQ 모터	264
A.3.6 CSMZ 모터	266
A.3.7 CSMD 모터	268
A.3.8 CSMF 모터	271
A.3.9 CSMH 모터	274
A.3.10 CSMS 모터	277
A.3.11 CSMK 모터	280

A.3 서보 모터 사양

A.3.1 CSM 모터

1. 기본 사양

항 목	사 양	항 목	사 양
결 선 방 식	Y 결선	시 간 정 격	연속사용
동 작 온 도 범 위	0 ~ +40℃	절 연 등 급	B 중
보 존 온 도 범 위	-10 ~ +80℃	절 연 내 압	1500VAC 60sec
절 연 저 항	500VDC 100 MΩ	여 자 방 식	영구 자석
극 수	8 극	취 부 방 법	FLANGE
진 동	15 m/s ²	동 작 습 도	20 ~ 80%

항 목		CSM 모터							
		A3B	A5B	01B	02B	04B	06B	08B	10B
적용 DRIVE	CSD3-__BX1	A3	A5	01	02	04	10	10	10
정격 전압	V	220							
정격 출력	W	30	50	100	200	400	600	800	1000
정격 TORQUE	Kgf·cm N·m	0.97	1.62	3.25	6.5	13	19.5	26	32.5
		0.095	0.16	0.32	0.64	1.27	1.91	2.55	3.19
순시 최대 TORQUE	Kgf·cm N·m	2.9	4.9	9.7	19.5	39	58.5	78	97.5
		0.29	0.48	0.95	1.91	3.82	5.73	7.64	9.55
정격 회전 속도	RPM	3000							
최대 회전 속도	RPM	5000							3500
ROTOR INERTIA	gf·cm·s ² Kg·m ² ·10 ⁻⁴	0.013	0.023	0.043	0.2	0.37	1.02	1.33	1.65
		0.013	0.023	0.042	0.2	0.36	1.00	1.30	1.62
ROTOR INERTIA (BRAKE 부착 시)	gf·cm·s ² Kg·m ² ·10 ⁻⁴	0.021	0.031	0.051	0.29	0.46	1.38	1.69	2.01
		0.021	0.031	0.050	0.29	0.45	1.36	1.66	1.98
POWER RATE	KW/s	7.09	11.2	24.1	20.7	44.8	36.5	49.8	62.7
기계적 시정수	ms	1.3	0.9	0.7		0.5	0.6	0.5	
전기적 시정수	ms	0.9	1.2	1.4	3.5	3.8	6.4	7.3	7.5
축마찰 TORQUE	Kgf·cm MAX	0.3			0.4		1.0		
정격 전류	A(rms)	0.3	0.5	0.9	1.4	2.7	4.2	4.6	4.6
순시 최대 전류	A(rms)	0.9	1.5	2.7	4.2	8.1	12.6	13.8	13.8
축방향 유격	mm MAX	0.04							
허용 THRUST 하중	Kgf MAX	4	4	4	7	7	10		
허용 RADIAL 하중	Kgf MAX	8			20		35		
질 량	Kg	0.3	0.4	0.5	1.1	1.6	2.6	3.2	3.8
회전 방향		U →V →W							
색상		검정							
Oil Seal		옵션사양							

2. 브레이크 사양

항 목		CSM 모터								
		A3B	A5B	01B	02B	04B	06B	08B	10B	
정격전압	V	24								
정마찰 토크	Kgf·cm	3.25		13			26			
소비전력	W	6		8			9			
브레이크 흡인 시간	ms MAX	20		30			50			
브레이크 해제 시간	ms MAX	40		50			80			

3. 속도-토크 곡선

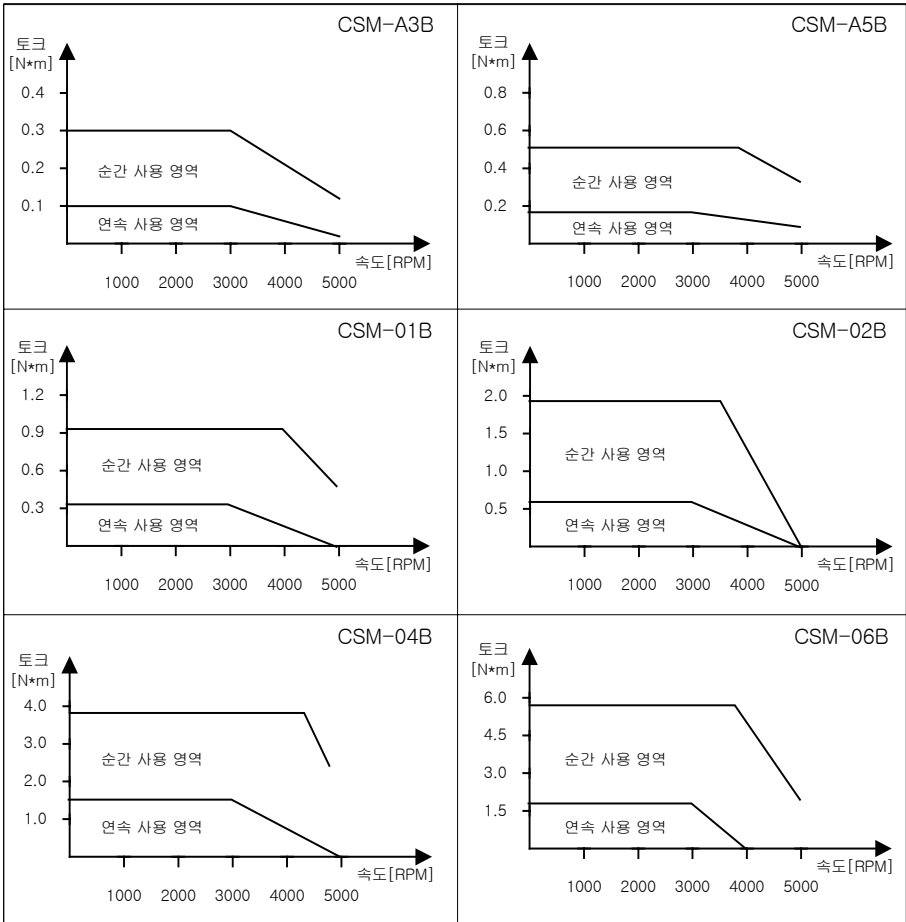

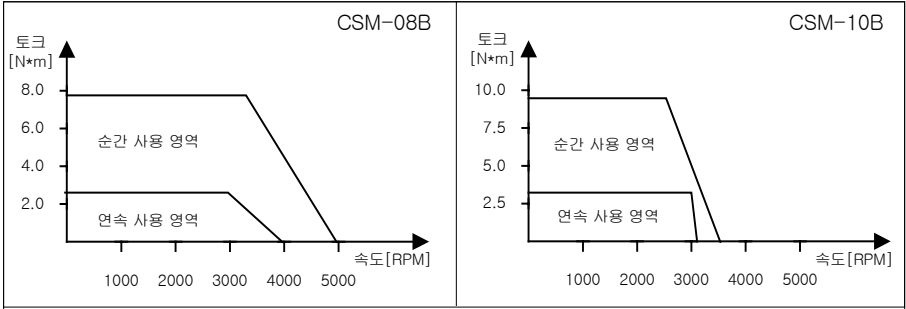

4. 감속기 부착 시 사양

모터 부 사양				감속기 본체 사양								
CSM 모터	출력	회전 속도	정격 토크	백래쉬 사양	감속비	회전 속도	정격 토크	순시 최대 토크	허용 radial 하중	허용 Thrust 하중	입력축에서의 Inertia	감속기 본체 질량
	W	RPM	N·m			RPM	N·m	N·m	N·m	kg		
A5B	50	3000	0.159	B	1/3	1000	0.25	0.78	392	196	0.058	0.58
					1/5	600	0.51	1.47	490	245	0.040	0.58
					1/9	333	0.92	2.74	588	294	0.048	0.73
					1/15	200	1.67	5.00	784	392	0.035	0.73
					1/25	120	2.74	8.33	882	441	0.033	0.73
01B	100	3000	0.318	B	1/3	1000	0.72	2.06	392	196	0.058	0.58
					1/5	600	1.18	3.72	490	245	0.040	0.58
					1/9	333	2.25	6.84	588	294	0.048	0.73
					1/15	200	3.72	11.4	784	392	0.035	0.73
				C	1/25	120	6.27	19.0	1666	833	0.038	1.8
02B	200	3000	0.64	B	1/3	1000	1.47	4.51	392	196	0.145	0.73
					1/5	600	2.65	8.04	490	245	0.125	0.73
				C	1/9	333	3.72	11.3	1176	588	0.400	2.3
					1/15	200	6.27	18.8	1470	735	0.300	2.3
					1/25	120	11.1	33.3	1666	833	0.288	2.3
04B	400	3000	1.27	B	1/3	1000	3.43	10.3	392	196	0.145	0.73
					1/5	600	5.39	16.2	980	490	0.363	1.9
				C	1/9	333	9.51	28.5	1176	588	0.400	2.3
					1/15	200	15.8	47.5	1470	735	0.300	2.3
					D	1/25	120	26.4	79.2	2058	1029	0.300

모터 부 사양				감속기 본체 사양								
CSM 모터	출력	회전 속도	정격 토크	백래쉬 사양	감속비	회전 속도	정격 토크	순시 최대 토크	허용 radial 하중	허용 Thrust 하중	입력축에서의 Inertia	감속기 본체 질량
	W	RPM	N·m			RPM	N·m	N·m	N·m	kg	kg·m ² ·10 ⁻⁴	kg
06B	600	3000	1.91	C	1/3	1000	5.00	15.0	784	392	0.913	2.2
					1/5	600	8.33	24.9	980	490	0.713	2.2
				D	1/9	333	13.9	41.8	1470	735	0.988	3.8
					1/15	200	23.2	69.6	1764	882	0.700	3.8
08B	800	3000	2.55	C	1/3	1000	6.86	20.6	784	392	0.913	2.2
					1/5	600	11.5	34.3	980	490	0.713	2.2
				D	1/9	333	19.5	58.5	1470	735	0.988	3.8
					1/15	200	32.7	97.4	1764	882	0.700	3.8
				E	1/25	120	50.7	152	2650	1320	0.700	7.2

 <div style="border: 1px solid black; border-radius: 10px; padding: 5px; display: inline-block;"> 중요 주의 </div>	<ul style="list-style-type: none"> ▶ 허용 RADIAL 및 TRUST 하중 값은 축의 중앙에서 측정하였습니다. ▶ 백래쉬는 B형의 경우 0.7° , C/D/E의 경우 0.5° 입니다. ▶ 감속기의 사양은 입력 3000RPM, 주위온도 20℃에서 측정된 typical 데이터입니다. ▶ 출력축의 회전방향과 모터의 회전방향이 동일하도록 설계되어 있습니다. ▶ 수명 - 기동 정지 반복 조작 : 10⁵ 회 <ul style="list-style-type: none"> - 정격 토크 연속 운전 : 3000RPM에서 10,000시간 이상
---	--

A.3.2 CSMT 모터(17bit 인코더 부착형)

1. 기본 사양

항 목	사 양	항 목	사 양
결 선 방 식	Y 결선	절 연 등 급	F 종
동 작 온 도 범 위	0 ~ +40℃	절 연 내 압	1500VAC 60sec
보 존 온 도 범 위	-10 ~ +85℃	여 자 방 식	영구 자석
절 연 저 항	500VDC 100 MΩ	취 부 방 법	FLANGE
극 수	8 극	동 작 습 도	20 ~ 85%

항 목		CSMT 모터								
		A3B	A5B	01B	02B	04B	06B	08B	10B	
적용 DRIVE	CSD3-__BX1	A3	A5	01	02	04	10	10	10	
정격 전압	V	220								
정격 출력	W	30	50	100	200	400	600	750	950	
정격 TORQUE	Kgf·cm N·m	0.97 0.095	1.62 0.159	3.25 0.318	6.5 0.64	13.0 1.27	19.5 1.91	24.4 2.39	30.9 3.0	
순시 최대 TORQUE	Kgf·cm N·m	2.9 0.29	4.9 0.48	9.7 0.95	19.5 1.91	39 3.82	58.5 5.73	73 7.16	92.6 9.1	
정격 회전 속도	RPM	3000								
최대 회전 속도	RPM	5000								
ROTOR INERTIA	gf·cm·s ² Kg·m ² ·10 ⁻⁴	0.01 0.01	0.02 0.02	0.03 0.03	0.18 0.18	0.34 0.34	1.00 0.98	1.10 1.08	1.54 1.44	
ROTOR INERTIA (BRAKE 부착 시)	gf·cm·s ² Kg·m ² ·10 ⁻⁴	0.02 0.02	0.03 0.03	0.04 0.04	0.28 0.28	0.44 0.44	1.26 1.52	1.36 1.62	1.80 2.06	
POWER RATE	kW/s	9.2	12.9	34.5	23.0	48.7	37.3	51.3	50.3	
기계적 시정수	ms	1.1	0.9	0.6	0.9	0.7	0.6	0.6	0.7	
전기적 시정수	ms	0.8	1.1	1.6	3.2	3.5	6.0	4.8	5.6	
축마찰 TORQUE	Kgf·cm MAX	0.1		0.3		0.5				
정격 전류	A(rms)	0.3	0.5	1.0	1.7	3.3	4.4	4.9	6.8	
순시 최대 전류	A(rms)	0.9	1.5	3.0	4.9	9.6	12.8	14.1	20.1	
축방향 유격	mm MAX	0.2								
허용 THRUST 하중	Kgf MAX	4			7		10			
허용 RADIAL 하중	Kgf MAX	8			20		35			
질 량 (BRAKE 부착 시)	Kg	0.2 0.4	0.3 0.5	0.4 0.6	0.9 1.3	1.3 1.7	2.1 2.8	2.5 3.2	2.9 3.6	
회전 방향		U →V →W : CCW								
색상		검정								
이리 Seal		옵션사양								

2. 브레이크 사양

항 목		CSMT 모터						
		A3B	A5B	01B	02B	04B	06B	08B
정격전압	V	24 ± 10%						
정마찰 토크	N·m	0.32		1.27		2.55		
	Kgf·cm	3.25		13		26		
회전자 Inertia	$\text{kg} \cdot \text{m}^2 \times 10^{-4}$	0.01		0.10		0.26		
	$\text{gf} \cdot \text{cm} \cdot \text{s}^2$	0.01		0.10		0.26		
소비전력	W	5		9		9.5		
브레이크 흡인 시간	ms MAX	20				50		
브레이크 해제 시간	ms MAX	40		50		80		

3. 속도-토크 곡선

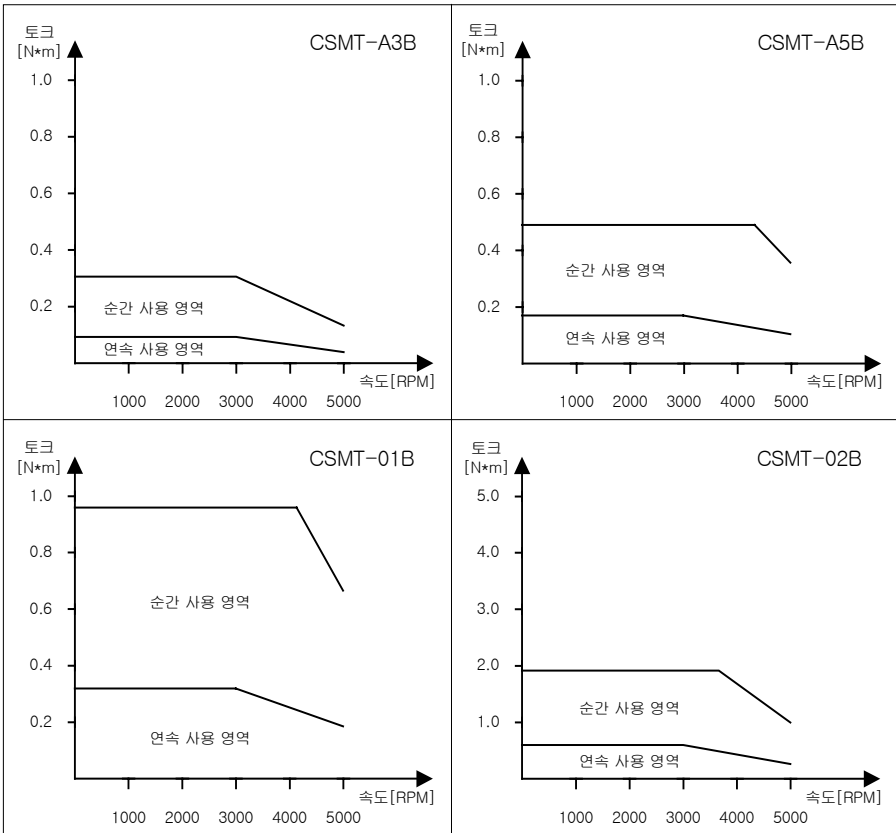

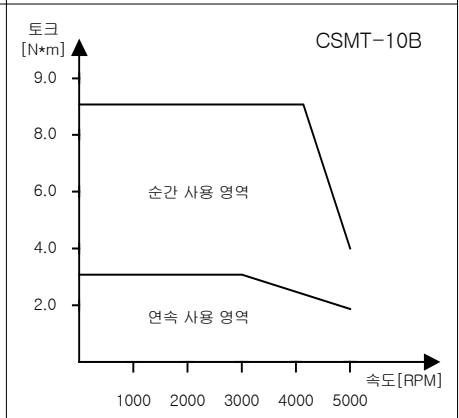
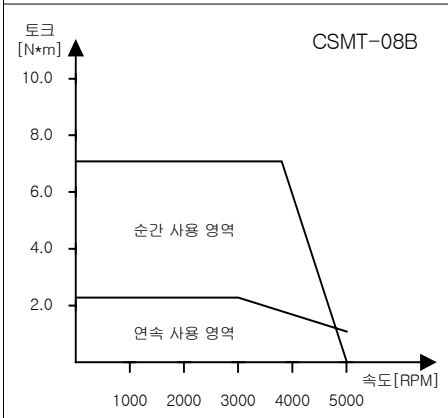
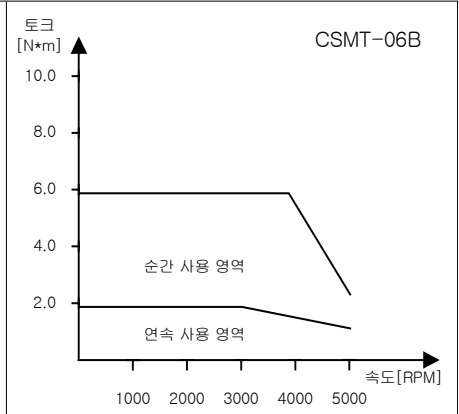
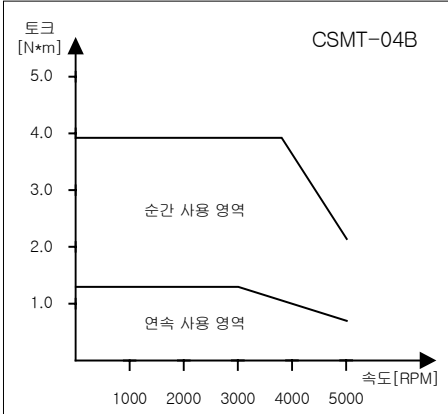

A.3.3 CSME 모터(17bit 인코더 부착형)

1. 기본 사양

항 목	사 양	항 목	사 양
결 선 방 식	Y 결선	시 간 정 격	연속사용
동 작 온 도 범 위	0 ~ +40℃	절 연 등 급	B 중
보 존 온 도 범 위	-20 ~ +80℃	절 연 내 압 브레이크 부착 시	1500VAC 60sec 1200VAC 1sec
절 연 저 항	500VDC 20 MΩ	여 자 방 식	영구 자석
극 수	8 극	취 부 방 법	FLANGE
진 동	24.5 m/s ² 이하	동 작 습 도	85%(결로없을 것)

항 목 \ CSME 모터		A3B	A5B	01B	02B	04B	08B
		A3	A5	01	02	04	10
적용 DRIVE	CSD3-__BX1	A3	A5	01	02	04	10
정격 전압	V	220					
정격 출력	W	30	50	100	200	400	750
정격 TORQUE	N·m	0.095	0.16	0.32	0.64	1.3	2.4
순시 최대 TORQUE	N·m	0.28	0.48	0.95	1.91	3.8	7.1
정격 회전 속도	RPM	3000					
최대 회전 속도	RPM	5000					4500
ROTOR INERTIA (BRAKE 부착 시)	Kg·m ² ·10 ⁻⁴	0.025 0.029	0.035 0.040	0.072 0.076	0.18 0.21	0.37 0.40	1.32 1.40
POWER RATE (BRAKE 부착 시)	kW/s	3.6 3.1	7.1 6.3	14.1 13.4	23.0 19.7	43.6 40.4	42.9 40.9
기계적 시정수 (BRAKE 부착 시)	ms	2.9 3.4	1.6 1.8	0.89 0.94	0.67 0.78	0.56 0.60	0.46 0.49
전기적 시정수	ms	0.61	0.67	0.88	3.4	3.5	7.4
정격 전류	A(rms)	1.0	1.0	1.0	1.6	2.5	4.3
순시 최대 전류	A(o-p)	4.3	4.3	4.3	6.9	10.5	18.3
축방향 유격	mm MAX	0.3 이하					
허용 THRUST 하중	N	29.4	58		98		147
허용 RADIAL 하중	N	49	68.6		245		392
질 량 (BRAKE 부착 시)	Kg	0.33 0.53	0.40 0.59	0.62 0.82	1.1 1.5	1.7 2.1	3.3 4.0
회전 방향		U → V → W : CCW					
색상		백색					
Oil Seal		옵션사양					

2. 브레이크 사양

항 목		CSME 모터명		
		A3, A5, 01B	02B, 04B	08B
정마찰 토크	N·m	0.29	1.27	2.45
회전자 inertia	$\text{kg} \cdot \text{m}^2 \times 10^{-4}$	0.003	0.03	0.09
브레이크 흡인 시간	Ms	25 이하	50 이하	60 이하
브레이크 해제 시간	ms	20 이하	15 이하	
해제 전압	VDC	1 이상		
정격 전압	VDC	24 ± 2.4		
정격 전류	A	0.26	0.36	0.43
허용 BRAKE 에너지 : 1 회	J	39.2	137	196
전체 허용 BRAKE 에너지	J	4.9×10^3	44.1×10^3	147×10^3

3. 속도-토크 곡선

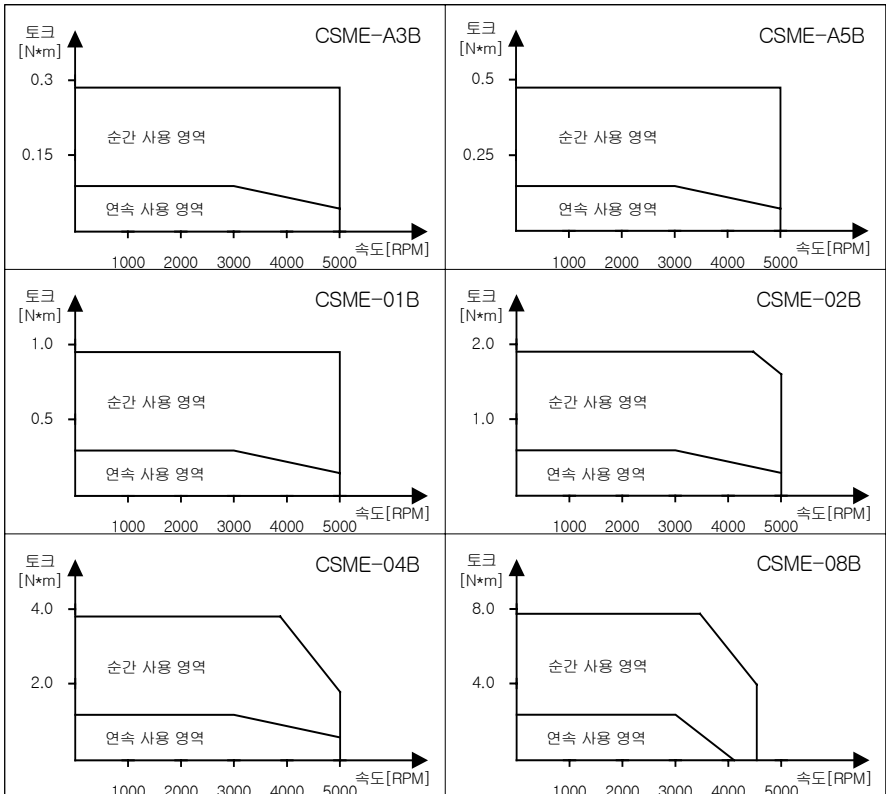

A.3.4 CSMW 모터(17bit 인코더 부착형)

1. 기본 사양

항 목	사 양	항 목	사 양
결 선 방 식	Y 결선	시 간 정 격	연속사용
동 작 온 도 범 위	0 ~ +40℃	절 연 등 급	B 중
보 존 온 도 범 위	-20 ~ +80℃	절 연 내 압 브레이크 부착 시	1500VAC 60sec 1200VAC 1sec
절 연 저 항	500VDC 20 MΩ	여 자 방 식	영구 자석
극 수	8 극	취 부 방 법	FLANGE
진 동	24.5 m/s ² 이하	동 작 습 도	85%(결로없을 것)

CSMW 모터		01B	02B	04B
적용 DRIVE	CSD3-__BX1	01	02	04
정격 전압	V	220		
정격 출력	W	100	200	400
정격 TORQUE	N·m	0.32	0.64	1.3
순시 최대 TORQUE	N·m	0.95	1.91	3.82
정격 회전 속도	RPM	3000		
최대 회전 속도	RPM	5000		
ROTOR INERTIA (BRAKE 부착 시)	Kg·m ² ·10 ⁻⁴	0.1 0.13	0.35 0.43	0.65 0.73
POWER RATE (BRAKE 부착 시)	kW/s	10.2 7.9	11.5 9.4	25.1 22.4
기계적 시정수 (BRAKE 부착 시)	ms	1.05 1.37	0.81 0.99	0.60 0.67
전기적 시정수	ms	2.9	5.6	6.6
정격 전류	A(rms)	1.0	1.6	2.5
순시 최대 전류	A(o-p)	4.3	6.8	10.5
축방향 유격	mm MAX	0.3 이하		
허용 THRUST 하중	N	58	98	
허용 RADIAL 하중	N	68.6	245	
질 량 (BRAKE 부착 시)	Kg	0.75 1.0	1.4 2.1	1.9 2.6
회전 방향		U →V →W : CCW		
색상		백색		
Oil Seal		옵션사양		

2. 브레이크 사양

항 목		CSMW 모터명	01B	02B, 04B
		정마찰 토크	N·m	0.29
회전자 inertia	$\text{kg} \cdot \text{m}^2 \times 10^{-4}$	0.03	0.09	
브레이크 흡인 시간	Ms	50 이하	60 이하	
브레이크 해제 시간	ms	15 이하		
해제 전압	VDC	1 이상		
정격 전압	VDC	24 ± 2.4		
정격 전류	A	0.29	0.41	
허용 BRAKE 에너지 : 1 회	J	137	196	
전체 허용 BRAKE 에너지	J	44.1×10^3	147×10^3	

3. 속도-토크 곡선

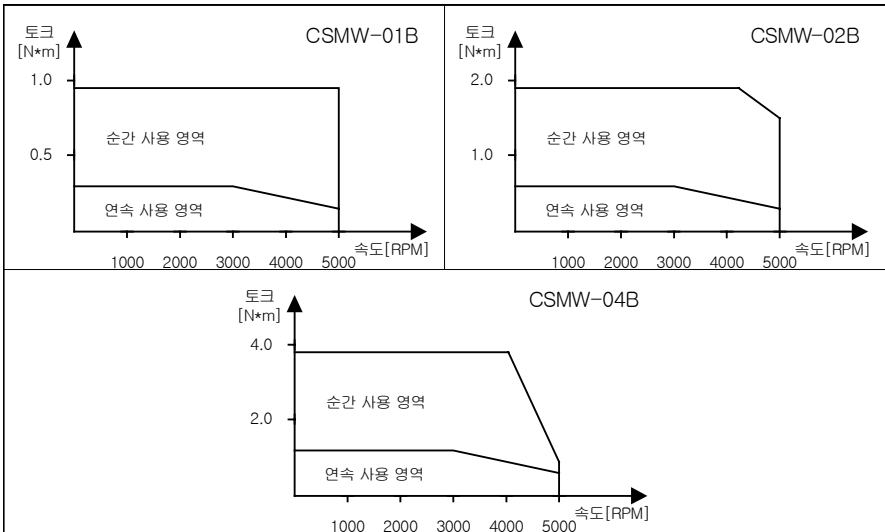

A.3.5 CSMQ 모터

1. 기본 사양

항 목	사 양	항 목	사 양
결 선 방 식	Y 결선	시 간 정 격	연속사용
동 작 온 도 범 위	0 ~ +40℃	절 연 등 급	B 종
보 존 온 도 범 위	-20 ~ +80℃	절 연 내 압	1500VAC 60sec 1800VAC 1sec
절 연 저 항	500VDC 20 MΩ	여 자 방 식	영구 자석
극 수	8 극	취 부 방 법	FLANGE
진 동	49 m/s ²	동 작 습 도	85%(결로없을 것)

CSMQ 모터		01B	02B	04B	08B	15B
적용 DRIVE	CSD3-__BX1	01	02	04	10	15
정격 전압	V	220				
정격 출력	kW	0.1	0.2	0.4	0.75	1.5
정격 TORQUE	Kgf·cm N·m	3.24	6.5	13	24.3	48.7
		0.318	0.637	1.274	2.4	4.77
순시 최대 TORQUE	Kgf·cm N·m	9.7	19.5	39	78	126
		0.95	1.911	3.822	7.64	12.3
정격 회전 속도	RPM	3000				
최대 회전 속도	RPM	5000			4500	
ROTOR INERTIA	gf·cm·s ² Kg·m ² ·10 ⁻⁴	0.09	0.35	0.65	1.43	2.87
		0.09	0.34	0.64	1.40	2.81
ROTOR INERTIA (BRAKE 부착 시)	gf·cm·s ² Kg·m ² ·10 ⁻⁴	0.12	0.43	0.73	1.74	3.18
		0.12	0.42	0.72	1.71	3.12
POWER RATE	kW/s	11.4	11.8	25.5	40.5	81.0
기계적 시정수	ms	0.95	0.79	0.59	0.64	0.55
전기적 시정수	ms	2.9	5.6	6.6	11.6	15.3
정격 전류	A(rms)	1.0	1.6	2.5	4.3	9.4
순시 최대 전류	A(rms)	3.04	4.80	7.42	13.37	30.69
축방향 유격	mm MAX	0.3				
허용 THRUST 하중	Kgf MAX	6	10		15	
허용 RADIAL 하중	Kgf MAX	7	25		40	
질 량	Kg	0.65	1.3	1.8	3.4	4.8
회전 방향		U →V →W : CCW				
색상		검정				
Oil Seal		옵션사양				

2. 브레이크 사양

항 목		CSMQ 모터명			
		01B	02B 04B	08B	15B
정마찰 토크	N·m Kgf·cm	0.29 이상 3	1.27 이상 13	2.45 이상 25	4.9 이상 50
회전자 inertia	$\text{kg} \cdot \text{m}^2 \times 10^{-4}$ $\text{gf} \cdot \text{cm} \cdot \text{s}^2$	0.03 0.03	0.09 0.09	0.33 0.33	
브레이크 흡인 시간	Ms	50 이하	60 이하		
브레이크 해제 시간	ms	15 이하		20 이하	
해제 전압	VDC	1 이상			
정격 전압	VDC	24 ± 2.4			
정격 전류	A	0.29	0.41	0.86	
허용 BRAKE 에너지 : 1 회	J Kgf·m	137 14	196 20	392 40	
전체 허용 BRAKE 에너지	J Kgf·m	44.1×10^3 4500	147×10^3 15000	490×10^3 50000	

3. 속도-토크 곡선

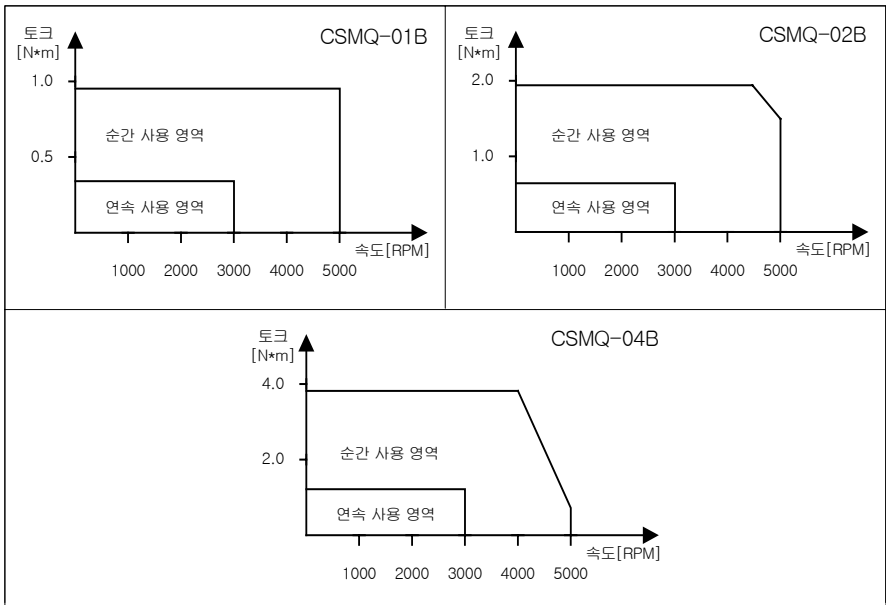

A.3.6 CSMZ 모터

1. 기본 사양

항목	사양	항목	사양
결선 방식	Y 결선	시간 정격	연속사용
동작 온도 범위	0 ~ +40℃	절연 등급	B 종
보존 온도 범위	-20 ~ +80℃	절연 내압	1500VAC 60sec 1800VAC 1sec
절연 저항	500VDC 20 MΩ	여자 방식	영구 자석
극 수	8 극	취부 방법	FLANGE
진동	49 m/s²	동작 습도	85%이하(결로없을 것)

항 목 \ CSMZ 모터		A3D	A5D	01B	02B	04B	08B
		A3	A5	01	02	04	10
적용 DRIVE	CSD3-__BX1	A3	A5	01	02	04	10
정격 전압	V	110/220		220			
정격 출력	W	30	50	100	200	400	750
정격 TORQUE	Kgf·cm N·m	0.97 0.095	1.62 0.159	3.24 0.318	6.5 0.637	13 1.274	24.3 2.38
순시 최대 TORQUE	Kgf·cm N·m	2.9 0.284	4.9 0.48	9.7 0.95	19.5 1.911	39 3.822	73 7.154
정격 회전 속도	RPM	3000					
최대 회전 속도	RPM	5000					4500
ROTOR INERTIA	gf·cm·s ² Kg·m ² ·10 ⁻⁴	0.016 0.016	0.026 0.025	0.063 0.062	0.17 0.17	0.37 0.36	1.34 1.31
ROTOR INERTIA (BRAKE 부착 시)	gf·cm·s ² Kg·m ² ·10 ⁻⁴	0.020 0.020	0.031 0.030	0.067 0.066	0.20 0.20	0.40 0.39	1.42 1.39
POWER RATE	kW/s	5.8	9.9	16.3	24.4	44.8	43.2
기계적 시정수	ms	1.8	1.2	0.77	0.63	0.54	0.45
전기적 시정수	ms	0.6	0.67	0.88	3.4	3.5	7.4
정격 전류	A(rms)	1.0	1.0	1.0	1.6	2.5	4.3
순시 최대 전류	A(rms)	3.04	3.04	3.04	4.87	7.42	12.93
축방향 유격	mm MAX	0.3					
허용 THRUST 하중	Kgf MAX	3	6		10		15
허용 RADIAL 하중	Kgf MAX	5	7		25		40
중량	Kg	0.27	0.34	0.56	1.0	1.6	3.2
회전 방향		U →V →W : CCW					
색상		검정					
Oil Seal		옵션사양					

2. 브레이크 사양

항 목		CSMZ 모터					
		A3D	A5D	01B	02B	04B	08B
정마찰 토크	N·m Kgf·cm	0.29 이상 3		1.27 이상 13		2.45 이상 25	
회전자 inertia	$\text{kg} \cdot \text{m}^2 \times 10^{-4}$	0.003		0.03		0.09	
브레이크 흡인 시간	ms	25 이하		50 이하		60 이하	
브레이크 해제 시간	ms	20 이하		15 이하		15 이하	
해제 전압	VDC	1 이상					
정격 전압	VDC	24 ± 2.4					
정격 전류	A	0.26		0.36		0.43	
허용 BRAKE 에너지 : 1 회	J Kgf·m	39.2 4		137 14		196 20	
전체 허용 BRAKE 에너지	J Kgf·m	4.9×10^3 500		44.1×10^3 4500		147×10^3 15000	

3. 속도-토크 곡선

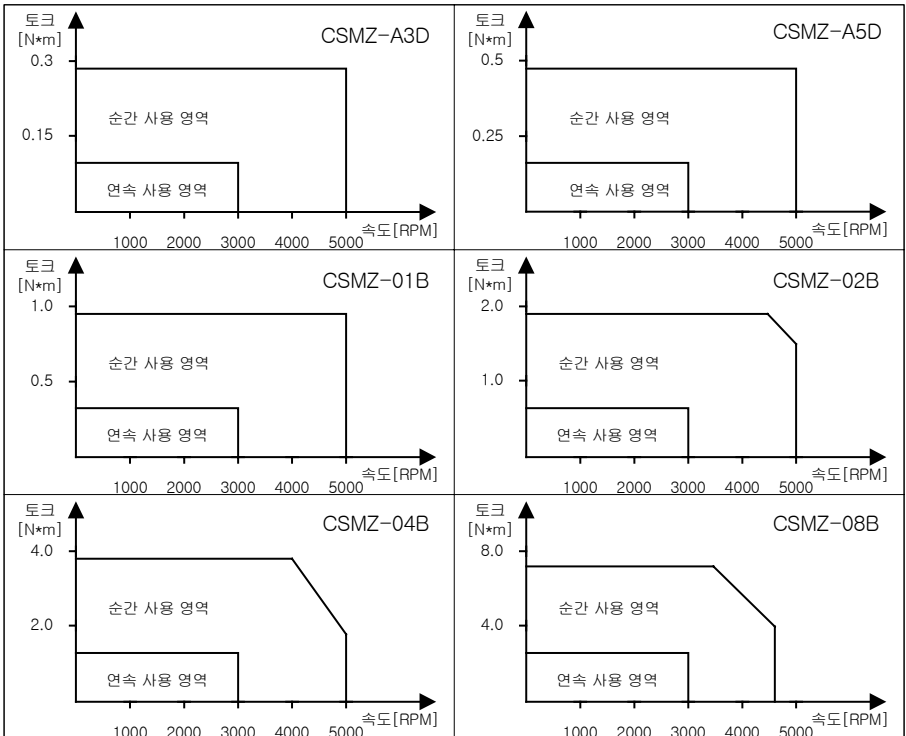

A.3.7 CSMD 모터

1. 기본 사양

항 목	사 양	항 목	사 양
결 선 방 식	Y 결선	시 간 정 격	연속사용
동 작 온 도 범 위	0 ~ +40℃	절 연 등 급	F 중
보 존 온 도 범 위	-20 ~ +80℃	절 연 내 압 브레이크 부착 시	1500VAC 60sec
절 연 저 항	500VDC 20 MΩ		1200VAC 60sec
극 수	8 극	여 자 방 식	영구 자석
진 동	49 m/s ² (정지 시 24.5)	취 부 방 법	FLANGE
충 격	98 m/s ² 3 회	동 작 습 도	85%이하(결로없을 것)

항 목 \ CSMD 모터		08B	10B	15B	20B	25B	30B	35B	40B	45B	50B
		적용 DRIVE	CSD3-__BX1	10	10	15					
정격 전압	V	220									
정격 출력	kW	0.75	1.0	1.5	2.0	2.5	3.0	3.5	4.0	4.5	5.0
정격 TORQUE	Kg·cm N·m	36.4	49	73	97.4	121	146	169	192	219	243
		3.57	4.8	7.15	9.54	11.86	14.3	16.6	18.8	21.4	23.8
순시 최대 TORQUE	Kg·cm N·m	109	147	219	292	363	438	510	576	657	729
		10.7	14.4	21.5	28.5	35.6	42.9	50.0	56.4	64.3	71.4
정격 회전 속도	RPM	2000									
최대 회전 속도	RPM	3000									
ROTOR INERTIA	gf·cm·s ² Kg·m ² ·10 ⁻⁴	2.88	6.30	11.4	15.5	19.6	22.8	36.6	43.4	51.6	61.9
		2.82	6.17	11.2	15.2	19.2	22.3	35.9	42.5	50.6	60.7
ROTOR INERTIA (BRAKE 부착 시)	gf·cm·s ² Kg·m ² ·10 ⁻⁴	3.19	6.93	12.6	17.0	21.5	25.1	41.0	47.8	56.7	68.1
		3.13	6.17	12.3	16.7	21.1	24.6	40.2	46.8	55.6	66.7
POWER RATE	kW/s	45.1	37.3	45.8	60.0	73.2	91.6	76	83.2	91.1	93.5
기계적 시정수	ms	0.5	0.7	0.81	0.75	0.72		1.0		0.9	
전기적 시정수	ms	15.7	18	19	21		20	24		30	32
정격 전류	A(rms)	5.0	5.6	9.4	12.3	14	17.8	18.7	23.4	26.2	28
순시 최대 전류	A(rms)	15	16.8	28.2	36.9	42	53.4	56.1	70.2	78.6	84
축방향 유격	mm MAX	0.3									
운전 시 허용 THRUST 하중	Kgf MAX	15	20			35					
운전 시 허용 RADIAL 하중	Kgf MAX	40	50			80					
결합 시 허용 THRUST 하중	Kgf MAX	40	60				80				
결합 시 허용 RADIAL 하중	Kgf MAX	70	100				170				

항 목		CSMD 모터									
		08B	10B	15B	20B	25B	30B	35B	40B	45B	50B
중 량 (BRAKE 부착 시)	Kg	4.8	6.8	8.5	10.6	12.8	14.6	16.2	18.8	21.5	25
		6.5	8.7	10.1	12.5	14.7	16.5	18.7	21.3	25	28.5
회전 방향		U →V →W									
색상		검정									
Oil Seal		기본탑재									

2. 브레이크 사양

항 목		CSMD 모터						
		08B	10B	15B 20B	25B 30B	35B 40B	45B 50B	
정마찰 토크	N·m	7.84 이상	4.9 이상	13.7 이상	16.1 이상	21.5 이상	24.5 이상	
	Kgf·cm	80	50	140	165	220	250	
회전자 inertia	$\text{kg} \cdot \text{m}^2 \times 10^{-4}$	0.33	1.35			4.25	9.0	
	$\text{Kgf} \cdot \text{cm} \cdot \text{s}^2$	0.34	1.38			4.34	9.18	
브레이크 흡인 시간	ms	50 이하	80 이하	100 이하	110 이하	90 이하	80 이하	
브레이크 해제 시간	ms	15 이하	70 이하	50 이하		35 이하	25 이하	
해제 전압	VDC	2 이상						
정격 전압	VDC	24 ± 2.4						
정격 전류	A	0.81±10%	0.59±10%	0.79±10%	0.90±10%	1.1±10%	1.3±10%	
허용 BRAKE 에너지:1 회	J	392	588	1176	1470	1078	1372	
	Kgf·m	40	60	120	150	110	140	
전체 허용 BRAKE 에너지	J	4.9×10^5	7.8×10^5	1.5×10^6	2×10^6	2.4×10^6	2.9×10^6	
	Kgf·m	5×10^4	8×10^4	1.5×10^5	2.2×10^5	2.5×10^5	3×10^5	

3. 속도-토크 곡선

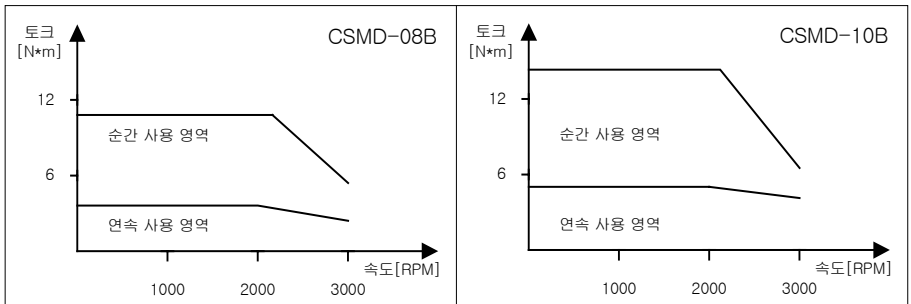

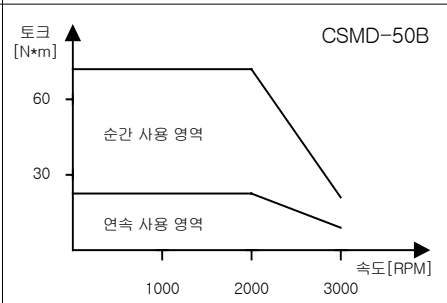
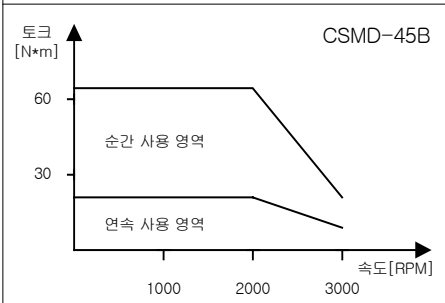
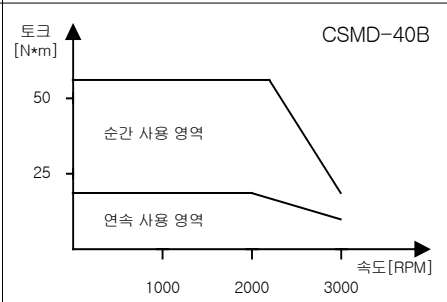
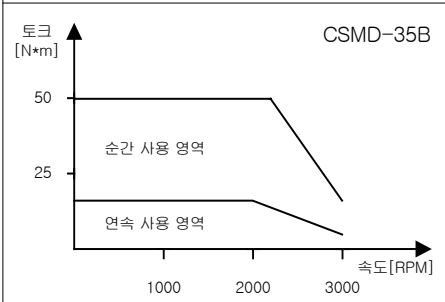
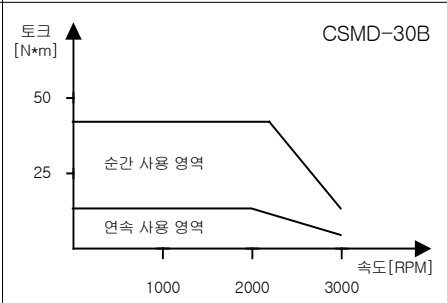
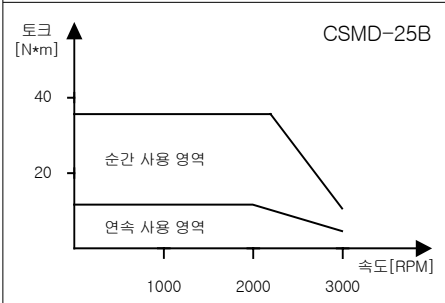
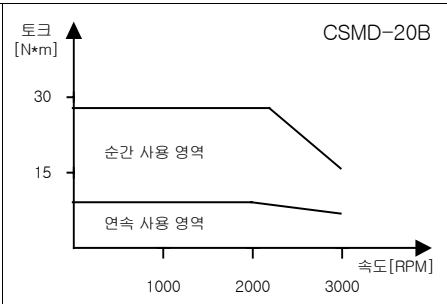
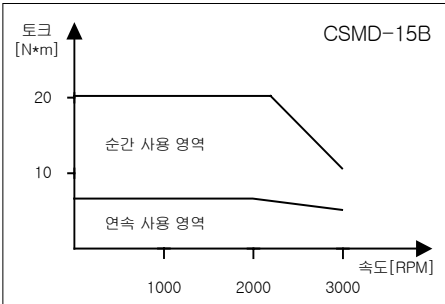

A.3.8 CSMF 모터

1. 기본 사양

항 목	사 양	항 목	사 양
결 선 방 식	Y 결선	시 격	연속사용
동	0 ~ +40℃	절 연 등 급	F 종
보 존 온 도 범 위	-20 ~ +80℃	절 연 내 압 브	1500VAC 60sec 1200VAC 60sec
절 연 저 항	500VDC 20 MΩ		
극 수	8 극	여 자 방 식	영구 자석
진 동	49 m/s ² (정지 시 24.5)	취 부 방 법	FLANGE
총 격	98 m/s ² 3 회	동 작 습 도	85%이하(결로없을 것)

CSMF 모터명		04B	08B	15B	25B	35B	45B
항 목	CSM3-__BX1	04	10	15			
적용 DRIVE	CSD3-__BX1	04	10	15			
	V	220					
	KW	0.4	0.75	1.5	2.5	3.5	4.5
정격 TORQUE	Kg N·m	19.5	36.4	73	121	169	219
		1.91	3.57	7.15	11.86	16.56	21.46
순시 최대	K N·m	58.5	109	219	310	450	560
		5.3	10.68	21.46	30.38	44.1	54.88
정격 도	RPM	2000					
최대 회전 속도	RPM	3000					
ROTOR INERTIA	gf Kg·m ² ·10 ⁻⁴	2.50	10.3	20.5	42.1	52.7	73.8
		2.45	10.1	20.1	41.3	51.6	72.3
ROTOR INERTIA ()	gf·cm·s ² Kg·m ² ·10 ⁻⁴	2.8	11.1	21.9	46.2	56.8	80.1
		2.7	10.9	21.5	45.3	55.7	78.5
POWER RATE	kW/s	14.9	12.6	25.5	34	53.1	63.7
기	ms	1.2	1.9	1.4	1.3	1.06	0.88
전기적 시정수	ms	14	21	25	35	41	
정격 전류	A()	2.8	5.0	9.5	13.4	20	23.5
순	A(rms)	8.4	15	28.5	40.2	60	70.5
축방향 유격	mm MAX	0.3					
운전 시 허용 중	KgF MAX	15	20		30		
		40	50		80		
허용 중	KgF MAX	60			70		
허용 RADIAL 하중	KgF MAX	100			190		

항 목		CSMF 모터명					
		04B	08B	15B	25B	35B	45B
중 량 (BRAKE 부착 시)	Kg	4.7	8.6	11	14.8	15.5	19.9
		6.7	10.6	14	17.5	19.2	24.3
회전 방향		U →V →W					
		검정					
Oil Seal		기본탑재					

2. 브레이크 사양

항 목		CSMF 모터			
		04B	08B 15B	25B 35B	45B
정마찰 토크	N·m	4.9 이상	7.8 이상	21.6 이상	31.4 이상
	Kgf·cm	50	80	220	320
회전자 inertia	$kg \cdot m^2 \times 10^{-4}$	1.35	4.7	8.75	8.75
	$gf \cdot cm \cdot s^2$	1.38	9.2	8.9	8.9
브레이크	ms	80 이하		150 이하	
브레이크	ms	70 이하	35 이하	100 이하	
	VDC	2 이상			
	VDC	24 ± 2.4			
	A	0.59±10%	0.83±10%	0.75±10%	
에너지:1회	J	588	1372	1470	
	Kg	60	140	150	
전체 허용 BRAKE 에너지	J	7.8×10^5	2.9×10^6	1.5×10^6	2.2×10^6
	Kgf·m	8×10^4	3×10^5	1.5×10^5	2.2×10^5

3. 속도-토크 곡선

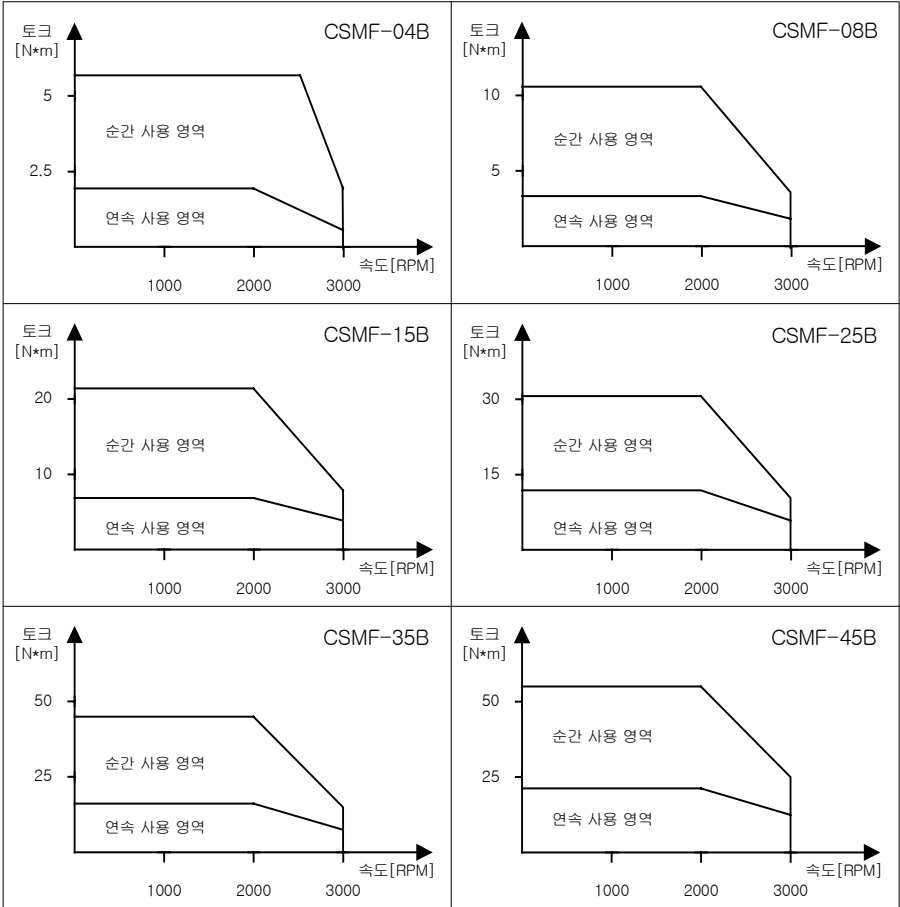

A.3.9 CSMH 모터

1. 기본 사양

항목	사양	항목	사양
결선 방식	Y 결선	시	연속사용
동 위	0 ~ +40℃	절연 등급	F 중
보존 온도 범위	-20 ~ +80℃	절연 내압 브레이크 부착 시	1500VAC 60sec
절연 저항	500VDC 20 MΩ		1200VAC 60sec
	8극	여자 방식	영구 자석
진동	49 m/s ² (정지 시 24.5)	취부 방법	FLANGE
충격	98 m/s ² 3회	동작 습도	85%이하(결로없을 것)

CSMH 모터		05B	10B	15B	20B	30B	40B	50B
적용 DRIVE	CSD3-__BX1	10	10	15				
	V	220						
	KW	0.5	1	1.5	20	30	40	50
정격 TORQUE	Kg N·m	24.3	49	73	97.4	146	192	243
		2.38	4.8	7.15	9.54	14.31	18.8	23.8
순시 최대 TORQUE	K N·m	61.0	147	219	292	438	576	729
		6.0	14.4	21.5	28.5	42.9	56.4	71.4
정격 도	RPM	2000						
최대 회전 속도	RPM	3000						
ROTOR INERTIA	gf Kg·m ² ·10 ⁻⁴	14.3	26.5	43.8	63.3	96.0	122.4	173.5
		14.0	26.0	42.9	62.0	94.1	120.0	170.0
ROTOR INERTIA (BRAKE 부착 시)	Kg·m ² ·10 ⁻⁴	15.5	27.8	45.0	69.3	102	128.6	179.6
		15.2	27.2	44.1	67.9	100.0	126.0	176.0
POWER RATE	kW/s	4.0	8.9	11.9	14.7	21.8	29.5	33.4
기	ms	4	2.9	3.1	2.1	2.5	2.2	2.3
전기적 시정수	ms	15	18	19	26		30	31
정격 전류	A(3.2	5.6	9.4	12.3	17.8	23.4	28.0
순	A(rms)	8.1	16.8	28.0	36.7	53.6	70.2	84.0
축방향 유격	mm MAX	0.3						
운전 시 허용 THRUST 하중		20			35			
허용 RADIAL 하중	Kgf MAX	50			80			
허용 THRUST 하중	Kgf MAX	60			80			
허용 RADIAL 하중	Kgf MAX	100			170			

항 목 중 량 (BRAKE 부착 시)		CSMH 모터						
		05B	10B	15B	20B	30B	40B	50B
Kg		5.3 6.9	8.9 9.5	10.0 11.6	16.0 19.5	18.2 21.7	22.0 25.5	26.7 30.2
회전 방향		U →V →W						
		검정						
Oil Seal		기본탑재						

2. 브레이크 사양

항 목		CSMH 모터		
		05B 10B	15B	20B, 30B 40B, 50B
정마찰 토크	N·m Kgf·cm	4.9 이상 50	13.7 이상 140	24.5 이상 250
회전자 inertia	kg·m ² ×10 ⁻⁴ gf·cm·s ²	1.35 1.38		9.0 9.18
브레이크	ms	80 이하	100 이하	80 이하
브레이크	ms	70 이하	50 이하	25 이하
	VDC	2 이상		
	VDC	24 ± 2.4		
	A	0.59±10%	0.79±10%	1.3±10%
허용 BRAKE 에너지:1 회	J Kg	588 60	1176 120	1372 140
전체 허용 BRAKE 에너지	J Kgf·m	7.8×10 ⁵ 8×10 ⁴	1.5×10 ⁶ 3×10 ⁵	2.9×10 ⁶ 1.5×10 ⁵

3. 속도-토크 곡선

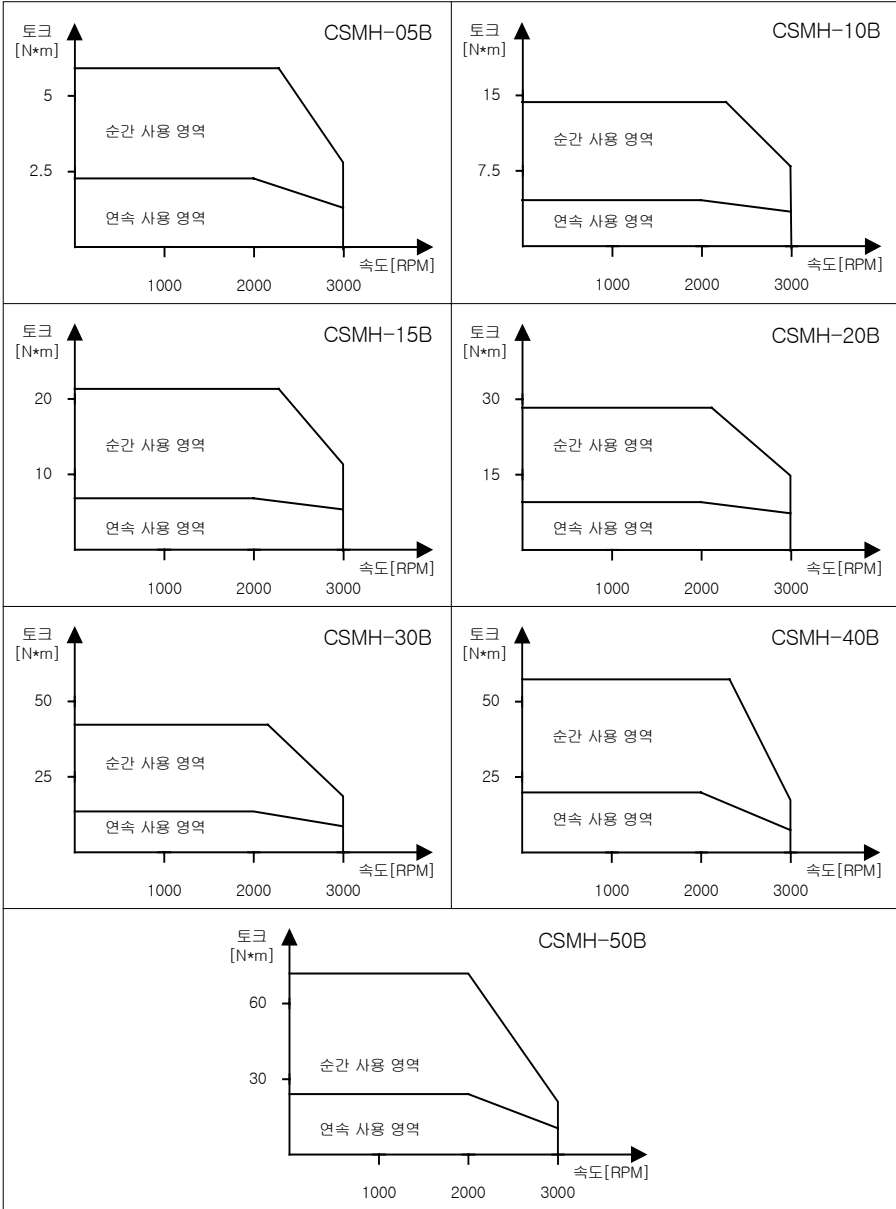

A.3.10 CSMS 모터

1. 기본 사양

항 목	사 양	항 목	사 양
결 선 방 식	Y 결선	시 간 정 격	연속사용
동 작 온 도 범 위	0 ~ +40℃	절 연 등 급	F 중
보 존 온 도 범 위	-20 ~ +80℃	절 연 내 압 브레이크 부착 시	1500VAC 60sec
절 연 저 항	500VDC 20 MΩ		1200VAC 60sec
극 수	8 극	여 자 방 식	영구 자석
진 동	49 m/s²(정지 시 24.5)		FLANGE
총 격	98 m/s² 3 회	동 작 습 도	85%이하(결로없을 것)

항 목 \ CSMS 모		10B	15B	20B	25B	30B	35B	40B	45B	50B
		CSD3-__BX1								
적용 DRIVE	CSD3-__BX1	10	15							
정격 전압	V	220								
정격 출력	kW	1.0	1.5	2.0	2.5	3.0	3.5	4.0	4.5	5.0
정격 TORQUE	Kg·m N·m	32.4 3.18	48.7 4.77	64.9 6.36	81 7.94	97.3 9.54	113 11.07	129 12.64	146 14.31	162 15.88
순시 최대	Kgf·cm N·m	97 9.51	146 14.31	195 19.11	243 23.81	292 28.62	339 33.22	387 37.93	438 42.92	486 47.63
정격 회전 속도	RPM	3000								
최대 도	RPM	5000						4500		
ROTOR INERTIA	gf Kg·m ² ·10 ⁻⁴	1.72	2.64	3.53	4.40	6.91	8.06	13.0	15.6	18.2
		1.69	2.59	3.46	4.31	6.77	7.90	12.7	15.3	17.8
ROTOR INERTIA ()	gf·cm·s ² Kg·m ¹⁰	1.92	2.90	3.89	4.84	7.60	8.88	14.4	17.3	20.1
		1.88	2.84	3.81	4.74	7.45	8.69	14.1	17.0	19.7
POWER RATE	kW/s	60	88	117	146	134	155	125	134	140
	ms	0.78	0.54	0.53	0.52	0.46	0.45	0.51	0.45	0.46
전	ms	6.7	10	10.8	11	17	20			
정격 전류	A(7.2	9.4	13	15.9	18.6	21.6	24.7	28	28.5
순시 최대 전류	A(21.6	28.2	39	47.7	55.8	64.8	74.1	84	85.5
축	mm MAX	0.3								
운전 시 허용 THRUST 하중		15	20			35				
운전 시 허용 중	Kgf MAX	40	50			80				
허용 중	Kgf MAX	40	60							
허용 RADIAL 하중	Kgf MAX	70	100							

중량 (BRAKE 부착 시)		CSMS 모터								
		10B	15B	20B	25B	30B	35B	40B	45B	50B
Kg		4.5 5.1	5.1 6.5	6.5 7.9	7.5 8.9	9.3 11.0	10.9 12.6	12.9 14.8	15.1 17.0	17.3 19.2
회전 방향		U →V →W								
색상		검정								
Oil Seal		기본탑재								

2. 브레이크 사양

항 목		CSMS 모터			
		10B	15B 25B	B 35B	40B 50B
정마찰 토크	N·m ·cm	4.9 이상 50	7.8 이상 80	11.8 이상 120	16.1 이상 165
회전자 inertia	$kg \cdot m^2 \times 10^{-4}$ gf·cm·s	0.25 0.26	0.33 0.33	1.35 1.38	
브레이크	ms	50 이하		80 이하	110 이하
브레이크	ms	*115 이하			**50 이하
해제 전압	VDC	2 이상			
	VDC	24 ± 2.4			
	A	0.74±10%	0.81±10%		0.90±10%
허용 BRAKE	J	392			1470
	K	40			150
B	J	2.0×10 ⁵	4.9×10 ⁵	4.9×10 ⁶	2×10 ⁶
	Kg	2×10 ⁴	5×10 ⁴	5×10 ⁵	2.2×10 ⁵

3. 속도-토크 곡선

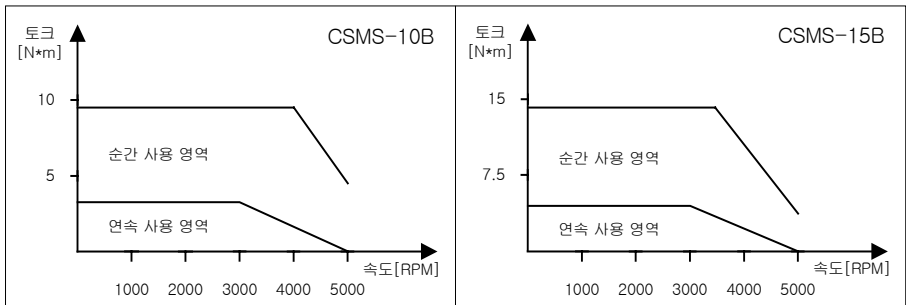

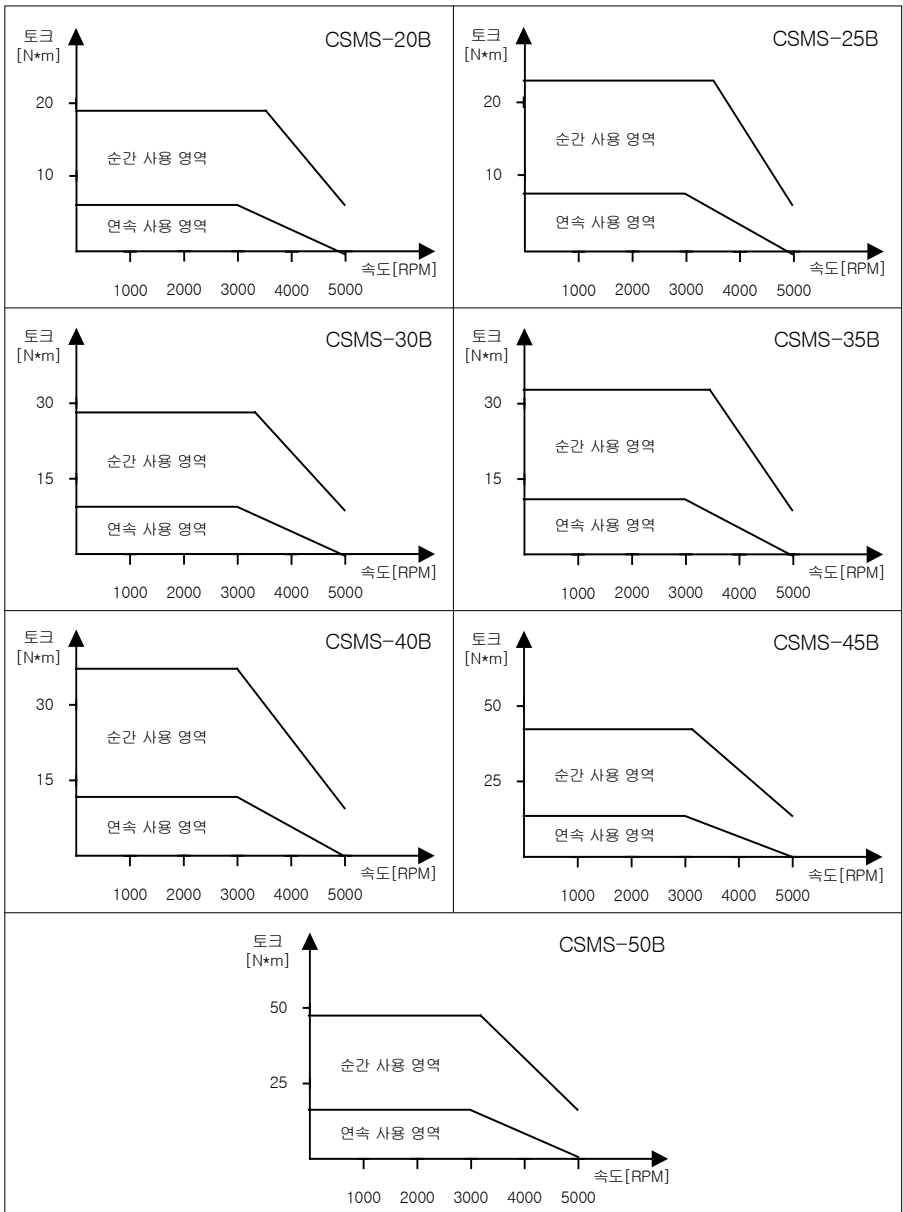

A.3.11 CSMK 모터

1. 기본 사양

항 목	사 양	항 목	사 양
결 선 방 식	Y 결선	시 간 정 격	연속사용
동 작 온 도 범 위	0 ~ +40℃	절 연 등 급	F 중
보 존 온 도 범 위	-20 ~ +80℃	절 연 내 압 브레이크 부착 시	1500VAC 60sec
절 연 저 항	500VDC 20 MΩ		1200VAC 60sec
극 수	8극	여 자 방 식	영구 자석
진 동	49 m/s² (정지 시 24.5)		FLANGE
총 격	98 m/s² 3 회	동 작 습 도	85%이하(결로없을 것)

항 목		CSMK 모							
		03B	06B	09B	12B	20B	30B	45B	60B
적용 DRIVE	CSD3-__BX1	04	10	10	15				
정격 전압	V	220							
정격 출력	kW	0.3	0.6	0.9	1.2	2.0	3.0	4.5	6.0
정격 TORQUE	Kg·m N·m	28.9	58.1	87.9	117.2	195	289.5	437.4	583.2
		2.84	5.7	8.62	11.5	19.1	28.4	42.9	57.2
순시 최대	Kgf·cm N·m	64.3	146.8	196.8	285.5	448.6	649.5	1091	1320
		6.3	14.4	19.3	28.0	44.0	63.7	107	129
정격 회전 속도	RPM	1000							
최대 도	RPM	2000							
ROTOR INERTIA BRAKE 부착 시	Kg·m ²	3.9	6.17	11.2	30.4	35.5	55.7	80.9	99
		5.1	7.45	12.3	36.2	41.4	61.7	89.2	108
POWER RATE	kW/s	20.7	52.7	66.3	43.3	103	145	228	331
		15.8	43.6	60.4	36.3	88.3	131	207	304
기계적 시정수 B	ms	1.4	0.81	0.88	1	0.97	0.74	0.70	0.9
		1.8	0.98	0.96	1.2	1.1	0.82	0.78	0.98
전기적 시정수	ms	14	17	20	26	25	30	31	33
정격 전류	A()	3	5.7	7.6	11.6	18.5	24	33	47
순시 최대 전류	A()	11	21	24	40	60	80	118	155
축	mm MAX	0.3							
중 량 (BRAKE 부착 시)		5.1	6.8	8.5	15.5	17.5	25	34	41
		6.7	8.4	10	19	21	28.5	39.5	46.5
색상		검정							

2. 브레이크 사양

CSMK 모터		03B	06B 09B	12B 20B	30B, 45B 60B
정마찰 토크	N·m Kgf·cm	4.9 이상 50	11.8 이상 120	24.5 이상 250	58.8 이상 600
회전자 inertia	$\text{kg} \cdot \text{m}^2 \times 10^{-4}$ gf	1.35 1.38		4.7 4.7	
브레이크	ms	80 이하			150 이하
브레이크	ms	70 이하	15 이하	25 이하	50 이하
	VDC	2 이상			
	VDC	24 ± 2.4			
정격 전류	A	0.59±10%	0.81±10%	1.3±10%	1.4±10%
에너지 : 1 회	K	60	40	140	
전체 허용 B	Kgf·m	8×10^4	5×10^4	3×10^5	3×10^4

3. 속도-토크 곡선

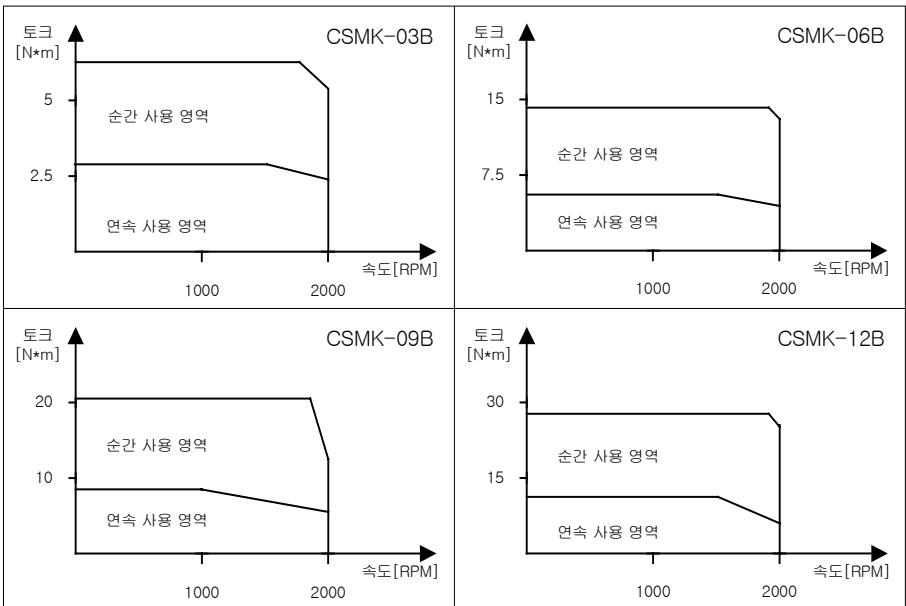

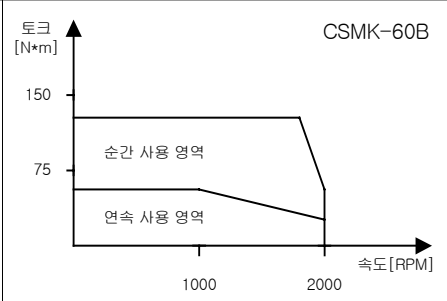
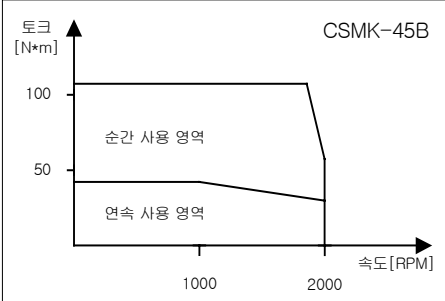
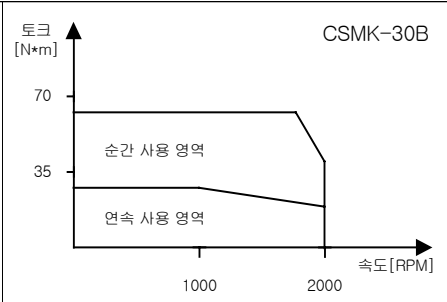
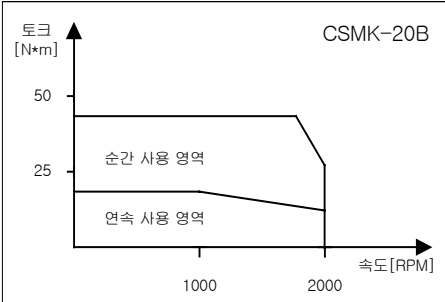

A.4

A.4	284
A.4.1 CSM	284
A.4.2 CSM	286
A.4.3 CSMT	(17bit)	289
A.4.4 CSMZ	291
A.4.5 CSME	(17bit)	292
A.4.6 CSMQ	293
A.4.7 CSMW	(17bit)	294
A.4.8 CSMD/F/H/K/S	295

A.4

A.4.1 CSM

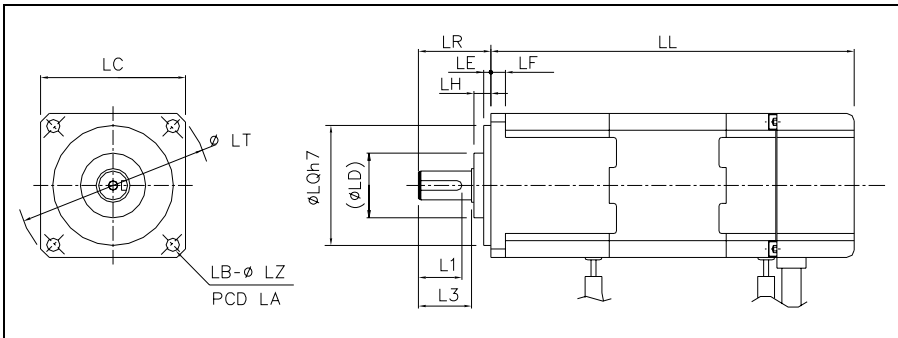

		A3B	A5B	01B	02B	04B	06B	08B	10B
LL	BRAKE 無	61.5	70.5	88.5	93	121	125	142	163
	BRAKE 有	92.5	101.5	119.5	122.5	150.5	156	173	194
LR		25			330		35		
LE		2.5			3		3		
LF		5			6		8		
LH		4.5			7		7		
LQ		30			50		70		
LD		20			27		34		
L1		17			18		23		
L3		20			22		27		
LC		40			60		80		
LT		55			80		105		
LB		2			4		4		
LZ		4.5			5.5		6.5		
LA		46			70		90		

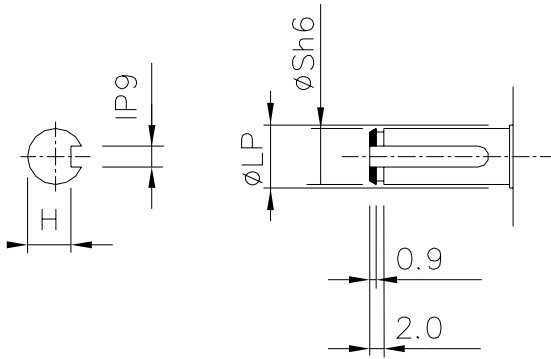

	A3B	A5B	01B	02B	04B	06B	08B	10B
LP	9		14		20			
S	8		12		16			
H	6.2		9.5		13			
I	3		4		5			

A.4.2 CSM

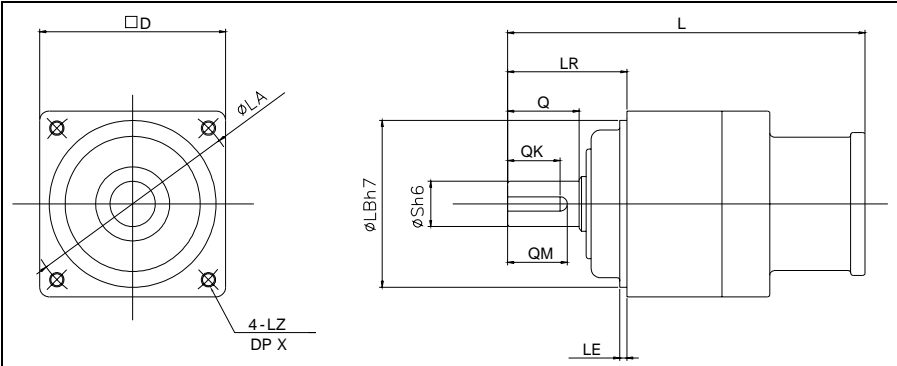

			L	LR	LB	LA	LE	LZ	D	X							
A5B	B	1/3	99.5	32	50	60	3	M5	52	12							
		1/5															
		1/9	110														
		1/15															
		1/25															
01B	B	1/3	99.5	32	50	60	3	M5	52	12							
		1/5															
		1/9	110														
		1/15															
	C	1/25	142								50	70	90	3	M6	78	20
02B	B	1/3	104.5	32	50	60	3	M5	52	12							
		1/5															
	C	1/9	150								50	70	90	3	M6	78	20
		1/15															
		1/25															
04B	B	1/3	104.5	32	50	60	3	M5	52	12							
	C	1/5	139.5														
		1/9	150														
		1/15															
		D	1/25								165	61	90	115	5	M8	96

06B	C	1/3	143.5	50	70	90	3	M6	78	20
		1/5								
	D	1/9	171	61	90	115	5	M8	96	20
		1/15								
08B	C	1/3	143.5	50	70	90	3	M6	78	20
		1/5								
	D	1/9	171	61	90	115	5	M8	96	20
		1/15								
	E	1/25	210	75	110	135	5	M10	125	20

			Q	QM	QK	S	W×U	T
A5B	B	1/3	20	18	16	12	4×2.5	4
		1/5						
		1/9						
		1/15						
		1/25						
01B	B	1/3	20	18	16	12	4×2.5	4
		1/5						
		1/9						
		1/15						
	C	1/25	30	26	22	19	6×3.5	6
02B	B	1/3	20	18	16	12	4×2.5	4
		1/5						
	C	1/9	30	26	22	19	6×3.5	6
		1/15						
		1/25						

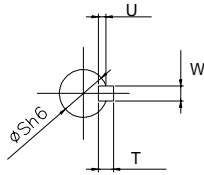

04B	B	1/3	20	18	16	12	4×2.5	4
	C	1/5	30	26	22	19	6×3.5	6
		1/9						
		1/15						
D	1/25	40	35	30	24	8×4	7	
06B	C	1/3	30	26	22	19	6×3.5	6
		1/5						
	D	1/9	40	35	30	24	8×4	7
		1/15						
08B	C	1/3	30	26	22	19	6×3.5	6
		1/5						
	D	1/9	40	35	30	24	8×4	7
		1/15						
	E	1/25	55	52	45	32	10×5	8

A.4.3 CSMT

(17bit)

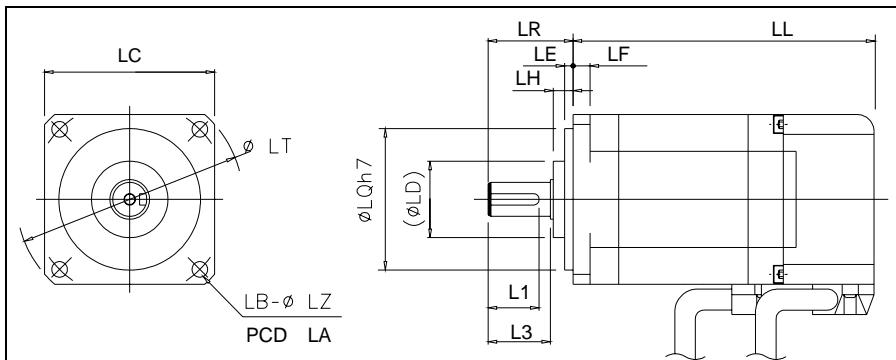

		A3B	A5B	01B	02B	04B	06B	08B	10B
LL	BRAKE 無	53.5	59.5	73.5	76.1	98.1	99.7	108.7	144.2
	BRAKE 有	89.1	95.1	109.1	110.7	132.7	136.3	145.3	167.2
LR		25			330		35		
LE		2.5			3		3		
LF		5			6		8		
LH		4.5			7		7		
LQ		30			50		70		
LD		20			27		34		
L1		17			18		23		
L3		20			22		27		
LC		40			60		80		
LT		55			80		105		
LB		2			4		4		
LZ		4.5			5.5		6.5		
LA		46			70		90		

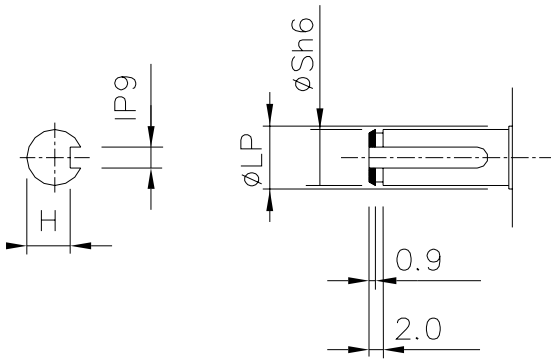

	A3B	A5B	01B	02B	04B	06B	08B	10B
LP	9			14	20			
S	8			12	16			
H	6.2			9.5	13			
I	3			4	5			

A.4.4 CSMZ

	LL				LR	S	LA	LB	LC	LE	LF	LZ
	BRAKE 有		BRAKE 無									
	Abs.	Inc.	Abs.	Inc.								
CSMZ - A3D	122	97	90	65	25	7	45	30	38	3	6	3.4
CSMZ - A5D	130	105	98	73	25	8	45	30	38	3	6	3.4
CSMZ - 01B	160	135	128	103	25	8	45	30	38	3	6	3.4
CSMZ - 02B	152	127	119	94	30	11	70	50	60	3	7	4.5
CSMZ - 04B	181.5	156.5	148.5	123.5	30	14	70	50	60	3	7	4.5
CSMZ - 08B	202.5	177.5	167.5	142.5	35	19	90	70	80	3	8	6

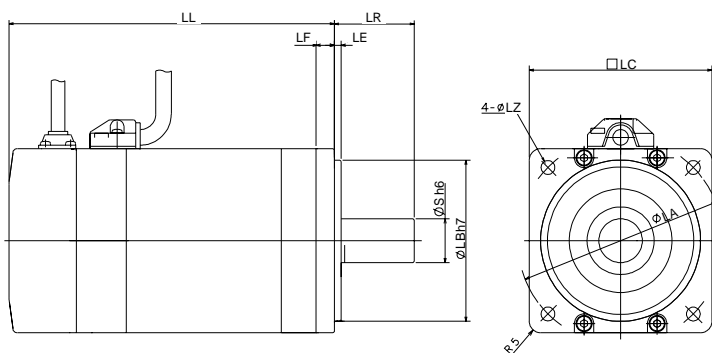

	L1	L2	H1	H2	H3
CSMZ - A3D	13	12	5.8	2	2
CSMZ - A5D	14	12.5	6.2	3	3
CSMZ - 01B	14	12.5	6.2	3	3
CSMZ - 02B	20	18	8.5	4	4
CSMZ - 04B	25	22.5	11	5	5
CSMZ - 08B	25	22	15.5	6	6

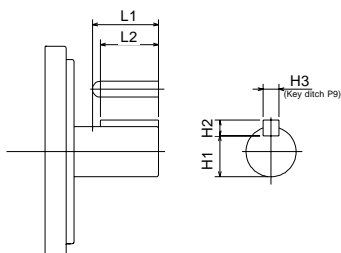

A.4.5 CSME (17bit)

	LL		LR	S	LA	LB	LC	LE	LF	LZ
	BRAKE 有	BRAKE 無								
CSME - A3D	113.5	81.5	25	7	45	30	38	3	6	3.4
CSME - A5D	121.5	89.5	25	8	45	30	38	3	6	3.4
CSME - 01B	151.5	119.5	25	8	45	30	38	3	6	3.4
CSME - 02B	142	109	30	11	70	50	60	3	7	4.5
CSME - 04B	171.5	138.5	30	14	70	50	60	3	7	4.5
CSME - 08B	192.5	157.5	35	19	90	70	80	3	8	6

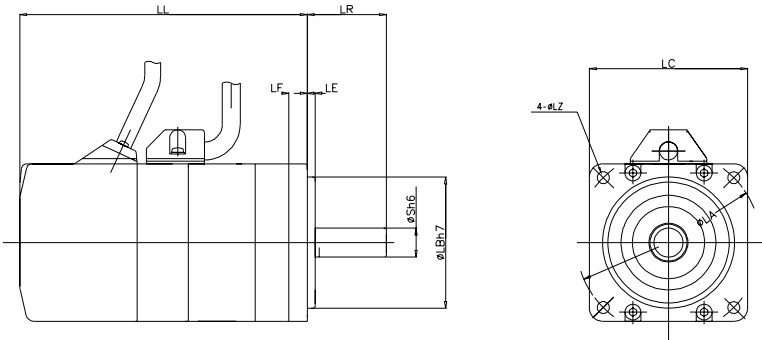

	L1	L2	H1	H2	H3
CSME - A3D	13	12	5.8	2	2
CSME - A5D	14	12.5	6.2	3	3
CSME - 01B	14	12.5	6.2	3	3
CSME - 02B	20	18	8.5	4	4
CSME - 04B	25	22.5	11	5	5
CSME - 08B	25	22	15.5	6	6

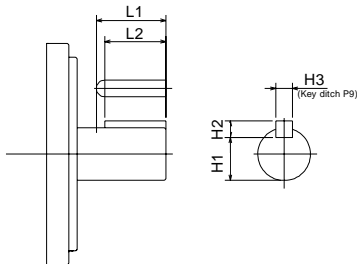

A.4.6 CSMQ

	LL		LR	S	LA	LB	LC	LE	LF	LZ
	BRAKE 有	BRAKE 無								
CSMQ-01B	84	60	25	8	70	50	60	3	7	4.5
CSMQ-02B	99.5	67	30	11	90	70	80	5	8	5.5
CSMQ-04B	114.5	82	30	14	90	70	80	5	8	5.5

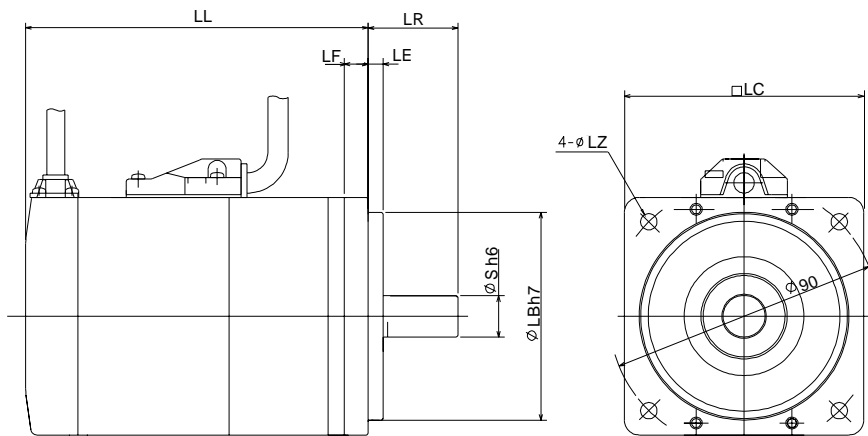

	L1	L2	H1	H2	H3
CSMQ-01B	14	12.5	6.2	3	3
CSMQ-02B	20	18	8.5	4.	4
CSMQ-04B	25	22.5	11	5	5

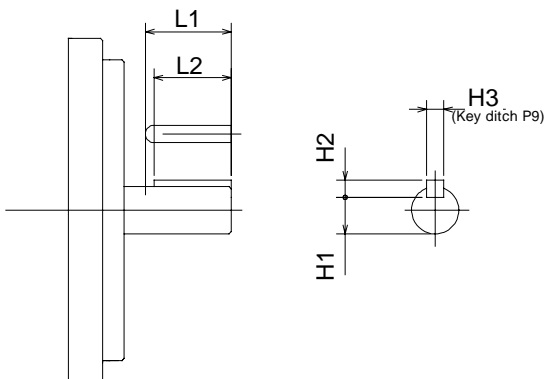

A.4.7 CSMW (17bit)

	LL		LR	S	LA	LB	LC	LE	LF	LZ
	BRAKE 有	BRAKE 無								
CSMW-01B	111	87	25	8	70	50	60	3	7	4.5
CSMW-02B	126.5	94	30	11	90	70	80	5	8	5.5
CSMW-04B	141.5	109	30	14	90	70	80	5	8	5.5

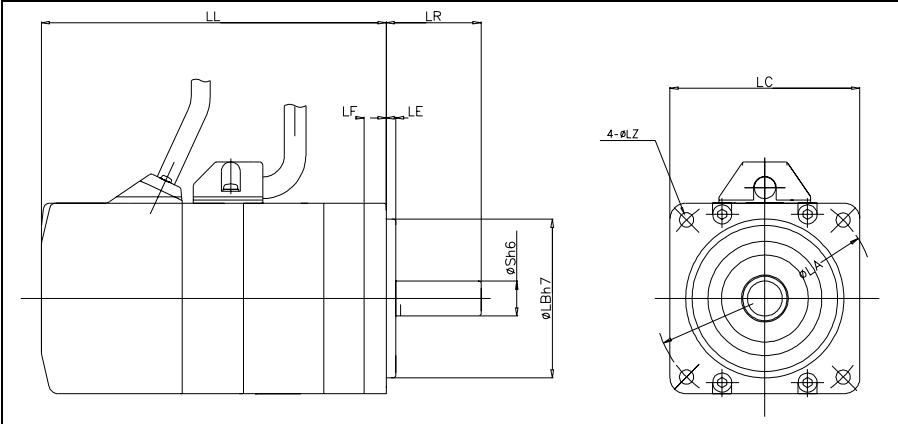

	L1	L2	H1	H2	H3
CSMW-01B	14	12.5	6.2	3	3
CSMW-02B	20	18	8.5	4.	4
CSMW-04B	25	22.5	11	5	5

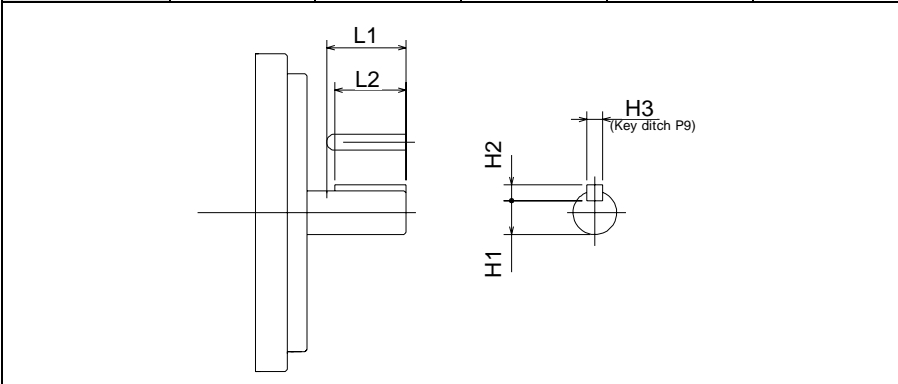

A.4.8 CSMD/F/H/K/S

1. CSMD/H/K/S

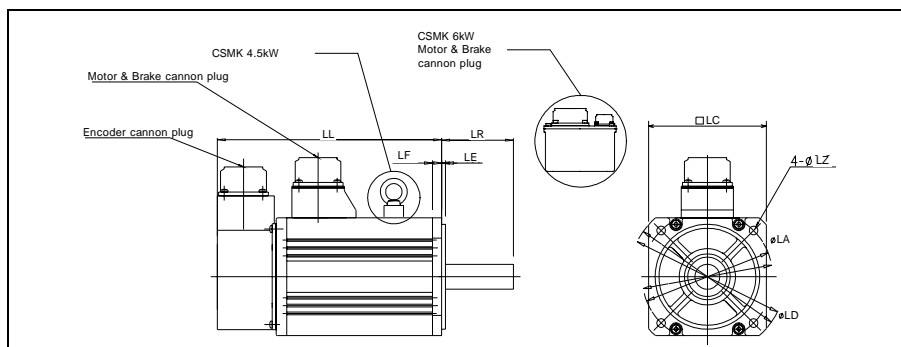

	LL				LR	LA	LC	LD	LE	LF	LZ
	BRAKE 有		BRAKE 無								
	Abs.	Inc.	Abs.	Inc.							
CSMD - 08B	198	169	173	144	55	130 145	120	162	3	10	9
CSMD - 10B	201	172	176	147	55	145	130	165	6	12	9
CSMD - 15B	226	197	201	172	55	145	130	165	6	12	9
CSMD - 20B	251	222	226	197	55	145	130	165	6	12	9
CSMD - 25B	276	247	251	222	65	145	130	165	6	12	9
CSMD - 30B	301	272	276	247	65	145	130	165	6	12	9
CSMD - 35B	283	254	258	229	65	165	150	190	3.2	18	11
CSMD - 40B	303	274	278	249	65	165	150	190	3.2	18	11
CSMD - 45B	256	227	231	202	70	200	180	233	3.2	18	13.5
CSMD - 50B	276	247	251	222	70	200	180	233	3.2	18	13.5
CSMH - 05B	201	172	176	147	70	145	130	165	6	12	9
CSMH - 01B	226	197	201	172	70	145	130	165	6	12	9
CSMH - 15B	251	222	226	197	70	145	130	165	6	12	9
CSMH - 20B	241	212	231	187	80	200	180	233	3.2	18	13.5
CSMH - 30B	256	227	231	202	80	200	180	233	3.2	18	13.5
CSMH - 40B	281	252	256	227	80	200	180	233	3.2	18	13.5
CSMH - 50B	306	277	281	252	80	200	180	233	3.2	18	13.5
CSMK - 03B		158		133	70	145	130	165	6	12	9

CSMK - 06B		183		158	70	145	130	165	6	12	9
CSMK - 09B		208		183	70	145	130	165	6	12	9
CSMK - 12B		195		170	80	200	176	233	3.2	18	13.5
CSMK - 20B		162		190	80	200	176	233	3.2	18	13.5
CSMK - 30B		208		230	80	200	176	233	3.2	18	13.5
CSMK - 45B		353.5		308.5	113	200	176	233	3.2	24	13.5
CSMK - 60B		393.5		348.5	113	200	176	233	3.2	24	13.5
CSMS - 10B	226	197	201	172	55	100	90	120	3	7	6.6
CSMS - 15B	231	202	206	177	55	115	100	135	3	10	9
CSMS - 20B	256	227	231	202	55	115	100	135	3	10	9
CSMS - 25B	281	252	256	227	55	115	100	135	3	10	9
CSMS - 30B	268	239	243	214	55	130 145	120	162	3	10	9
CSMS - 35B	288	259	263	234	55	130 145	120	162	3	10	9
CSMS - 40B	291	262	266	237	65	145	130	165	6	12	9
CSMS - 45B	311	282	286	257	65	145	130	165	6	12	9
CSMS - 50B	331	302	306	277	65	145	130	164	6	12	9

2. CSMF

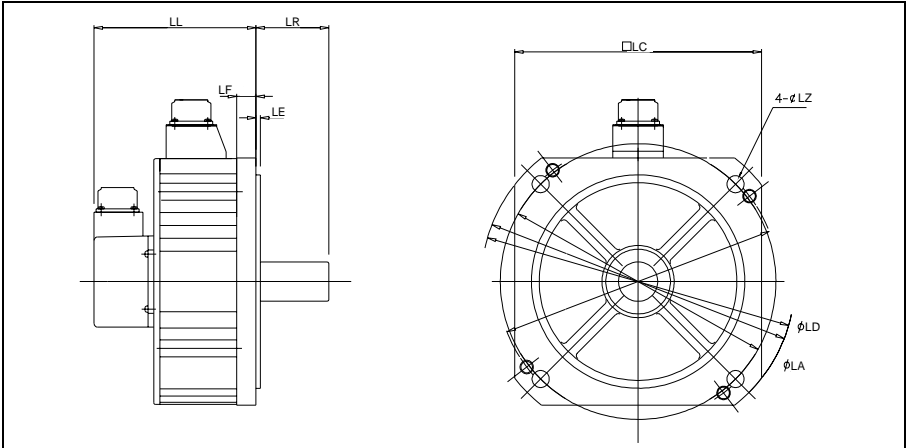

	LL				LR	LA	LC	LD	LE	LF	LZ
	BRAKE 有		BRAKE 無								
	Abs.	Inc.	Abs.	Inc.							
CSMF - 04B	171	142	146	117	55	145	130	165	6	12	9
CSMF - 08B	176	147	151	122	55	200	180	233	3.2	18	13.5
CSMF - 15B	196	167	171	142	65	200	180	233	3.2	18	13.5
CSMF - 25B	192	163	165	136	65	235	220	268	4	16	13.5
CSMF - 35B	200	171	173	144	65	235	220	268	4	16	13.5
CSMF - 45B	220	191	189	160	70	235	220	268	4	16	13.5

3.

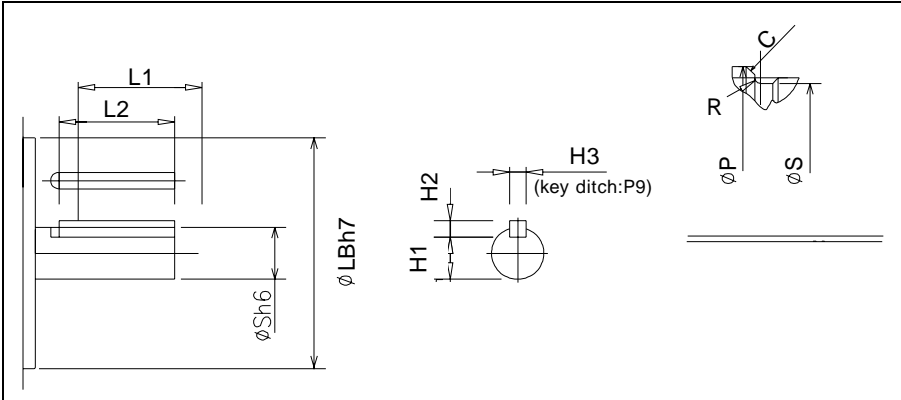

	L1	L2	S	LB	H1	H2	H3	C	R	P
CSMS - 10	45	42	19	80	15.5	6	6	0.3	0.6~ 1.1	19.8
CSMS - 15~25				95						
CSMD - 10~20 CSMH - 05~15 CSMS - 30~35	55	41	22	110	18	7	8	0.5		24
CSMD - 25~30 CSMS - 40~50					20					
CSMD - 08 CSMF - 04					45	42	19			15.5
CSMF - 08	55	41	22	114.3	18	7	8	2.5		39.8
CSMD - 45~50 CSMF - 15 CSMH - 20~50		50	35		30	8	10	0.5		
CSMF - 25~45		50		200				1.5~ 2.5		
CSMD - 35~40		51	28	130	24	7	8	0.5		

A.5

A.5		300
A.5.1	3	300
A.5.2		303
A.5.3 I/O		308
A.5.4		309
A.5.5		309
A.5.6		310

A.5

A.5.1 3

1. (CSM, CSME/Q/R/T/W/Z)

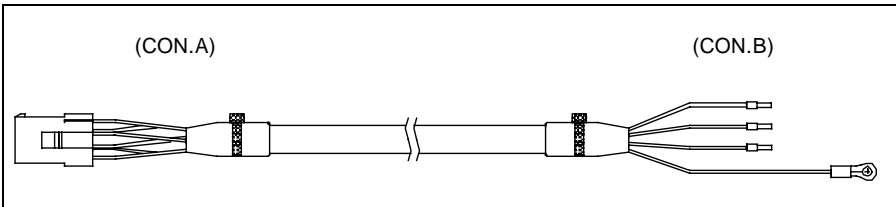

CON.A	CON.B	COLOR	REMARK
1	U	3	1
2	V	3	2
3	W	3	3
4	FG	FG Wire	4(3)

2. (CSMD/F/H/K/S)

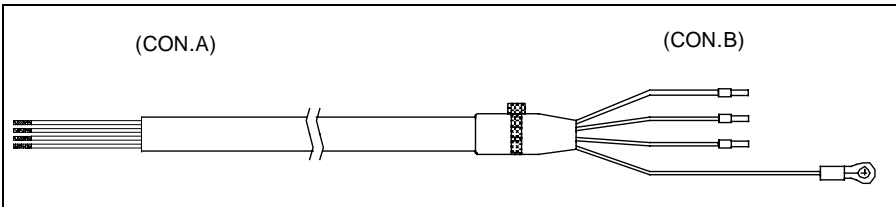

MARKING	COLOR	REMARK
U	3	
V	3	
W	3	
FG	FG Wire	3

3.

CANNON PLUG

MS3102A 20-18P		MS3102A 20-4P									
MOTOR	BRAKE										
CSMD-08~25 CSMH-05~15	有		G	H	A	F	I	B	E	D	C
			BR	BR		U	V	W	FG	FG	
CSMK-03~09 CSMS-10~25	無		A	B	C	D					
			U	V	W	FG					

MS3102A 24-11P		MS3102A 22-22P									
MOTOR	BRAKE										
CSMD-30~50 CSMH-20~50	有		A	B	C	D	E	F	G	H	I
			BR	BR		U	V	W	FG	FG	
CSMS-30~50	無		A	B	C	D					
			U	V	W	FG					

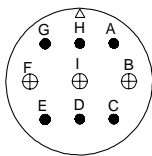

MS3102A 20-18P

MOTOR	BRAKE										
CSMF-04~15	有		G	H	A	F	I	B	E	D	C
			BR	BR		U	V	W	FG	FG	
	無		G	H	A	F	I	B	E	D	C
						U	V	W	FG	FG	

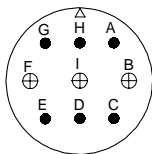

MS3102A 24-11P

MOTOR	BRAKE										
CSMF-20~45 CSMK-12~45	有		A	B	C	D	E	F	G	H	I
			BR	BR		U	V	W	FG	FG	
CSMF-20~45	無		A	B	C	D	E	F	G	H	I
						U	V	W	FG	FG	

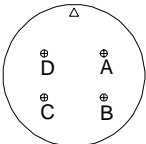
											
MS3102A 22 - 22P											
MOTOR	BRAKE										
CSMK - 12~45	無		A	B	C	D					
			U	V	W	FG					

A.5.2

1. (CSM, CSME/Q/R/T/W/Z)

(CON.A)

(CON.B)

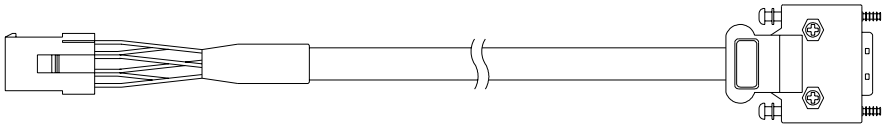

▶ INC.

9 INC : CSM							
CON.A	CON.B			CON.A	CON.B		
1	3	1P(/)-	A	6	8	3P(/)-	/C
2	4	1P(/)-	/A	7	20	4P(/)-	VCC
3	5	2P(/)-	B	8	1	4P(/)-	GND
4	6	2P(/)-	/B	9	12/SH	Shield	FG
5	7	3P(/)-	C				

11 INC : CSMQ, CSMZ							
CON.A	CON.B			CON.A	CON.B		
1	3	1P(/)-	A	7			
2	4	1P(/)-	/A	8	10	5P(/)-	RX
3	5	2P(/)-	B	9	13	5P(/)-	/RX
4	6	2P(/)-	/B	10	20	4P(/)-	VCC
5	7	3P(/)-	C	11	1	4P(/)-	GND
6	8	3P(/)-	/C	12	12	Shield	FG

15 INC : CSM							
CON.A	CON.B			CON.A	CON.B		
1	3	1P(/)-	A	9	14	6P(/)-	V
2	4	1P(/)-	/A	10	15	6P(/)-	/V
3	5	2P(/)-	B	11	16	7P(/)-	W
4	6	2P(/)-	/B	12	17	7P(/)-	/W
5	7	3P(/)-	C	13	20	4P(/)-	VCC
6	8	3P(/)-	/C	14	1	4P(/)-	GND
7	10	5P(/)-	U	15	12	Shield	FG
8	13	5P(/)-	/U				

► ABS.

15 ABS : CSM							
CON.A	CON.B			CON.A	CON.B		
1	3	1P(/)-	A	9	11	6P(/)-	RST
2	4	1P(/)-	/A	10	12	Shield	FG
3	5	2P(/)-	B	11	18	7P(/)-	BAT+
4	6	2P(/)-	/B	12	19	7P(/)-	BAT-
5	7	3P(/)-	C	13	20	4P(/)-	VCC
6	8	3P(/)-	/C	14	1	4P(/)-	GND
7	10	5P(/)-	RX	15	12	Shield	FG
8	13	5P(/)-	/RX				

15 ABS : CSMQ, CSMZ							
CON.A	CON.B			CON.A	CON.B		
1	3	1P(/)-	A	9	11	6P(/)-	RST
2	4	1P(/)-	/A	10	12	Shield	FG
3	5	2P(/)-	B	11	10	7P(/)-	RX
4	6	2P(/)-	/B	12	13	7P(/)-	/RX
5	7	3P(/)-	C	13	20	4P(/)-	VCC
6	8	3P(/)-	/C	14	1	4P(/)-	GND
7	18	5P(/)-	BAT+	15	12	Shield	FG
8	19	5P(/)-	BAT-				



CSME/R/T/W							
CON.A	CON.B			CON.A	CON.B		
1	18	1P(/)-	BAT+	6			N.C
2	19	1P(/)-	BAT-	7	20	4P(/)-	VCC
3	SH	Shield	FG	8	1	4P(/)-	GND
4	10	2P(/)-	SD+	9			N.C
5	13	3P(/)-	SD-				

2. (CSMD/F/H/K/S)

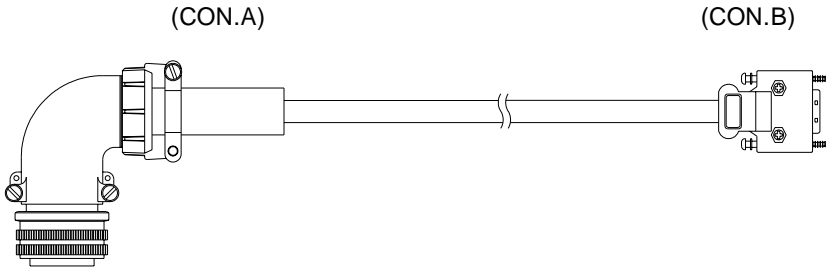

▶ INC.

11 INC :							
CON.A	CON.B			CON.A	CON.B		
A	3	1P(/)-	A	G	1	4P(/)-	GND
B	4	1P(/)-	/A	H	20	4P(/)-	VCC
C	5	2P(/)-	B	J	12/SH	Shield	FG
D	6	2P(/)-	/B	P	10	5P(/)-	RX
E	7	3P(/)-	C	R	13	5P(/)-	/RX
F	8	3P(/)-	/C				

15 INC :							
CON.A	CON.B			CON.A	CON.B		
A	3	1P(/)-	A	J	12/SH	Shield	FG
B	4	1P(/)-	/A	K	10	5P(/)-	U
C	5	2P(/)-	B	L	13	5P(/)-	/U
D	6	2P(/)-	/B	M	14	6P(/)-	V
E	7	3P(/)-	C	N	15	6P(/)-	/V
F	8	3P(/)-	/C	P	16	7P(/)-	W
G	1	4P(/)-	GND	R	17	7P(/)-	/W
H	20	4P(/)-	VCC				

► ABS.

15 ABS :							
CON.A	CON.B			CON.A	CON.B		
A	3	1P(/)-	A	J	12/SH	Shield	FG
B	4	1P(/)-	/A	K	10	5P(/)-	RX
C	5	2P(/)-	B	L	13	5P(/)-	/RX
D	6	2P(/)-	/B	R	11	6P(/)-	RST
E	7	3P(/)-	C		15		N.C
F	8	3P(/)-	/C	S	19	7P(/)-	BAT-
G	1	4P(/)-	GND	T	18	7P(/)-	BAT+
H	20	4P(/)-	VCC				

3.

CANNON PLUG

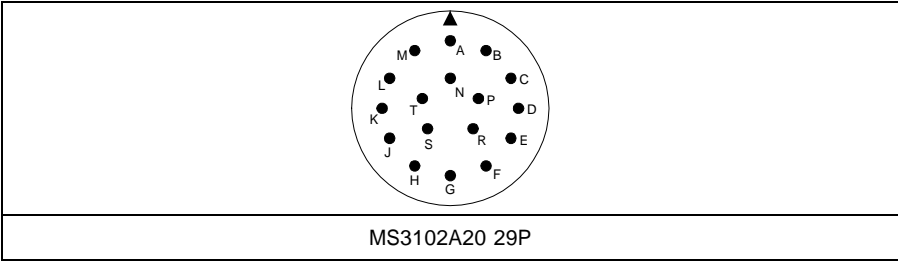

A.5.3 I/O

CON.A

(CON.B)

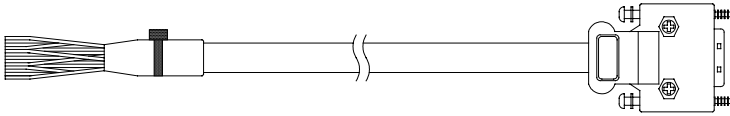

CON.B		CON.B		CON.B		CON.B	
1		14	/1	27	/3	40	/
2		15	/2	28	/3	41	/
3		16	/2	29	/4	42	/
4		17	/2	30	/4	43	/1
5		18	/2	31	/4	44	/1
6		19	/2	32	/4	45	/1
7		20	/2	33	/4	46	/1
8	/1	21	/2	34	/4	47	/1
9	/1	22	/3	35	/4	48	/1
10	/1	23	/3	36	/	49	/1
11	/1	24	/3	37	/	50	Shield()
12	/1	25	/3	38	/		
13	/1	26	/3	39	/		

A.5.4

1. (CSM, CSME/Q/R/T/W/Z)

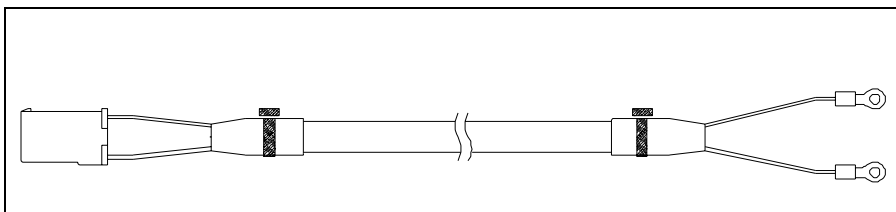

2. (CSMD/F/H/K/S)

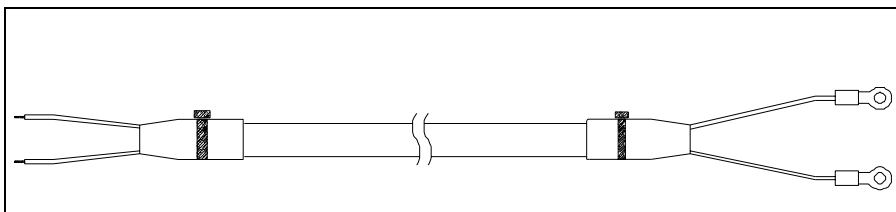

MARKING	COLOR
BK+	2
BK-	2

A.5.5

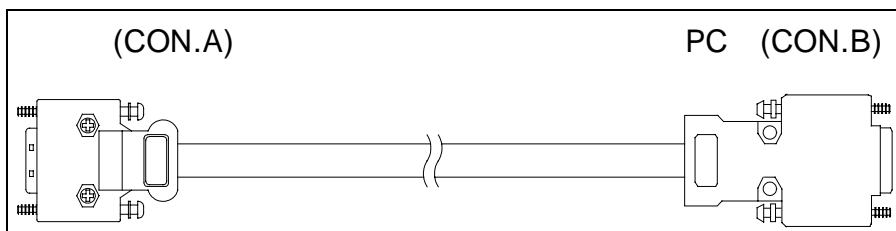

CON.A	CON.B			CON.A	CON.B		
11	2	1P(/)-	RX	1	5	3P(/)-	GND
12	3	2P(/)-	TX	9	N.C		FG

A.5.6

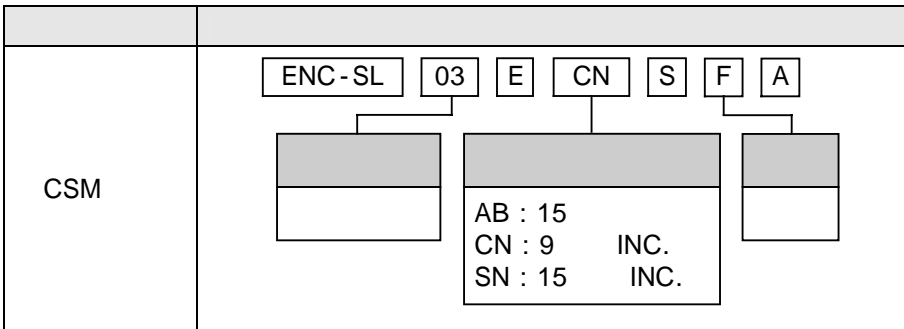
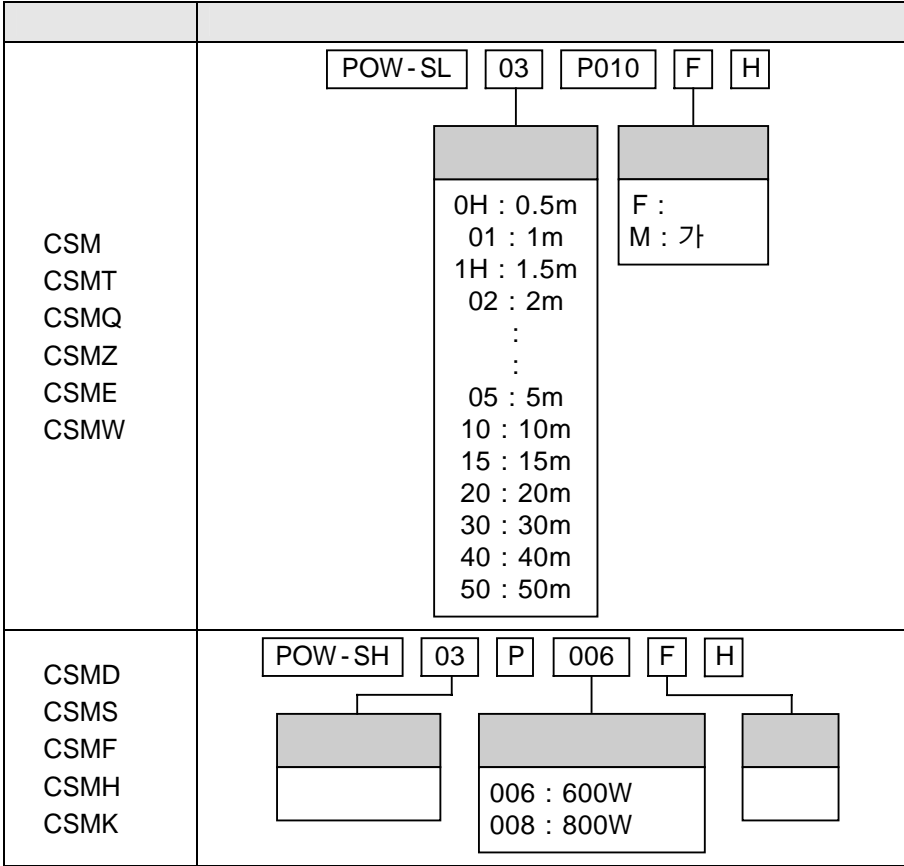

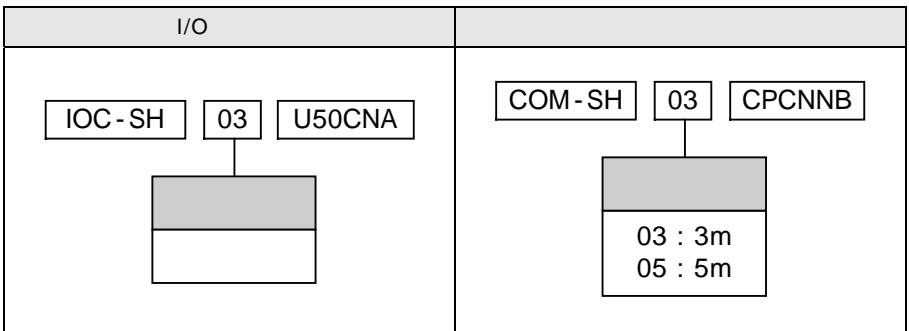
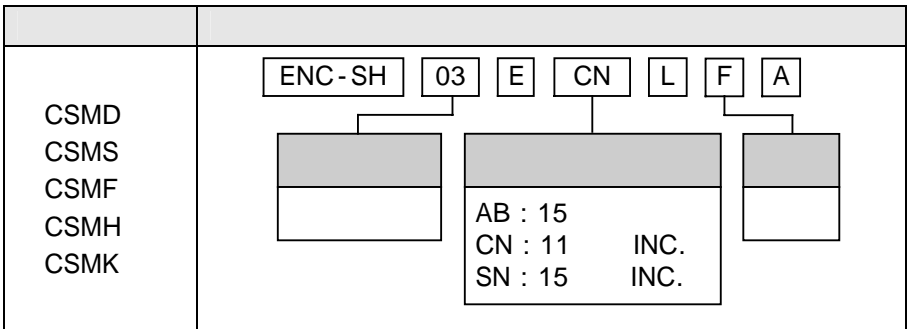
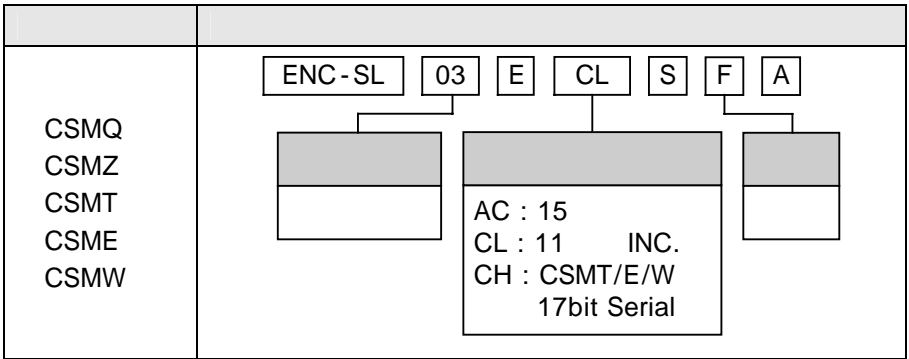

50PIN I/O	20PIN
CON - SCONN50PIN	CON - SCONN20PEN

부 록 A.6 부하 계산

A.6 부하 계산.....	313
A.6.1 ROLL 부하.....	313
A.6.2 TIMING BELT 부하.....	316
A.6.3 수평 BALL SCREW 부하.....	318
A.6.4 수직 BALL SCREW 부하.....	320
A.6.5 RACK & PINION 부하.....	322
A.6.6 원판 부하.....	324

A.6 부하 계산

■ 부하 시스템의 운전 속도 선도

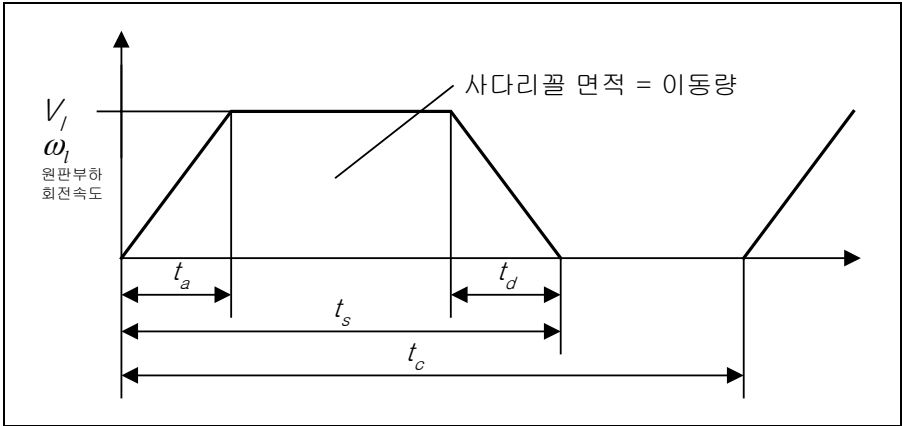

위 운전 속도 선도를 참고한 시스템의 부하 계산법은 다음과 같습니다.

A.6.1 ROLL 부하

<p>기계구성</p>	
	<p>F : tension[N] P : Pressure V_l : 부하속도[m/min] D : Roll 직경[m] $1/R$: 감속비 μ : 마찰계수 η : 기계효율</p>
<p>이동량[m]</p>	$L_s = \frac{V_l}{60} \times \frac{2t_s - t_a - t_d}{2}$ <p>if $t_a = t_d$, $L_s = \frac{V_l}{60} \times (t_s - t_a)$</p>

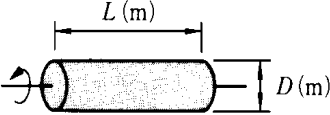
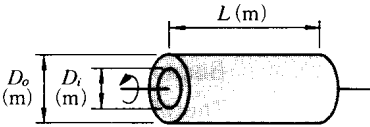
모터축 회전속도 [r/min]		$N_M = \frac{RV_l}{\pi D}$
부하토크 [N·m]		$T_L = \frac{(\mu P + F)D}{2R\eta}$
부하 관성모멘트 [kg·m ²]		$J_L = J_G + \frac{J_R}{R^2}$ <p>J_R: Roll 관성, J_G: 기어, 커플링 관성</p>
J_R	Solid Cylinder	 $J_R = \frac{MD^2}{8} = \frac{\pi\rho LD^4}{32}$ <p>M: 질량 [kg], ρ: 밀도 [kg/m³] $\rho = 7.87 \times 10^3$ [kg/m³]; 철 $\rho = 2.70 \times 10^3$ [kg/m³]; 알루미늄</p>
	Hollow Cylinder	 $J_R = \frac{M(D_o^2 - D_i^2)}{8} = \frac{\pi\rho L(D_o^4 - D_i^4)}{32}$
최소가속시간 [s]		$t_{am} = \frac{2\pi N_M (J_M + J_L)}{60(T_{PM} - T_L)}$ <p>J_M: 모터 관성, T_{PM}: 모터 최대토크</p>

최소감속시간[s]	$t_{dm} = \frac{2\pi N_M (J_M + J_L)}{60(T_{PM} + T_L)}$
부하 주행 power[W]	$P_o = \frac{2\pi N_M T_L}{60}$
부하 가속 power[W]	$P_a = \left(\frac{2\pi N_M}{60}\right)^2 \times \frac{J_L}{t_a}, (t_a \leq t_{am})$
소요가속토크[N·m]	$T_p = \frac{2\pi N_M (J_M + J_L)}{60t_a} + T_L, (t_a \leq t_{am})$
소요감속토크[N·m]	$T_s = \frac{2\pi N_M (J_M + J_L)}{60t_d} - T_L, (t_a \leq t_{dm})$
토크 실효치 [[N·m]	$T_{rms} = \sqrt{\frac{T_p^2 t_a + T_L^2 (t_s - t_a - t_d) + T_s^2 t_d}{t_s}}$

A.6.2 TIMING BELT 부하

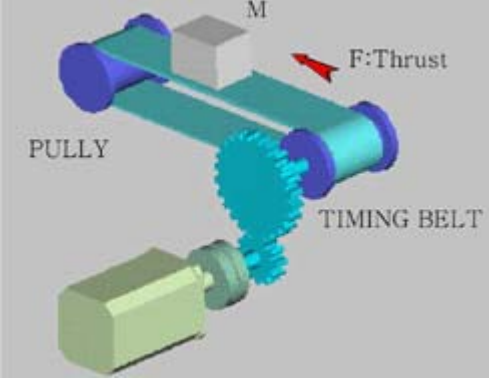
<p>기계구성</p>	 <p>M : 직선운동부분 부하질량 [kg] F : 추력 [N] V_l : 부하속도 [m/min] D : 풀리 직경 [m] $1/R$: 감속비 μ : 마찰계수 η : 기계효율</p>
<p>이동량 [m]</p>	$L_s = \frac{V_l}{60} \times \frac{2t_s - t_a - t_d}{2}$ <p>if $t_a = t_d$, $L_s = \frac{V_l}{60} \times (t_s - t_a)$</p>
<p>모터축 회전속도 [r/min]</p>	$N_M = \frac{RV_l}{\pi D}$
<p>부하토크 [N·m]</p>	$T_L = \frac{(9.8\mu M + F)D}{2R\eta}$
<p>부하 관성모멘트 [kg·m²]</p>	$J_L = J_W + J_G + \frac{J_P}{R^2}$ <p>J_W : 직선운동부분 부하관성, J_P : 풀리부 관성 J_G : 기어, 커플링 관성</p> $J_W = M\left(\frac{D}{2R}\right)^2$

최소가속시간[s]	$t_{am} = \frac{2\pi N_M (J_M + J_L)}{60(T_{PM} - T_L)}$ $J_M : \text{모터 관성}, T_{PM} : \text{모터 최대토크}$
최소감속시간[s]	$t_{dm} = \frac{2\pi N_M (J_M + J_L)}{60(T_{PM} + T_L)}$
부하 주행 power[W]	$P_o = \frac{2\pi N_M T_L}{60}$
부하 가속 power[W]	$P_a = \left(\frac{2\pi N_M}{60}\right)^2 \times \frac{J_L}{t_a}, (t_a \leq t_{am})$
소요가속토크[N·m]	$T_p = \frac{2\pi N_M (J_M + J_L)}{60t_a} + T_L, (t_a \leq t_{am})$
소요감속토크[N·m]	$T_s = \frac{2\pi N_M (J_M + J_L)}{60t_d} - T_L, (t_a \leq t_{dm})$
토크 실효치[[N·m]	$T_{rms} = \sqrt{\frac{T_p^2 t_a + T_L^2 (t_s - t_a - t_d) + T_s^2 t_d}{t_s}}$

A.6.3 수평 BALL SCREW 부하

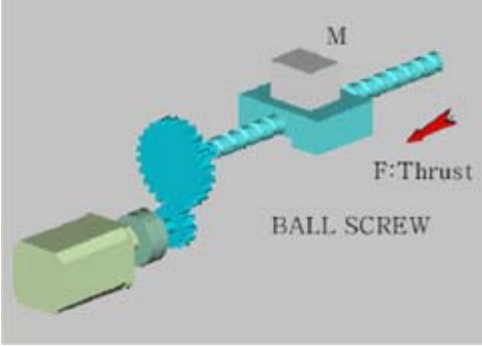
<p>기계구성</p>	 <p>M : 직선운동부분 부하질량[kg] F : 추력[N] V_l : 부하속도[m/min] D_B : Ball Screw 직경[m] P_B : Ball Screw Lead[m] $1/R$: 감속비 L_B : Ball Screw 길이[m] μ : 마찰계수 η : 기계효율</p>
<p>이동량[m]</p>	$L_s = \frac{V_l}{60} \times \frac{2t_s - t_a - t_d}{2}$ <p>if $t_a = t_d$, $L_s = \frac{V_l}{60} \times (t_s - t_a)$</p>
<p>모터축 회전속도[r/min]</p>	$N_M = \frac{RV_l}{P_B}$
<p>부하토크[N·m]</p>	$T_L = \frac{(9.8\mu M + F)P_B}{2\pi R\eta}$

<p>부하 관성모멘트 [kg·m²]</p>	$J_L = J_W + J_G + \frac{J_B}{R^2}$ <p>J_W: 직선운동부분 부하관성, J_B: Ball Screw 관성 J_G: 기어, 커플링 관성</p> $J_W = M \left(\frac{P_B}{2\pi R} \right)^2, \quad J_B = \frac{M_B D_B^2}{8} = \frac{\pi \rho L_B D_B^4}{32}$ <p>M_B: Ball Screw 질량 [kg] $\rho = 7.87 \times 10^3$ [kg/m³]; 철 $\rho = 2.70 \times 10^3$ [kg/m³]; 알루미늄</p>
<p>최소가속시간 [s]</p>	$t_{am} = \frac{2\pi N_M (J_M + J_L)}{60(T_{PM} - T_L)}$ <p>J_M: 모터 관성, T_{PM}: 모터최대토크</p>
<p>최소감속시간 [s]</p>	$t_{dm} = \frac{2\pi N_M (J_M + J_L)}{60(T_{PM} + T_L)}$
<p>부하 주행 power [W]</p>	$P_o = \frac{2\pi N_M T_L}{60}$
<p>부하 가속 power [W]</p>	$P_a = \left(\frac{2\pi N_M}{60} \right)^2 \times \frac{J_L}{t_a}, \quad (t_a \leq t_{am})$
<p>소요가속토크 [N·m]</p>	$T_p = \frac{2\pi N_M (J_M + J_L)}{60t_a} + T_L, \quad (t_a \leq t_{am})$
<p>소요감속토크 [N·m]</p>	$T_s = \frac{2\pi N_M (J_M + J_L)}{60t_d} - T_L, \quad (t_a \leq t_{dm})$
<p>토크 실효치 [[N·m]</p>	$T_{rms} = \sqrt{\frac{T_p^2 t_a + T_L^2 (t_s - t_a - t_d) + T_s^2 t_d}{t_s}}$

A.6.4 수직 BALL SCREW 부하

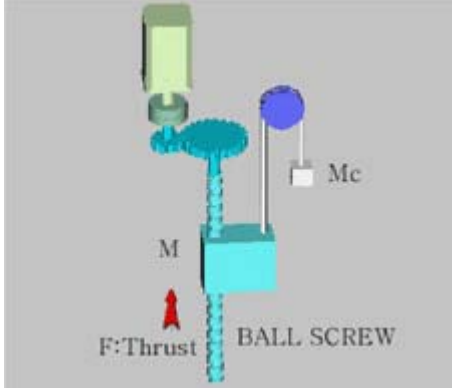
<p>기계구성</p>	 <p>M : 직선운동부분 부하질량[kg] F : 추력[N] V_l : 부하속도[m/min] D_B : Ball Screw 직경[m] P_B : Ball Screw Lead[m] $1/R$: 감속비 L_B : Ball Screw 길이[m] μ : 마찰계수 η : 기계효율 M_C : Counter 부 질량[kg]</p>
<p>이동량[m]</p>	$L_s = \frac{V_l}{60} \times \frac{2t_s - t_a - t_d}{2}$ <p>if $t_a = t_d$, $L_s = \frac{V_l}{60} \times (t_s - t_a)$</p>
<p>모터축 회전속도[r/min]</p>	$N_M = \frac{RV_l}{P_B}$
<p>부하토크[N·m]</p>	$T_L = \frac{\{9.8\mu(M - M_C) + F\}P_B}{2\pi R \eta}$

<p>부하 관성모멘트 [kg·m²]</p>	$J_L = J_W + J_G + \frac{J_B}{R^2}$ <p>J_W: 직선운동부분 부하관성, J_B: Ball Screw 관성 J_G: 기어, 커플링 관성</p> $J_W = (M + M_C) \left(\frac{P_B}{2\pi R} \right)^2$ $J_B = \frac{M_B D_B^2}{8} = \frac{\pi \rho L_B D_B^4}{32}$ <p>M_B: Ball Screw 질량 [kg] $\rho = 7.87 \times 10^3$ [kg/m³] ; 철 $\rho = 2.70 \times 10^3$ [kg/m³] ; 알루미늄</p>
<p>최소가속시간 [s]</p>	$t_{am} = \frac{2\pi N_M (J_M + J_L)}{60(T_{PM} - T_L)}$ <p>J_M: 모터 관성, T_{PM}: 모터최대토크</p>
<p>최소감속시간 [s]</p>	$t_{dm} = \frac{2\pi N_M (J_M + J_L)}{60(T_{PM} + T_L)}$
<p>부하 주행 power [W]</p>	$P_o = \frac{2\pi N_M T_L}{60}$
<p>부하 가속 power [W]</p>	$P_a = \left(\frac{2\pi N_M}{60} \right)^2 \times \frac{J_L}{t_a}, \quad (t_a \leq t_{am})$
<p>소요가속토크 [N·m]</p>	$T_p = \frac{2\pi N_M (J_M + J_L)}{60t_a} + T_L, \quad (t_a \leq t_{am})$
<p>소요감속토크 [N·m]</p>	$T_s = \frac{2\pi N_M (J_M + J_L)}{60t_d} - T_L, \quad (t_a \leq t_{dm})$
<p>토크 실효치 [[N·m]</p>	$T_{rms} = \sqrt{\frac{T_p^2 t_a + T_L^2 (t_s - t_a - t_d) + T_s^2 t_d}{t_s}}$

A.6.5 RACK & PINION 부하

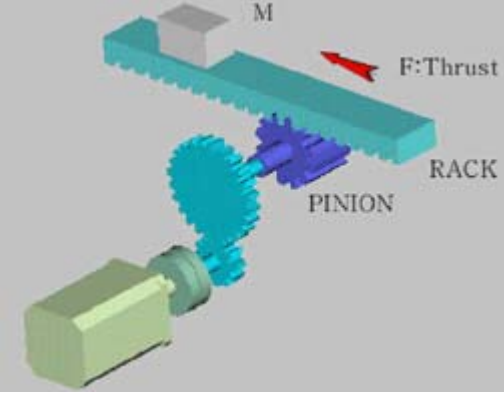
<p>기계구성</p>	 <p>M : 직선운동부분 부하질량 [kg] F : 추력 [N] V_l : 부하속도 [m/min] D : Pinion 직경 [m] $1/R$: 감속비 t : Pinion 두께 [m] η : 기계효율 μ : 마찰계수</p>
<p>이동량 [m]</p>	$L_s = \frac{V_l}{60} \times \frac{2t_s - t_a - t_d}{2}$ <p>if $t_a = t_d$, $L_s = \frac{V_l}{60} \times (t_s - t_a)$</p>
<p>모터축 회전속도 [r/min]</p>	$N_M = \frac{RV_l}{P_B}$
<p>부하토크 [N·m]</p>	$T_L = \frac{(9.8\mu M + F)D}{2R\eta}$

<p>부하 관성모멘트 [kg·m²]</p>	$J_L = J_W + J_G + \frac{J_P}{R^2}$ <p>J_W: 직선운동부분 부하관성, J_P: Pinion 관성 J_G: 기어, 커플링 관성</p> $J_W = M \left(\frac{D}{2R} \right)^2, \quad J_P = \frac{M_P D^2}{8} = \frac{\pi \rho t D^4}{32}$ <p>M_P: Pinion 질량 [kg] $\rho = 7.87 \times 10^3$ [kg/m³]; 철 $\rho = 2.70 \times 10^3$ [kg/m³]; 알루미늄</p>
<p>최소가속시간 [s]</p>	$t_{am} = \frac{2\pi N_M (J_M + J_L)}{60(T_{PM} - T_L)}$ <p>J_M: 모터 관성, T_{PM}: 모터최대토크</p>
<p>최소감속시간 [s]</p>	$t_{dm} = \frac{2\pi N_M (J_M + J_L)}{60(T_{PM} + T_L)}$
<p>부하 주행 power [W]</p>	$P_o = \frac{2\pi N_M T_L}{60}$
<p>부하 가속 power [W]</p>	$P_a = \left(\frac{2\pi N_M}{60} \right)^2 \times \frac{J_L}{t_a}, \quad (t_a \leq t_{am})$
<p>소요가속토크 [N·m]</p>	$T_p = \frac{2\pi N_M (J_M + J_L)}{60t_a} + T_L, \quad (t_a \leq t_{am})$
<p>소요감속토크 [N·m]</p>	$T_s = \frac{2\pi N_M (J_M + J_L)}{60t_d} - T_L, \quad (t_a \leq t_{dm})$
<p>토크 실효치 [[N·m]</p>	$T_{rms} = \sqrt{\frac{T_p^2 t_a + T_L^2 (t_s - t_a - t_d) + T_s^2 t_d}{t_s}}$

A.6.6 원판 부하

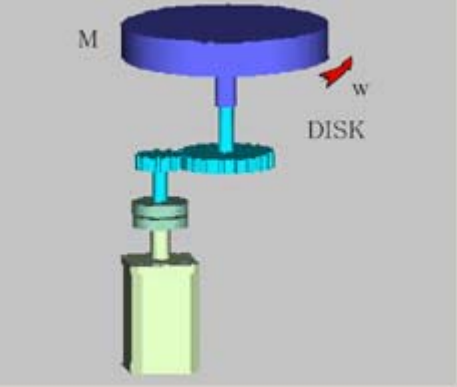
<p>기계구성</p>	
	<p> M : 원판부하질량 [kg] T_l : 부하 토크 ω_l : 원판부하 회전속도 [rpm] D : 원판부하 직경 [m] $1/R$: 감속비 η : 기계효율 t : 원판부하 두께 [m] </p>
<p>이동량 [rad]</p>	$\theta_s = \frac{\omega_l}{60} \times \frac{2t_s - t_a - t_d}{2}$ <p>if $t_a = t_d$, $\theta_s = \frac{\omega_l}{60} \times (t_s - t_a)$</p>
<p>모터축 회전속도 [r/min]</p>	$N_M = R\omega_l$
<p>부하토크 [N·m]</p>	$T_L = \frac{T_l}{R}$

<p>부하 관성모멘트 [kg·m²]</p>	$J_L = J_G + \frac{J_W}{R^2}$ <p>J_W: 원판부하 관성, J_G: 기어, 커플링 관성</p> $J_R = \frac{MD^2}{8} = \frac{\pi\rho tD^4}{32}$ <p>$\rho = 7.87 \times 10^3$ [kg/m³] ; 철 $\rho = 2.70 \times 10^3$ [kg/m³] ; 알루미늄</p>
<p>최소가속시간 [s]</p>	$t_{am} = \frac{2\pi N_M (J_M + J_L)}{60(T_{PM} - T_L)}$ <p>J_M: 모터 관성, T_{PM}: 모터최대토크</p>
<p>최소감속시간 [s]</p>	$t_{dm} = \frac{2\pi N_M (J_M + J_L)}{60(T_{PM} + T_L)}$
<p>부하 주행 power[W]</p>	$P_o = \frac{2\pi N_M T_L}{60}$
<p>부하 가속 power[W]</p>	$P_a = \left(\frac{2\pi N_M}{60}\right)^2 \times \frac{J_L}{t_a}, (t_a \leq t_{am})$
<p>소요가속토크 [N·m]</p>	$T_p = \frac{2\pi N_M (J_M + J_L)}{60t_a} + T_L, (t_a \leq t_{am})$
<p>소요감속토크 [N·m]</p>	$T_s = \frac{2\pi N_M (J_M + J_L)}{60t_d} - T_L, (t_d \leq t_{dm})$
<p>토크 실효치 [[N·m]</p>	$T_{rms} = \sqrt{\frac{T_p^2 t_a + T_L^2 (t_s - t_a - t_d) + T_s^2 t_d}{t_s}}$

부 록 A.7 모터 용량 선정

■ 수평 BALL SCREW 부하 시스템

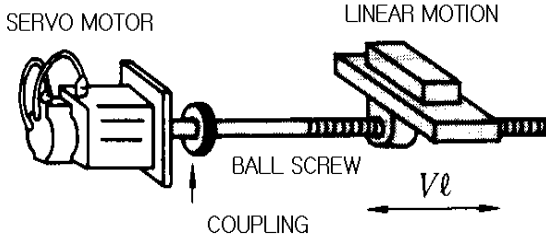

부하 속도 $V_l = 15\text{m/min}$
 직선운동부분 부하질량 $M = 500\text{kg}$
 Ball Screw 길이 $L_B = 1.4\text{m}$
 Ball Screw 직경 $D_B = 0.04\text{m}$
 Ball Screw Lead $P_B = 0.01\text{m}$
 Coupling 질량 $M_C = 1\text{kg}$

Coupling 외경 $D_C = 0.06\text{m}$
 이송 회수 $n = 40/\text{min}$
 이송 거리 $L_s = 0.275\text{m}$
 이송 시간 $t_s = 1.2\text{s}$
 마찰 계수 $\mu = 0.2$
 기계 효율 $\eta = 0.9$

■ 속도 선도

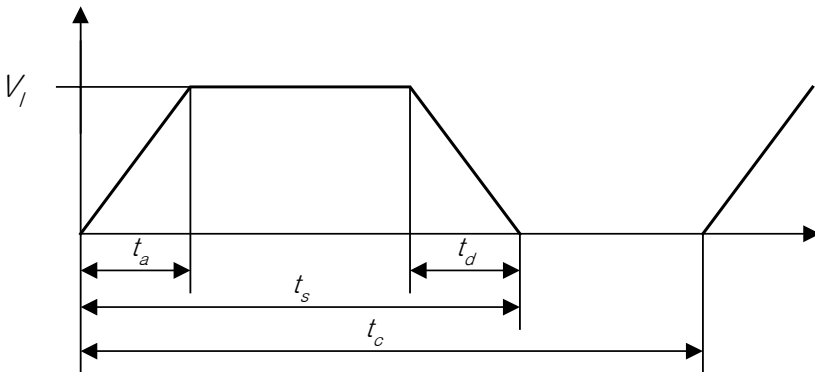

1. 회전 속도

Coupling 직결이므로 $R=1$

$$\text{모터축 회전속도 } N_M = \frac{RV_l}{P_B} = \frac{1 \times 15}{0.01} = 1500 \text{ [r/min]}$$

$$\text{이송회수 } n=40 \text{ 이므로 } t_c = \frac{60}{n} = \frac{60}{40} = 1.5 \text{ [s]}$$

$$t_a = t_s - \frac{60 \times L_s}{V_l} = 1.2 - \frac{60 \times 0.275}{15} = 0.1, \text{ 여기서 } t_a = t_d$$

2. 부하 토크

$$T_L = \frac{(9.8\mu M + F)P_B}{2\pi R \eta} = \frac{9.8 \times 0.2 \times 500 \times 0.01}{2\pi \times 1 \times 0.9} = 1.73 \text{ [N}\cdot\text{m]}$$

3. 부하 관성모멘트

$$\text{직선운동부 } J_W = M \left(\frac{P_B}{2\pi R} \right)^2 = 500 \times \left(\frac{0.01}{2\pi \times 1} \right)^2 = 12.7 \times 10^{-4} \text{ [kg}\cdot\text{m}^2]$$

Ball Screw

$$J_B = \frac{\pi \rho L_B D_B^4}{32} = \frac{\pi}{32} \times 7.87 \times 10^3 \times 1.4 \times 0.04^4 = 27.7 \times 10^{-4} \text{ [kg}\cdot\text{m}^2]$$

Coupling

$$J_G = \frac{1}{8} \times M_c \times D_c^2 = \frac{1}{8} \times 0.06^2 = 4.5 \times 10^{-4} \text{ [kg}\cdot\text{m}^2]$$

$$\text{총 부하 관성모멘트 } J_L = J_W + J_G + \frac{J_B}{R^2} = 44.9 \times 10^{-4} \text{ [kg}\cdot\text{m}^2]$$

4. 부하 주행 power

$$P_o = \frac{2\pi N_M T_L}{60} = \frac{2\pi \times 1500 \times 1.73}{60} = 272 \text{ [W]}$$

5. 부하 가속 power

$$P_a = \left(\frac{2\pi N_M}{60}\right)^2 \times \frac{J_L}{t_a} = \left(\frac{2\pi \times 1500}{60}\right)^2 \times \frac{44.9 \times 10^{-4}}{0.1} = 1108 \text{ [W]}$$

6. 서보 모터의 가선택

서보 모터 선정 시 아래 조건을 만족해야 합니다.

[조건]

$J_L \leq$ 서보 드라이브의 허용 부하 관성모멘트

소요 가속 토크 \leq 모터의 순시 최대 토크

소요 감속 토크 \leq 모터의 순시 최대 토크

토크 실효치 \leq 모터의 정격 토크

$P_o + P_a \leq (1 \sim 2) \times$ 모터의 정격 출력

모터축 회전 속도 $N_M \leq$ 모터의 정격 회전 속도

CSMD 1kW 모터로 가선택, 모터 사양은 다음과 같습니다.

- 정격 출력 : 1kW
- 정격 회전 속도 : 2000RPM
- 정격 토크 : 4.8[N·m]
- 순시 최대 토크 : 14.4[N·m]
- 모터축 관성모멘트 : $6.17 \times 10^{-4} [\text{kg} \cdot \text{m}^2]$
- 서보 드라이브의 허용 부하 관성모멘트 : 모터축 관성모멘트의 10배

7. 모터 선정 Check

가) 관성모멘트 비교

$$J_L = 44.9 \times 10^{-4} [\text{kg} \cdot \text{m}^2] < 61.7 \times 10^{-4} [\text{kg} \cdot \text{m}^2] \quad \text{OK}$$

나) 기동 토크 비교(소요 가속 토크)

$$T_P = \frac{2\pi N_M (J_M + J_L)}{60t_a} + T_L = \frac{2\pi \times 1500 \times (6.17 + 44.9)}{60 \times 0.1} + 1.73$$
$$= 9.75 [\text{N}\cdot\text{m}] < 14.4 [\text{N}\cdot\text{m}] \quad \text{OK}$$

다) 기동 토크 비교(소요 감속 토크)

$$T_S = \frac{2\pi N_M (J_M + J_L)}{60t_a} - T_L = \frac{2\pi \times 1500 \times (6.17 + 44.9)}{60 \times 0.1} - 1.73$$
$$= 6.29 [\text{N}\cdot\text{m}] < 14.4 [\text{N}\cdot\text{m}] \quad \text{OK}$$

라) 토크 실효치

$$T_{rms} = \sqrt{\frac{T_P^2 t_a + T_L^2 (t_s - t_a - t_d) + T_S^2 t_d}{t_c}}$$
$$= \sqrt{\frac{9.75^2 \times 0.1 + 1.73^2 \times 10 + 6.29^2 \times 0.1}{1.5}}$$
$$= 3.31 [\text{N}\cdot\text{m}] < 4.8 [\text{N}\cdot\text{m}] \quad \text{OK}$$

마) Power

$$P_o + P_a = 1108 + 272 = 1380 [\text{W}] < 2 \text{ kW} \quad \text{OK}$$

바) 회전 속도

$$N_M = 1500 \text{ RPM} < 2000 \text{ RPM} \quad \text{OK}$$

8. 서보 모터의 최종 선정

위 선정 조건을 모두 만족함으로, 가선택된 서보 모터를 사용할 수 있습니다. 선정된 서보 모터는 다음과 같은 속도에 따른 토크를 발생합니다.

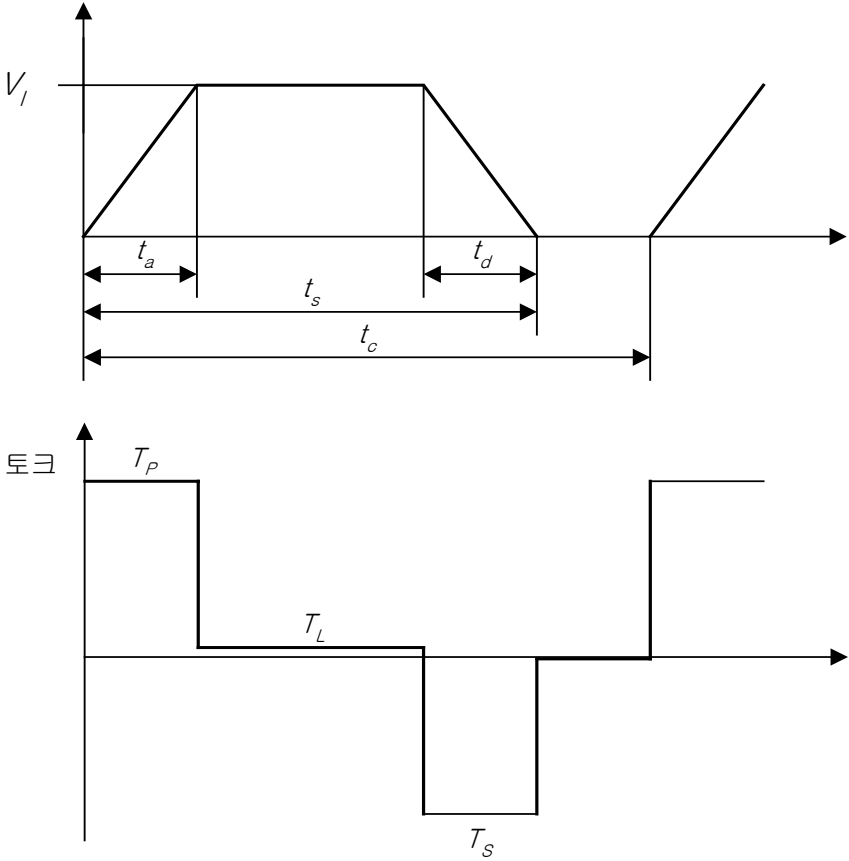

A.8



	Revision No.	
2002.08	1.0	